

8 F

3 L

X A

V

I

B K

1 E

1 R

20
19

FLAVIKER

CONTEMPORARY ECO CERAMICS

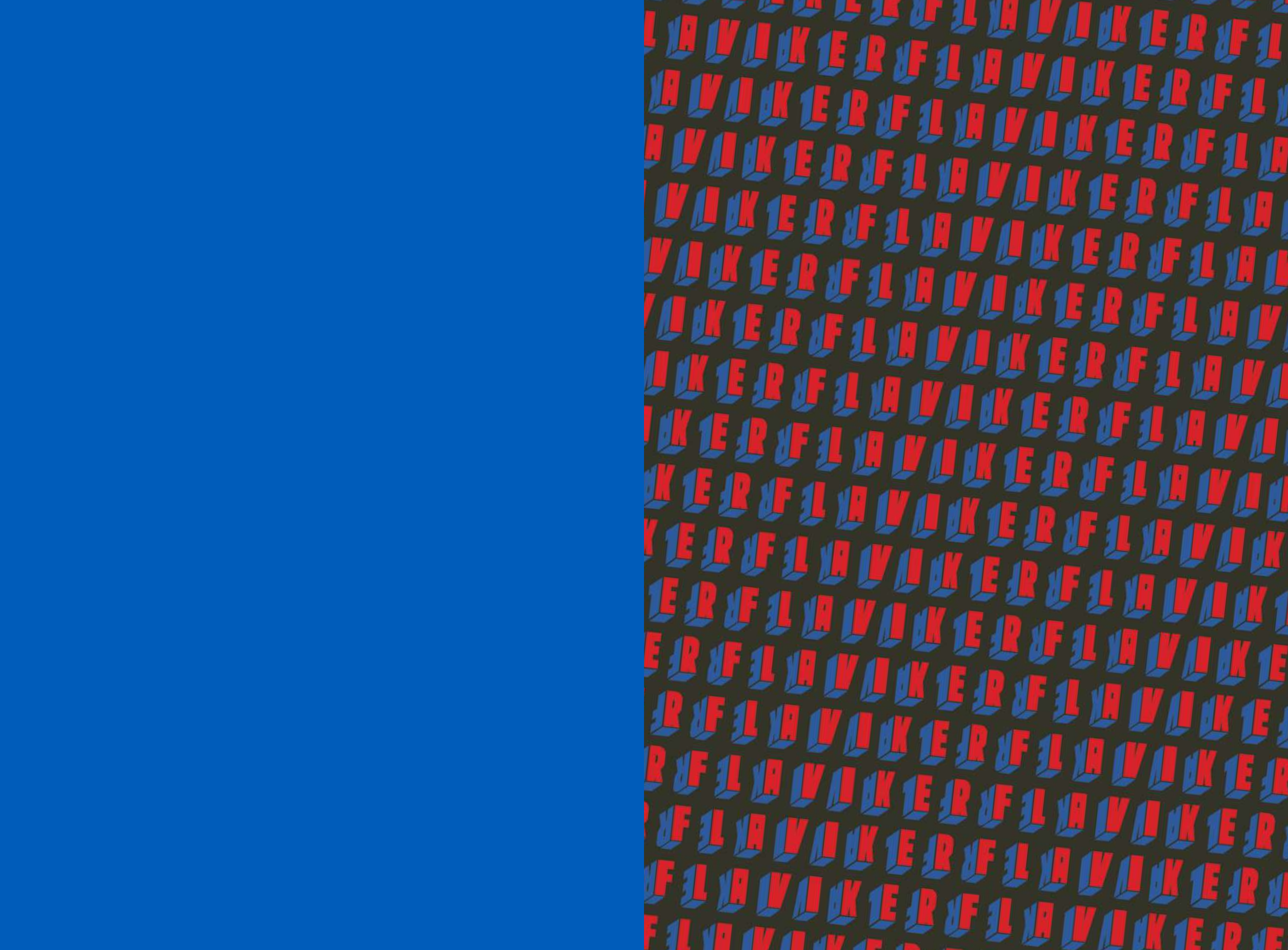

BACK TO 2019

Le superfici ceramiche Flaviker aprono prospettive inedite nel mondo dell'architettura e dell'arredobagno. Innovazione e tecnologia offrono una nuova lettura delle materie che tradizionalmente disegnano gli spazi abitativi, con superfici dal carattere autentico, contaminato dal valore dello scorrere del tempo.

"Back to 2019" racconta le tendenze future che fanno già parte del nostro presente, senza rinnegare l'esperienza del passato.

Flaviker ceramic surfaces open up new horizons for the world of architecture and bathroom furnishing. Exploiting innovation and technology, they offer a fresh interpretation of the materials traditionally used to design living spaces, creating authentic surfaces that reflect the value of passing time.

"Back to 2019" tells of future trends that draw from the experience of the past to redefine our present.

VINTAGE

FLUITE
CURIE

ALPHA BETICAL INDEX

INDICE ALFABETICO

PORCELAIN TILES GRES PORCELLANATO

70	BACKSTAGE
190	COZY
214	DAKOTA
124	FORWARD
58	HANGAR
24	HYPHER
116	NO_W
94	NORDIK STONE
180	NORDIK WOOD
202	PLACE_2B ASPEN
208	PLACE_2B DUBLIN
132	QUARZITE
10	REBEL
40	RIVER
104	STILL NO_W
168	SUPREME
136	SUPREME EVO
150	SUPREME WIDE
82	URBAN CONCRETE
222	ZEN

X20 PORCELAIN TILES 20 MM GRES PORCELLANATO 20 MM

236	BACKSTAGE
250	COZY
254	DAKOTA
244	FORWARD
234	HANGAR
230	HYPHER
242	NO_W
238	NORDIK STONE
248	NORDIK WOOD
252	PLACE_2B
228	REBEL
232	RIVER
246	SHADOW
240	STILL NO_W

CONTEMPORARY WALL TILES RIVESTIMENTI CONTEMPORANEI

268	W_ALL
260	W_ALL TONES

276 TECHNICAL INFORMATION INFORMAZIONI TECNICHE

INDEX BY SIZES

INDICE PER FORMATO

160x320		60x120		60x60	
HYPHER	24	BACKSTAGE	70	BACKSTAGE	70
REBEL	10	HANGAR	58	FORWARD	124
RIVER	40	HYPHER	24	HYPHER	24
STILL NO_W	104	NO_W	116	NO_W	116
SUPREME EVO	136	NORDIK STONE	94	NORDIK STONE	94
SUPREME WIDE	150	REBEL	10	NORDIK WOOD	180
120x270		RIVER	40	REBEL	10
HYPHER	24	SUPREME	168	RIVER	40
REBEL	10	SUPREME WIDE	150	SUPREME	168
SUPREME EVO	136	SUPREME EVO	136	URBAN CONCRETE	82
120x240		30x120		30x60	
HANGAR	58	BACKSTAGE	70	FORWARD	124
RIVER	40	DAKOTA	214	HANGAR	58
STILL NO_W	104	HYPHER	24	HYPHER	24
SUPREME WIDE	150	SUPREME	168	NORDIK STONE	94
26x200		20x120		SUPREME	168
COZY	190	COZY	190	URBAN CONCRETE	82
NORDIK WOOD	180	DAKOTA	214	REBEL	10
40x170		NORDIK WOOD	180	RIVER	40
DAKOTA	214	PLACE_2B ASPEN	202	10x60	
PLACE_2B ASPEN	202	PLACE_2B DUBLIN	208	RIVER	40
20x170		ZEN	222	20x40	
DAKOTA	214	90x90		BACKSTAGE	70
PLACE_2B ASPEN	202	NORDIK STONE	94	FORWARD	124
PLACE_2B DUBLIN	208	80x80		8,5x35	
ZEN	222	BACKSTAGE	70	BACKSTAGE	70
160x160		HANGAR	58	NO_W	116
STILL NO_W	104	HYPHER	24	PLACE_2B ASPEN	202
80x160		REBEL	10	PLACE_2B DUBLIN	208
HANGAR	58	STILL NO_W	104	30x30	
STILL NO_W	104	SUPREME WIDE	150	QUARZITE	132
SUPREME WIDE	150	URBAN CONCRETE	82	RIVER	40
120x120		40x80		15x30	
HANGAR	58	BACKSTAGE	70	QUARZITE	132
HYPHER	24	FORWARD	124	10x30	
NORDIK STONE	94	NO_W	116	SUPREME	168
REBEL	10	STILL NO_W	104	20x20	
RIVER	40	URBAN CONCRETE	82	BACKSTAGE	70
STILL NO_W	104	20x80		FORWARD	124
SUPREME WIDE	150	DAKOTA	214		
SUPREME EVO	136				

**GRES
PORCELLANATO**

PORCELAIN TILES

**PRINCIPALI
FORMATI
DISPONIBILI**

MAIN SIZES
AVAILABLE

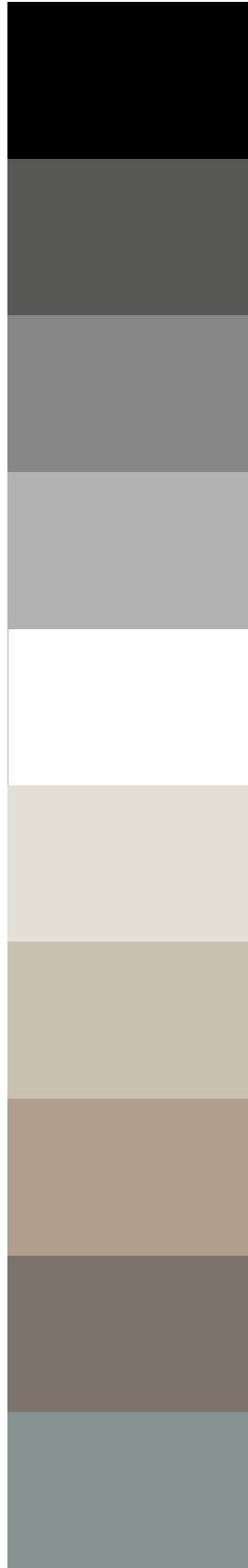

STONE PIETRA

NORDIK STONE PAG 94	STILL NO_W WIDE PAG 104	NO_W PAG 116	FORWARD PAG 124	QUARZITE PAG 132
120x120 60x120 90x90 60x60 30x60	160x320 120x240 160x160 80x160 120x120 80x80 40x80	60x120 40x80 60x60 8,5x35	40x80 60x60 30x60 20x40 20x20	30x30 15x30
BLACK	COAL	COAL	BLACK	ANTRACITE
	GREY			
ASH	GRAY	GRAY	GREY	GRIGIO
				BIANCO
SAND	SAND	SAND	SAND	BEIGE
		EARTH	EARTH	

MARBLE MARMO

SUPREME EVO WIDE PAG 136	SUPREME WIDE PAG 150	SUPREME PAG 168
160x320 120x270 120x120 60x120	160x320 120x240 80x160 120x120 60x120 80x80	60x120 30x120 60x60 30x60 10x30
CLASSIC MARQUINIA	BLACK DELUXE	
NOIR LAURENT		
GREY AMANI		
INVISIBLE SELECT		SILVER DREAM
STATUARIO SUPERIOR	STATUARIO VENATO PURE STATUARIO	ROYAL STATUARIO
ANTIQUE WHITE	CALACATTA EXTRA	GOLDEN CALACATTA
	ONYX PRESTIGE	ONYX PRESTIGE
	EXOTIC BROWN	EXOTIC BROWN

CONTEMPORARY CONTEMPORANEO

REBEL WIDE PAG 10	HYPER WIDE PAG 24	RIVER WIDE PAG 40	HANGAR WIDE PAG 58	BACKSTAGE PAG 70	URBAN CONCRETE PAG 82			
160x320 120x270 120x120 60x120 80x80 60x60 30x60	160x320 120x270 120x120 60x120 30x120 80x80 60x60 30x60 30x60	160x320 120x240 120x120 60x120 60x60 30x60 30x30 10x60	120x240 80x160 120x120 60x120 80x80 30x60	60x120 30x120 40x80 40x80 60x60 20x40 8,5x35 20x20	80x80 40x80 60x60 30x60			
NIGHT			LEAD	LEAD	COAL	GRAPHITE	NIGHT	
			SILVER	GREY		SMOKE	SMOKE	
			WHITE	SILVER	ECRU	ASH	ASH	FOG
					MOON			WHITE
						SAND	BISQUE	GREIGE
			BRASS		EARTH		TAN	NUT
			BRONZE	TAUPE			SPICY	
EMERALD								

WOOD LEGNO

NORDIK WOOD PAG 180	COZY PAG 190	PLACE_2B ASPEN PAG 202	PLACE_2B DUBLIN PAG 208	DAKOTA PAG 214	ZEN PAG 222
26x200 20x120 60x60	26x200 20x120	40x170 20x170 20x120 8,5x35	20x170 20x120 8,5x35	40x170 20x170 30x120 20x120 20x80	20x170 20x120
SMOKED		GREY			
				TORTORA	
	BARK			GRIGIO	
BEIGE	DESERT				BONE
GOLD	HONEY	NATURAL	BEIGE	NATURALE	HONEY
BROWN	HAVANA	HAVANA	TAUPE	AVANA	CAMEL
	BROWN		SMOKED		OAK

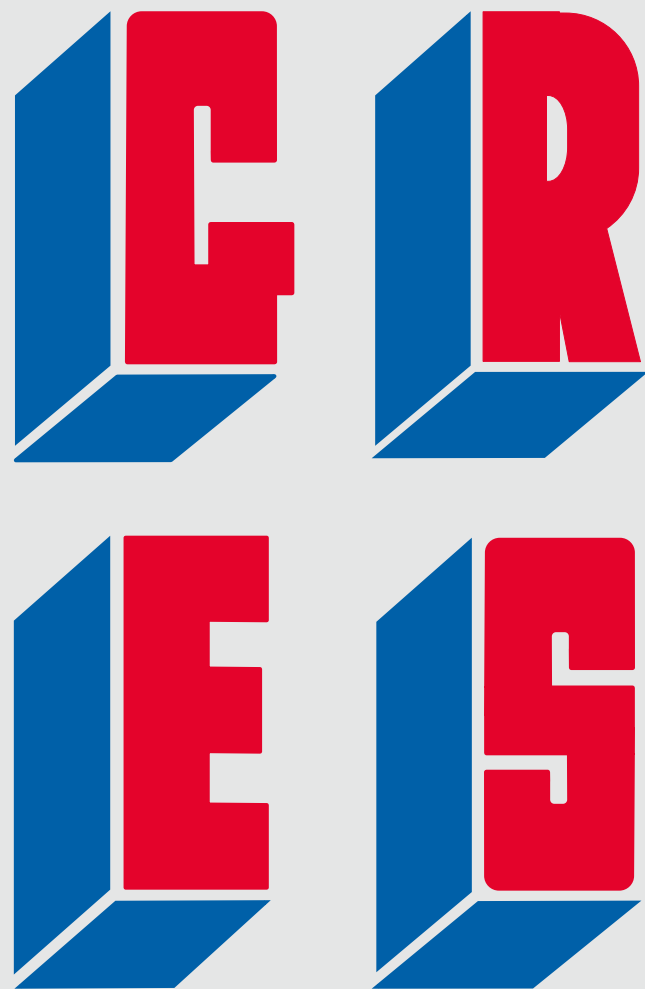

PORCELAIN TILES

GRES PORCELLANATO

CONTEMPORARY CONTEMPORANEI

- 10 REBEL
- 24 HYPER
- 40 RIVER
- 58 HANGAR
- 70 BACKSTAGE
- 82 URBAN CONCRETE

STONE PIETRA

- 94 NORDIK STONE
- 104 STILL NO_W
- 116 NO_W
- 124 FORWARD
- 132 QUARZITE

MARBLE MARMO

- 136 SUPREME EVO
- 150 SUPREME WIDE
- 168 SUPREME

WOOD LEGNO

- 180 NORDIK WOOD
- 190 COZY
- 202 PLACE_2B ASPEN
- 208 PLACE_2B DUBLIN
- 214 DAKOTA
- 222 ZEN

REBEL

WIDE
SUPERSIZE SLABS

LASTRE IN GRES PORCELLANATO A MASSA COLORATA / FULL BODY COLORED PORCELAIN SLABS

SUPERFICI / SURFACES



FORMATI / SIZES

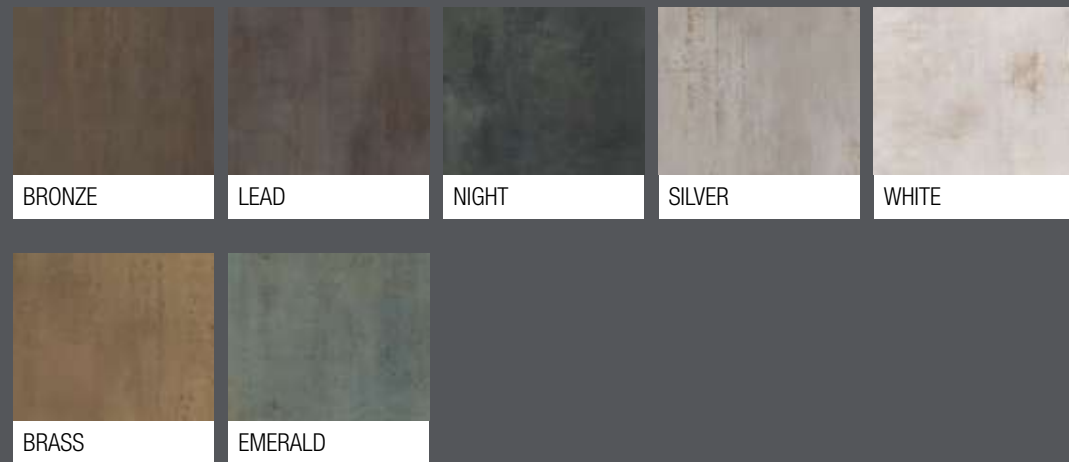
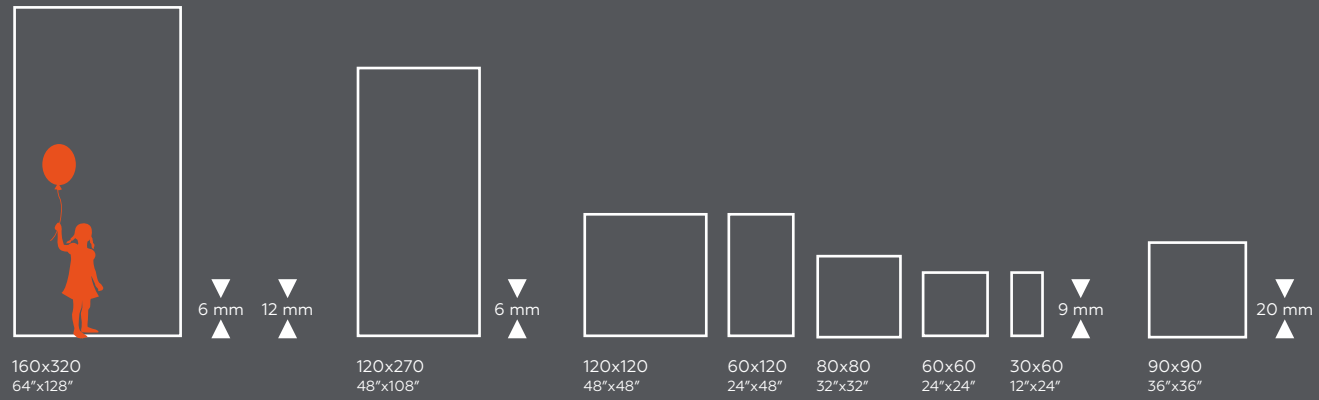

REBEL WHITE 120X270, 80X80, BRONZE 160X320
SUPREME NOIR LAURENT LUX 120X240

REBEL

WIDE
SUPERSIZE SLABS

LASTRE IN GRES PORCELLANATO A MASSA COLORATA
FULL BODY COLORED PORCELAIN SLABS



REBEL LEAD 120X270, WHITE 60X120



REBEL LEAD 60X120

BRONZE

±6 mm

* **160x320** RETT. **0003963** M. 168,00

* **120x270** RETT. **0003970** M. 132,00

±9 mm

120x120 RETT. **0003758** M. 102,00

60x120 RETT. **0004046** M. 70,00

80x80 RETT. **0004060** M. 70,00

60x60 RETT. **0004095** M. 53,50

30x60 RETT. **0004100** M. 48,00

X20 R11 ±20 mm

90x90 RETT. **0004251** M. 99,00

Per la serie completa vedi pag.: 228
For the complete collection see at page: 228





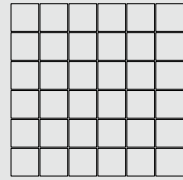





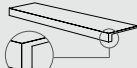

* Fino ad esaurimento scorte l'art. verrà consegnato a spessore 7 mm. / The item will be delivered 7 mm thick until stocks are exhausted.

30x30

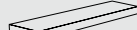

0004488 ±9 mm
MOSAICO BRONZE RETT.
M. 104,00 

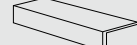
±9 mm

	BATTISCOPA 	5,5x60
	RETT. 0004169	P. 6,50
	BATTISCOPA 	5,5x80
	RETT. 0004065	P. 8,00
	GRADONE PLUS 	32x120x4,5x2
	RETT. 0004070	P. 169,00
	ANGOLARE PLUS SX 	32x120x4,5x2
	RETT. 0004075	P. 196,00
	ANGOLARE PLUS DX 	32x120x4,5x2
	RETT. 0004080	P. 196,00
	GRADONE JOLLY 	40x120x20
	RETT. 0004085	P. 169,00

120x270

LEAD

±6 mm

* **120x270** RETT. **0003972** M. 132,00

±9 mm

120x120 RETT. **0003760** M. 102,00

60x120 RETT. **0004048** M. 70,00

80x80 RETT. **0004062** M. 70,00

60x60 RETT. **0004097** M. 53,50

30x60 RETT. **0004102** M. 48,00

X20 R11 ±20 mm

90x90 RETT. **0004252** M. 99,00

Per la serie completa vedi pag.: 228
For the complete collection see at page: 228





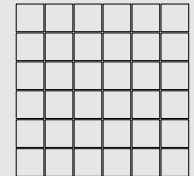





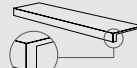

* Fino ad esaurimento scorte l'art. verrà consegnato a spessore 7 mm. / The item will be delivered 7 mm thick until stocks are exhausted.

30x30

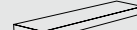

0004490 ±9 mm
MOSAICO LEAD RETT.
M. 104,00 

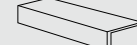
±9 mm

	BATTISCOPA 	5,5x60
	RETT. 0004171	P. 6,50
	BATTISCOPA 	5,5x80
	RETT. 0004067	P. 8,00
	GRADONE PLUS 	32x120x4,5x2
	RETT. 0004072	P. 169,00
	ANGOLARE PLUS SX 	32x120x4,5x2
	RETT. 0004077	P. 196,00
	ANGOLARE PLUS DX 	32x120x4,5x2
	RETT. 0004082	P. 196,00
	GRADONE JOLLY 	40x120x20
	RETT. 0004087	P. 169,00

120x270

NIGHT

± 12 mm

163,5x323 NAT. **0003793** M. 190,00

± 6 mm

* **160x320** RETT. **0003964** M. 168,00

* **120x270** RETT. **0003971** M. 132,00

± 9 mm

120x120 RETT. **0003759** M. 102,00

60x120 RETT. **0004047** M. 70,00

80x80 RETT. **0004061** M. 70,00

60x60 RETT. **0004096** M. 53,50

30x60 RETT. **0004101** M. 48,00

Per la serie completa vedi pag.: 228
For the complete collection see at page: 228

* Fino ad esaurimento scorte l'art. verrà consegnato a spessore 7 mm. / The item will be delivered 7 mm thick until stocks are exhausted.

30x30

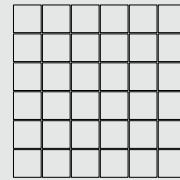

0004489 ± 9 mm
MOSAICO NIGHT RETT.
M. 104,00 

± 9 mm

 **BATTISCOPA**  5,5x60
RETT. **0004170** P. 6,50

 **BATTISCOPA**  5,5x80
RETT. **0004066** P. 8,00

 **GRADONE PLUS**  32x120x4,5x2
RETT. **0004071** P. 169,00

 **ANGOLARE PLUS SX**  32x120x4,5x2
RETT. **0004076** P. 196,00

 **ANGOLARE PLUS DX**  32x120x4,5x2
RETT. **0004081** P. 196,00

 **GRADONE JOLLY**  40x120x20
RETT. **0004086** P. 169,00

160x320

SILVER

± 6 mm

* **120x270** RETT. **0003973** M. 132,00

± 9 mm

120x120 RETT. **0003761** M. 102,00

60x120 RETT. **0004049** M. 70,00

80x80 RETT. **0004063** M. 70,00

60x60 RETT. **0004098** M. 53,50

30x60 RETT. **0004103** M. 48,00

X20 R11 ± 20 mm

90x90 RETT. **0004253** M. 99,00

Per la serie completa vedi pag.: 228
For the complete collection see at page: 228



* Fino ad esaurimento scorte l'art. verrà consegnato a spessore 7 mm. / The item will be delivered 7 mm thick until stocks are exhausted.

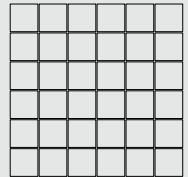

30x30



0004491 ± 9 mm
MOSAICO SILVER RETT.
M. 104,00 

± 9 mm

 **BATTISCOPA**  5,5x60
RETT. **0004172** P. 6,50

 **BATTISCOPA**  5,5x80
RETT. **0004068** P. 8,00

 **GRADONE PLUS**  32x120x4,5x2
RETT. **0004073** P. 169,00

 **ANGOLARE PLUS SX**  32x120x4,5x2
RETT. **0004078** P. 196,00

 **ANGOLARE PLUS DX**  32x120x4,5x2
RETT. **0004083** P. 196,00

 **GRADONE JOLLY**  40x120x20
RETT. **0004088** P. 169,00

60x60

WHITE



60x120

±6 mm

* 120x270 RETT. 0003974 M. 132,00

±9 mm

120x120 RETT. 0003762 M. 102,00

60x120 RETT. 0004050 M. 70,00

80x80 RETT. 0004064 M. 70,00

60x60 RETT. 0004099 M. 53,50

30x60 RETT. 0004104 M. 48,00

Per la serie completa vedi pag.: 228
For the complete collection see at page: 228





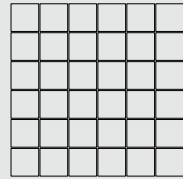







* Fino ad esaurimento scorte l'art. verrà consegnato a spessore 7 mm. / The item will be delivered 7 mm thick until stocks are exhausted.

30x30

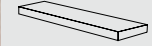

0004492 ±9 mm
MOSAICO WHITE RETT.
M. 104,00 

±9 mm

	BATTISCOPA		5,5x60
	RETT.	0004173	P. 6,50
	BATTISCOPA		5,5x80
	RETT.	0004069	P. 8,00
	GRADONE PLUS		32x120x4,5x2
	RETT.	0004074	P. 169,00
	ANGOLARE PLUS SX		32x120x4,5x2
	RETT.	0004079	P. 196,00
	ANGOLARE PLUS DX		32x120x4,5x2
	RETT.	0004084	P. 196,00
	GRADONE JOLLY		40x120x20
	RETT.	0004089	P. 169,00

120x270

±6 mm

* 120x270 RETT. 0004960 M. 132,00

±9 mm

120x120 RETT. 0004945 M. 70,00

60x120 RETT. 0004052 M. 70,00

* Fino ad esaurimento scorte l'art. verrà consegnato a spessore 7 mm. / The item will be delivered 7 mm thick until stocks are exhausted.

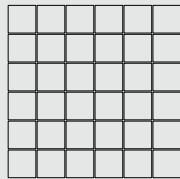

30x30

0004494 ±9 mm
MOSAICO EMERALD RETT.
M. 104,00 

±9 mm

	BATTISCOPA		5,5x120
	RETT.	0004234	P. 9,50

REBEL

WIDE
SUPERSIZE SLABS

LASTRE IN GRES PORCELLANATO A MASSA COLORATA
FULL BODY COLORED PORCELAIN SLABS

BRASS

±9 mm

120x120 RETT.	0004944	M. 70,00
60x120 RETT.	0004051	M. 70,00

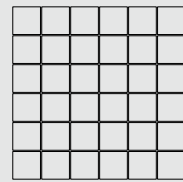

30x30

0004493 ±9 mm
MOSAICO BRASS RETT.
M. 104,00

±9 mm

	BATTISCOPA	5,5x120
RETT.	0004233	P. 9,50



REBEL SILVER 120X120, LEAD 120X270

LASTRE IN GRES PORCELLANATO A MASSA COLORATA - CLASSIFICAZIONE SECONDO NORME EN 14411 (ISO 13006) ALLEGATO G GRUPPO B1a
FULL BODY COLORED PORCELAIN SLABS - CLASSIFICATION IN ACCORDANCE WITH EN 14411 (ISO 13006) ANNEX G GROUP B1A

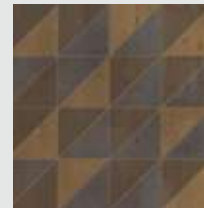

30X30
0004344
MOSAICO TRIS HOT RETT.
M.249,00



30X30
0004343
MOSAICO TRIS COLD RETT.
M.249,00

0,5x120	0000086	Matita Alluminio	P. 20,90
0,5x120	0000087	Matita Alluminio White	P. 34,90
0,5x120	0000088	Matita Alluminio Black	P. 34,90
0,5x120	0000556	Matita Alluminio Rame	P. 34,90
0,5x120	0000557	Matita Alluminio Bronzo	P. 34,90

Articoli realizzati in alluminio per l'uso a parete, adatti a raccordare piastrelle di diverso spessore (9 mm / 7 mm).

Aluminium strip for use between wall tiles of different thicknesses (9 mm / 7 mm).

F.to nominale Nominal size	F.to reale (mm) Work size (mm)	Spessore Thickness	Tipologia imballo Type of packing	Lastre/Imballo Slabs/Packing	Pz/Imballo Pcs/Packing	Mq/Scatola Sqm/Box	Kg/Scatola Kg/Box	Scatole/Imballo Box/Packing	Mq totali Sqm total	Kg/Imballo Kg/Packing	Kg totali Kg total	Prezzo imballo Packing Price
163,5x323 nat	1635x3230	12mm	Cassa Crate	10	-	-	-	-	51,20	139	1660	€ 130,00
163,5x323 nat	1635x3230	12mm	Cavalletto container legno A - frame Container Rack pallet wood A - frame	22	-	-	-	-	112,64	180	3524	€ 235,00
163,5x323 nat	1635x3230	12mm	Cavalletto container metallo A - frame Container Rack pallet metal A - frame	22	-	-	-	-	112,64	180	3524	€ 400,00
160x320 / 64"x128" rett.	1596,5x3195	6 mm	Cassa Crate	14	-	-	-	-	71,68	139	1.214	€ 130,00
			Cavalletto container Container Rack pallet	36	-	-	-	-	184,32	180	2.945	€ 235,00
120x270 / 48"x108" rett.	1194x2700	6 mm	Cassa Crate	18	-	-	-	-	58,32	112	987	€ 115,00
			Cavalletto Rack pallet	36	-	-	-	-	116,64	115	1.865	€ 135,00
			Cavalletto container Container Rack pallet	36	-	-	-	-	116,64	130	1.880	€ 210,00
120x120 / 48"x48" rett.	1194x1194	9 mm	Pallet con sponde Pallet with sides	36	2	2,88	56,16	18	51,84	40	1.051	-
60x120 / 24"x48" rett.	596x1194	9 mm	Pallet	60	2	1,44	28,00	30	43,20	20	860	-
80x80 / 32"x32" rett.	797,25x797,25	9 mm	Pallet	88	2	1,28	25,00	44	56,32	20	1.120	-
60x60 / 24"x24" rett.	596x596	9 mm	Pallet	120	3	1,08	21,20	40	43,20	20	868	-
30x60 / 12"x24" rett.	297x596	9 mm	Pallet	240	6	1,08	21,20	40	43,20	20	868	-
90x90 / 36"x36" rett.	896x896	20 mm	Pallet	30	1	0,81	36,60	30	24,30	20	1.118	-













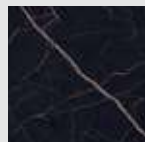
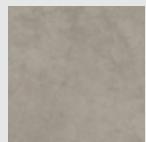
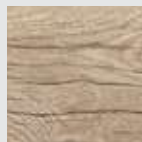



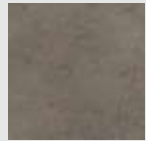

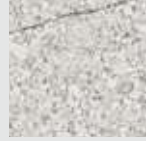
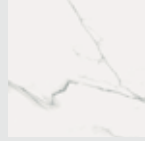
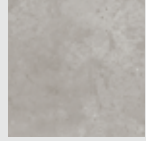

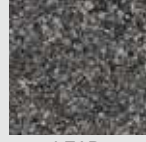

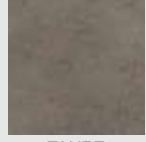
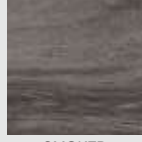

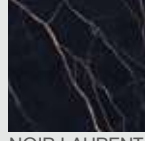
I pezzi speciali, per effetto delle lavorazioni, possono presentare variazioni di tonalità. Due to working process, special trims may show variations in tonality. L'unità minima di vendita per tutti gli articoli (fondi, decori e pezzi speciali) è la scatola completa. The minimum sales quantity for all items (plain tiles, decorations and special trims) is one full box. I dati relativi agli imballi sono aggiornati al momento della stampa del catalogo e pertanto possono subire variazioni nel corso del tempo. Data referring to packaging have been update at time of printing; the actual data may be slightly different. Approfondimenti sugli imballi a pag. 282 dell'area tecnica. Details concerning packaging available at page 282 inside technical area.

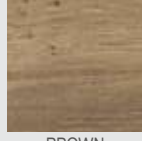
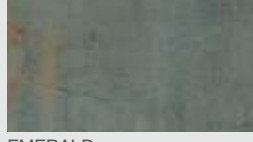
REBEL MULTIPLE SENSATIONS

WIDE
SUPERSIZE SLABS

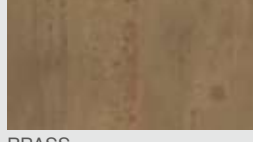
MULTIPLE SENSATIONS è la materioteca di FLAVIKER, un contenitore di materie diverse sapientemente combinate insieme per dare vita ad atmosfere sorprendenti ed in linea con le principali tendenze del design contemporaneo.

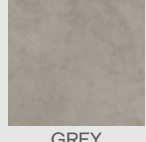
MULTIPLE SENSATIONS from FLAVIKER is a collection of different materials which can be combined to create striking and original atmospheres in line with the latest trends in contemporary design.

REBEL	RIVER	SUPREME/ SUPREME EVO	HYPER	NORDIK WOOD
 BRONZE	 ECRU	 NOIR LAURENT	 GREY	 BEIGE
 LEAD	 MOON	 STAT. SUPERIOR	 TAUPE	 GOLD
 NIGHT	 MOON	 PURE STATUARIO	 SILVER	 BEIGE
 SILVER	 LEAD	 INVISIBLE SELECT	 TAUPE	 SMOKED
 WHITE	 ECRU	 NOIR LAURENT	 TAUPE	 BROWN
 EMERALD	 ECRU	 ANTIQUE WHITE	 SILVER	 GOLD
 BRASS	 EARTH	 ANTIQUE WHITE	 GREY	 GOLD



REBEL SILVER, BRONZE
SUPREME EVO INVISIBLE SEL. LUX*



REBEL BRONZE, NIGHT
RIVER ECRU



REBEL NIGHT
HYPER SILVER



REBEL LEAD
SUPREME EVO STATUARIO SUPERIOR

HYPER

WIDE
SUPERSIZE SLABS

LASTRE IN GRES PORCELLANATO A MASSA COLORATA / FULL BODY COLORED PORCELAIN SLABS

SUPERFICI / SURFACES



Naturale
Natural



Lappato
Honed



Grip
Antislippery

FORMATI / SIZES

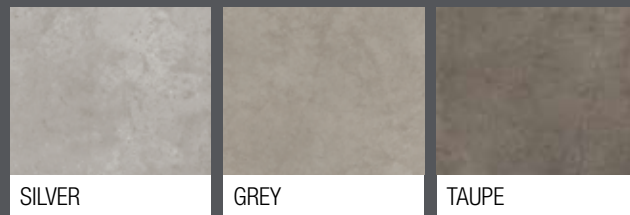
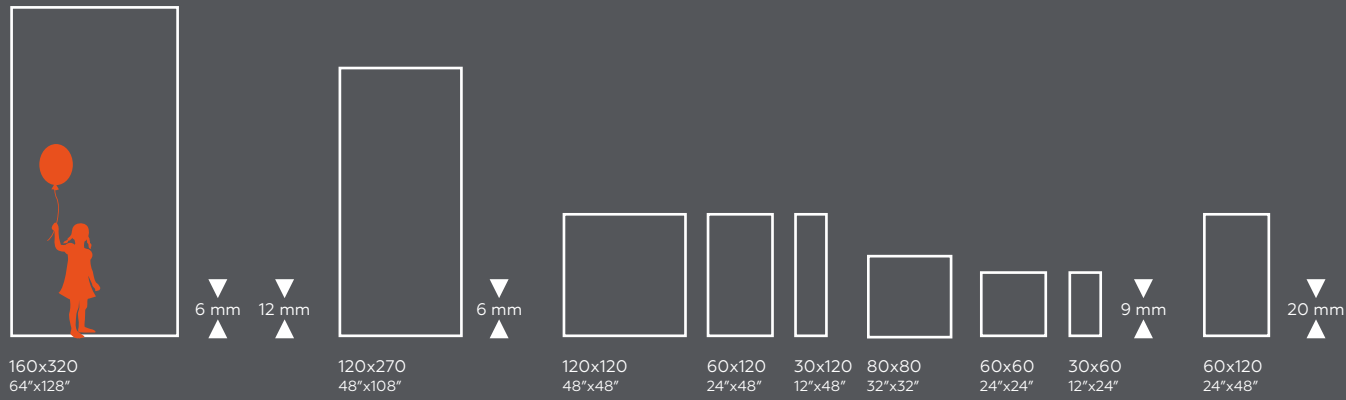

HYPER SILVER RETT. 160X320 - 80X80

HYPER

WIDE
SUPERSIZE SLABS

LASTRE IN GRES PORCELLANATO A MASSA COLORATA
FULL BODY COLORED PORCELAIN SLABS



HYPER GREY 120X270 RETT. - GREY 120X120 RETT.



HYPER TAUPE 80X80 RETT. 120X270
SUPREME EVO NOIR LAURENT LUX*



TAUPE

±6 mm

* 120x270 RETT.	0002444	M. 132,00
* 120x270 LAPP. RETT.	0002466	M. 149,00

±9 mm

120x120 RETT.	0002450	M. 102,00
120x120 LAPP. RETT.	0002472	M. 119,00
60x120 RETT.	0002453	M. 70,00
60x120 LAPP. RETT.	0002475	M. 80,00
30x120 RETT.	0003091	M. 70,00
80x80 RETT.	0002459	M. 70,00
60x60 RETT.	0003025	M. 53,50
60x60 LAPP. RETT.	0003088	M. 66,00
30x60 RETT.	0003170	M. 48,00

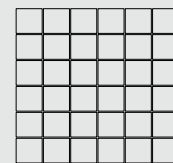

30x30
0003660 ±9 mm
MOSAICO TAUPE RETT.
M. 104,00

GRIP R11 P3		±9 mm
60x60 GRIP	0003034	M. 53,50

X20 R11		±20 mm
60x120 RETT.	0002772	M. 99,00

Per la serie completa vedi pag.: 230
For the complete collection see at page: 230

* Fino ad esaurimento scorte l'art. verrà consegnato a spessore 7 mm.
The item will be delivered 7 mm thick until stocks are exhausted.

±9 mm

	BATTISCOPA	5,5x60
	RETT.	0003028 P. 6,50
	LAPP. RETT.	0003148 P. 8,00
	BATTISCOPA	5,5x80
	RETT.	0003124 P. 8,00
	BATTISCOPA	5,5x120
	LAPP. RETT.	0003136 P. 12,50
	GRADONE PLUS	32x120x4,5x2
	RETT.	0003127 P. 169,00
	LAPP. RETT.	0003139 P. 179,00
	ANGOLARE PLUS SX	32x120x4,5x2
	RETT.	0003130 P. 196,00
	LAPP. RETT.	0003142 P. 206,00
	ANGOLARE PLUS DX	32x120x4,5x2
	RETT.	0003133 P. 196,00
	LAPP. RETT.	0003145 P. 206,00
	GRADONE JOLLY	40x120x20
	RETT.	0004524 P. 169,00
	LAPP. RETT.	0004527 P. 179,00

60x120

GREY

±6 mm

* 120x270 RETT.	0002443	M. 132,00
* 120x270 LAPP. RETT.	0002465	M. 149,00

±9 mm

120x120 RETT.	0002449	M. 102,00
120x120 LAPP. RETT.	0002471	M. 119,00
60x120 RETT.	0002452	M. 70,00
60x120 LAPP. RETT.	0002474	M. 80,00
30x120 RETT.	0003090	M. 70,00
80x80 RETT.	0002458	M. 70,00
60x60 RETT.	0003024	M. 53,50
60x60 LAPP. RETT.	0003087	M. 66,00
30x60 RETT.	0003169	M. 48,00

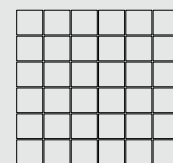

30x30
0003659 ±9 mm
MOSAICO GREY RETT.
M. 104,00

GRIP R11 P3		±9 mm
60x60 GRIP	0003033	M. 53,50

X20 R11		±20 mm
60x120 RETT.	0002771	M. 99,00

Per la serie completa vedi pag.: 230
For the complete collection see at page: 230

* Fino ad esaurimento scorte l'art. verrà consegnato a spessore 7 mm.
The item will be delivered 7 mm thick until stocks are exhausted.

±9 mm

	BATTISCOPA	5,5x60
	RETT.	0003027 P. 6,50
	LAPP. RETT.	0003147 P. 8,00
	BATTISCOPA	5,5x80
	RETT.	0003123 P. 8,00
	BATTISCOPA	5,5x120
	LAPP. RETT.	0003135 P. 12,50
	GRADONE PLUS	32x120x4,5x2
	RETT.	0003126 P. 169,00
	LAPP. RETT.	0003138 P. 179,00
	ANGOLARE PLUS SX	32x120x4,5x2
	RETT.	0003129 P. 196,00
	LAPP. RETT.	0003141 P. 206,00
	ANGOLARE PLUS DX	32x120x4,5x2
	RETT.	0003132 P. 196,00
	LAPP. RETT.	0003144 P. 206,00
	GRADONE JOLLY	40x120x20
	RETT.	0004523 P. 169,00
	LAPP. RETT.	0004526 P. 179,00

80x80

SILVER

± 12 mm

163,5x323 NAT. **0003794** M. 170,00

± 6 mm

* **160x320** RETT. **0002436** M. 168,00

* **120x270** RETT. **0002442** M. 132,00

* **120x270** LAPP. RETT. **0002464** M. 149,00

± 9 mm

120x120 RETT. **0002448** M. 102,00

120x120 LAPP. RETT. **0002470** M. 119,00

60x120 RETT. **0002451** M. 70,00

60x120 LAPP. RETT. **0002473** M. 80,00

30x120 RETT. **0003089** M. 70,00

80x80 RETT. **0002457** M. 70,00

60x60 RETT. **0003023** M. 53,50

60x60 LAPP. RETT. **0003086** M. 66,00

30x60 RETT. **0003168** M. 48,00

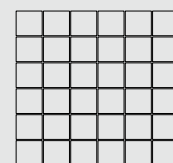

30x30

0003658 ± 9 mm
MOSAICO SILVER RETT.
M. 104,00

GRIP R11 P3 ± 9 mm

60x60 GRIP **0003032** M. 53,50

X20 R11 ± 20 mm

60x120 RETT. **0002770** M. 99,00

± 9 mm

BATTISCOPA 5,5x60

RETT. **0003026** P. 6,50

LAPP. RETT. **0003146** P. 8,00

BATTISCOPA 5,5x80

RETT. **0003122** P. 8,00

BATTISCOPA 5,5x120

LAPP. RETT. **0003134** P. 12,50

GRADONE PLUS 32x120x4,5x2

RETT. **0003125** P. 169,00

LAPP. RETT. **0003137** P. 179,00

ANGOLARE PLUS SX 32x120x4,5x2

RETT. **0003128** P. 196,00

LAPP. RETT. **0003140** P. 206,00

ANGOLARE PLUS DX 32x120x4,5x2

RETT. **0003131** P. 196,00

LAPP. RETT. **0003143** P. 206,00

GRADONE JOLLY 40x120x20

RETT. **0004522** P. 169,00

LAPP. RETT. **0004525** P. 179,00

160x320

Per la serie completa vedi pag.: 230
For the complete collection see at page: 230

* Fino ad esaurimento scorte l'art. verrà consegnato a spessore 7 mm.
The item will be delivered 7 mm thick until stocks are exhausted.

* **120x270** ± 6 mm

0003095
HYPER SILVER PATCH RETT.
M. 149,00

120x120 ± 9 mm

0003179
HYPER SILVER PATCH RETT.
M. 119,00

60x120 ± 9 mm

0003100
HYPER SILVER PATCH RETT.
M. 80,00

30x120 ± 9 mm

0003178
HYPER SILVER PATCH RETT.
M. 80,00



HYPER PATCH SILVER 120x120 RETT.
HYPER SILVER 160x320 RETT.



STREET LOVER

160x320 HYPER DEC. STREET L. SILVER A 6 mm 0003101 P. 2.450,00

120x270 HYPER DEC. STREET L. SILVER A 6 mm 0003103 P. 1.500,00

120x270 HYPER DEC. STREET L. GREY A 6 mm 0003104 P. 1.500,00

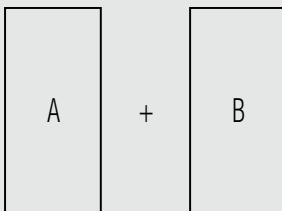

STREET LOVER

160x320 HYPER DEC. STREET L. SILVER B 6 mm 0003102 P. 2.450,00

120x270 HYPER DEC. STREET L. SILVER B 6 mm 0003184 P. 1.500,00

120x270 HYPER DEC. STREET L. GREY B 6 mm 0003185 P. 1.500,00

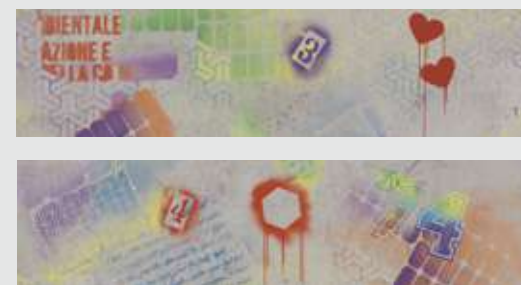

30x120 HYPER DEC. STREET L. SILVER MIX2 9 mm 0003114 P. 145,00



ROSE

160x320 HYPER DEC. ROSE SILVER 6 mm 0003187 P. 2.450,00

120x270 HYPER DEC. ROSE SILVER 6 mm 0003190 P. 1.500,00

120x270 HYPER DEC. ROSE GREY 6 mm 0003191 P. 1.500,00

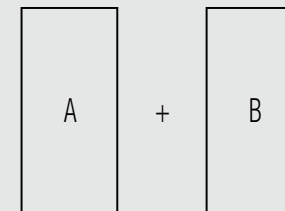

TIGER

160x320 HYPER DEC. TIGER SILVER 6 mm 0003186 P. 2.450,00

120x270 HYPER DEC. TIGER SILVER 6 mm 0003188 P. 1.500,00

120x270 HYPER DEC. TIGER GREY 6 mm 0003189 P. 1.500,00

HYPER

WIDE
SUPERSIZE SLABS

LASTRE IN GRES PORCELLANATO A MASSA COLORATA
FULL BODY COLORED PORCELAIN SLABS

SLIM PACK

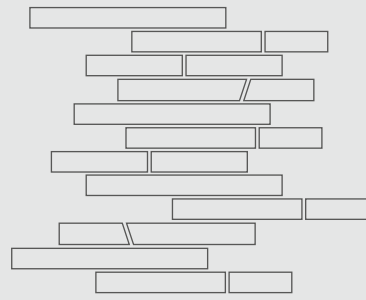

SILVER	0003115	M. 104,00
GREY	0003116	M. 104,00
TAUPE	0003117	M. 104,00

1 co = 0,54 mq

A = 4 PZ/BOX - 7,5x60	E = 1 PZ/BOX - 7,5x40
B = 4 PZ/BOX - 7,5x40	F = 1 PZ/BOX - 7,5x20
C = 4 PZ/BOX - 7,5x20	G = 1 PZ/BOX - 7,5x20
D = 4 PZ/BOX - 7,5x30	H = 1 PZ/BOX - 7,5x40

ESEMPIO DI POSA (1 SCATOLA = 0,54 MQ)
LAYING EXAMPLE (1 BOX = 0,54 MQ)

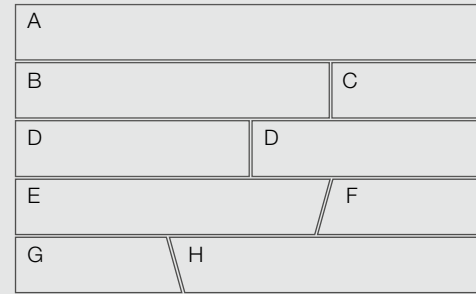

HYPER TAUPE RETT. 60X120



HYPER TAUPE SLIM PACK

LASTRE IN GRES PORCELLANATO A MASSA COLORATA - CLASSIFICAZIONE SECONDO NORME EN 14411 (ISO 13006) ALLEGATO G GRUPPO BIa
FULL BODY COLORED PORCELAIN SLABS - CLASSIFICATION IN ACCORDANCE WITH EN 14411 (ISO 13006) ANNEX G GROUP BIa



F.to nominale Nominal size	F.to reale (mm) Work size (mm)	Spessore Thickness	Tipologia imballo Type of packing	Lastre/Imballo Slabs/Packing	Pz/Imballo Pcs/Packing	Mq/Scatola SqM/Box	Kg/Scatola Kg/Box	Scatole/Imballo Box/Packing	Mq totali SqM total	Kg/Imballo Kg/Packing	Kg totali Kg total	Prezzo imballo Packing Price
163,5x323 nat	1635x3230	12mm	Cassa Crate	10	-	-	-	-	51,20	139	1660	€ 130,00
163,5x323 nat	1635x3230	12mm	Cavalletto container legno A - frame Container Rack pallet wood A - frame	22	-	-	-	-	112,64	180	3524	€ 235,00
163,5x323 nat	1635x3230	12mm	Cavalletto container metallo A - frame Container Rack pallet metal A - frame	22	-	-	-	-	112,64	180	3524	€ 400,00
160x320 / 64"x128" rett.	1596,5x3195	6 mm	Cassa Crate	14	-	-	-	-	71,68	139	1.214	€ 130,00
			Cavalletto container Container Rack pallet	36	-	-	-	-	184,32	180	2.945	€ 235,00
120x270 / 48"x108" rett./lapp.	1194x2700	6 mm	Cassa Crate	18	-	-	-	-	58,32	112	987	€ 115,00
			Cavalletto Rack pallet	36	-	-	-	-	116,64	115	1.865	€ 135,00
			Cavalletto container Container Rack pallet	36	-	-	-	-	116,64	130	1.880	€ 210,00
120x120 / 48"x48" rett./lapp.	1194x1194	9 mm	Pallet con sponde Pallet with sides	36	2	2,88	56,16	18	51,84	40	1.051	-
60x120 / 24"x48" rett./lapp.	596x1194	9 mm	Pallet	60	2	1,44	28,00	30	43,20	20	860	-
30x120 / 12"x48" rett.	297x1194	9 mm	Pallet	144	4	1,44	28,00	36	51,84	20	1.028	-
80x80 / 32"x32" rett.	797,25x797,25	9 mm	Pallet	88	2	1,28	25,00	44	56,32	20	1.120	-
60x60 / 24"x24" rett.	596x596	9 mm	Pallet	120	3	1,08	21,20	40	43,20	20	868	-
30x60 / 12"x24" rett.	297x596	9 mm	Pallet	240	6	1,08	21,20	40	43,20	20	868	-
60x120 / 24"x48" rett.	596x1195	20 mm	Pallet	30	1	0,72	32,65	30	21,60	20	1000	-

0,5x120	0000086	MATITA ALLUMINIO	P. 20,90	4
0,5x120	0000087	MATITA ALLUMINIO WHITE	P. 34,90	4
0,5x120	0000088	MATITA ALLUMINIO BLACK	P. 34,90	4

0,5x120	0000556	MATITA ALLUMINIO RAME	P. 34,90	4
0,5x120	0000557	MATITA ALLUMINIO BRONZO	P. 34,90	4

Articoli realizzati in alluminio per l'uso a parete, adatti a raccordare piastrelle di diverso spessore (9 mm / 7 mm).
Aluminium strip for use between wall tiles of different thicknesses (9 mm / 7 mm).

I pezzi speciali, per effetto delle lavorazioni, possono presentare variazioni di tonalità. Due to working process, special trims may show variations in tonality.
L'unità minima di vendita per tutti gli articoli (fondi, decori e pezzi speciali) è la scatola completa. The minimum sales quantity for all items (plain tiles, decorations and special trims) is one full box.
I dati relativi agli imballi sono aggiornati al momento della stampa del catalogo e pertanto possono subire variazioni nel corso del tempo.
Data referring to packaging have been update at time of printing; the actual data may be slightly different.
Approfondimenti sugli imballi a pag. 282 dell'area tecnica. Details concerning packaging available at page 282 inside technical area.

HYPER MULTIPLE SENSATIONS

WIDE
SUPERSIZE SLABS

MULTIPLE SENSATIONS è la materioteca di FLAVIKER, un contenitore di materie diverse sapientemente combinate insieme per dare vita ad atmosfere sorprendenti ed in linea con le principali tendenze del design contemporaneo.

MULTIPLE SENSATIONS from FLAVIKER is a collection of different materials which can be combined to create striking and original atmospheres in line with the latest trends in contemporary design.

HYPER

RIVER

HANGAR

SUPREME/ SUPREME EVO

COZY

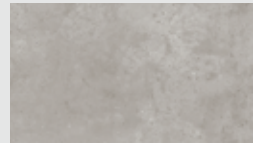

SILVER

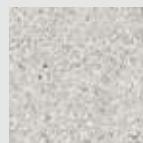

MOON



SMOKE

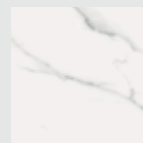

PURE STATUARIO

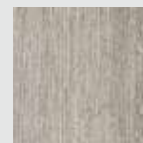

BARK

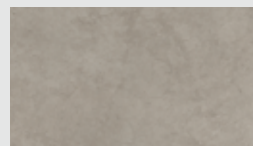

GREY



LEAD



COAL



STATUARIO VENATO

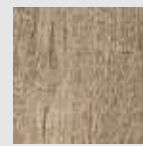

BROWN

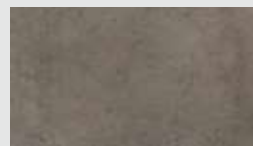

TAUPE



EARTH



SAND

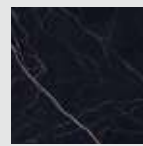

NOIR LAURENT



HAVANA



HYPER SILVER
COZY HAVANA



HYPER TAUPE
SUPREME EVO NOIR LAURENT LUX*



HYPER TAUPE
RIVER EARTH
W_ALL STONE BEIGE



HYPER GREY
SUPREME STATUARIO VENATO

RIVER

WIDE
SUPERSIZE SLABS

LASTRE IN GRES PORCELLANATO A MASSA COLORATA / FULL BODY COLORED PORCELAIN SLABS

SUPERFICI / SURFACES



Naturale
Natural



Lappato
Honed

FORMATI / SIZES

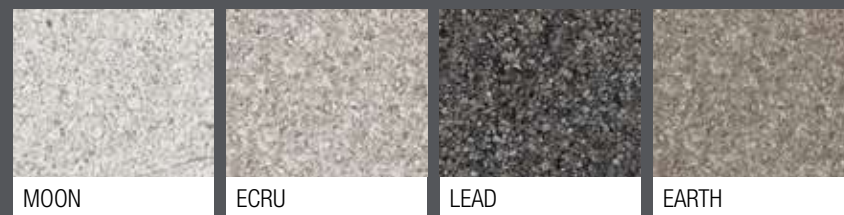
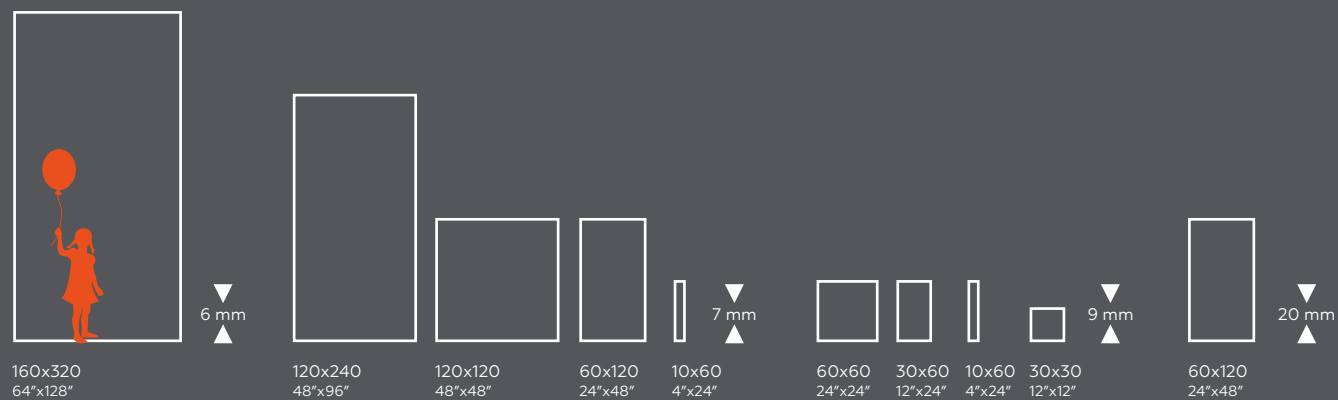

MOON

ECRU

LEAD

EARTH



RIVER EARTH

WIDE
SUPERSIZE SLABS



RIVER LEAD 120X240, 60X120, SHADE 120X240
WASHBASIN SHELF COZY BARK 26X200





RIVER MOON: 60X120
COUNTERTOP: 120X240

120x240

±7 mm





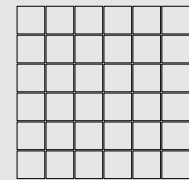



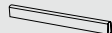

120x240	RETT.	0001757	M. 132,00
120x240	LAPP. RETT.	0002285	M. 149,00
120x120	RETT.	0001765	M. 102,00
120x120	LAPP. RETT.	0001781	M. 119,00
60x120	RETT.	0001769	M. 70,00
60x120	LAPP. RETT.	0002289	M. 80,00
10x60	RETT.	0002839	M. 57,50

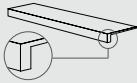
30x30

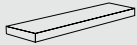

0002374 ±7 mm
MOSAICO MOON
RETT. 
M. 104,00

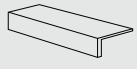
±7 mm

	BATTISCOPA 	5,5x120
	RETT.	0002325 P. 9,50
	LAPP. RETT.	0002357 P. 12,50
	GRADONE PLUS 	32x120x4,5x1,5
	RETT.	0002329 P. 169,00
	LAPP. RETT.	0002361 P. 179,00
	ANGOLARE PLUS SX 	32x120x4,5x1,5
	RETT.	0002333 P. 196,00
	LAPP. RETT.	0002365 P. 206,00
	ANGOLARE PLUS DX 	32x120x4,5x1,5
	RETT.	0002337 P. 196,00
	LAPP. RETT.	0002369 P. 206,00
	GRADONE JOLLY 	40x120x20
	RETT.	0004532 P. 169,00
	LAPP. RETT.	0004536 P. 179,00

ECRU



120x120

⌘ 6 mm

* 160x320 RETT. 0001750 M. 168,00

⌘ 7 mm

120x240 RETT. 0001758 M. 132,00

120x240 LAPP. RETT. 0002286 M. 149,00

120x120 RETT. 0001766 M. 102,00

120x120 LAPP. RETT. 0001782 M. 119,00

60x120 RETT. 0001770 M. 70,00

60x120 LAPP. RETT. 0002290 M. 80,00

10x60 RETT. 0002840 M. 57,50

X20 R11 ⌘ 20 mm

60x120 RETT. 0001789 M. 99,00

Per la serie completa vedi pag.: 232
For the complete collection see at page: 232

* Fino ad esaurimento scorte l'art. verrà consegnato a spessore 7 mm.
The item will be delivered 7 mm thick until stocks are exhausted.

30x30

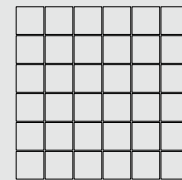



0002375 ⌘ 7 mm
MOSAICO ECRU RETT.
M. 104,00 

⌘ 7 mm

 **BATTISCOPA**  5,5x120

RETT. 0002326 P. 9,50

LAPP. RETT. 0002358 P. 12,50

 **GRADONE PLUS**  32x120x4,5x1,5

RETT. 0002330 P. 169,00

LAPP. RETT. 0002362 P. 179,00

 **ANGOLARE PLUS SX**  32x120x4,5x1,5

RETT. 0002334 P. 196,00

LAPP. RETT. 0002366 P. 206,00

 **ANGOLARE PLUS DX**  32x120x4,5x1,5

RETT. 0002338 P. 196,00

LAPP. RETT. 0002370 P. 206,00

 **GRADONE JOLLY**  40x120x20

RETT. 0004533 P. 169,00

LAPP. RETT. 0004537 P. 179,00

60x120

EARTH



⌘ 7 mm

120x240 RETT. 0001759 M. 132,00

120x240 LAPP. RETT. 0002287 M. 149,00

120x120 RETT. 0001767 M. 102,00

120x120 LAPP. RETT. 0001783 M. 119,00

60x120 RETT. 0001771 M. 70,00

60x120 LAPP. RETT. 0002291 M. 80,00

10x60 RETT. 0002841 M. 57,50

30x30

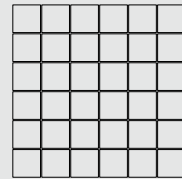



0002376 ⌘ 7 mm
MOSAICO EARTH RETT.
M. 104,00 

⌘ 7 mm

 **BATTISCOPA**  5,5x120

RETT. 0002327 P. 9,50

LAPP. RETT. 0002359 P. 12,50

 **GRADONE PLUS**  32x120x4,5x1,5

RETT. 0002331 P. 169,00

LAPP. RETT. 0002363 P. 179,00

 **ANGOLARE PLUS SX**  32x120x4,5x1,5

RETT. 0002335 P. 196,00

LAPP. RETT. 0002367 P. 206,00

 **ANGOLARE PLUS DX**  32x120x4,5x1,5

RETT. 0002339 P. 196,00

LAPP. RETT. 0002371 P. 206,00

 **GRADONE JOLLY**  40x120x20

RETT. 0004534 P. 169,00

LAPP. RETT. 0004538 P. 179,00

LEAD



120x240

±6 mm

* 160x320 RETT. 0001752 M. 168,00

±7 mm

120x240 RETT. 0001760 M. 132,00

120x240 LAPP. RETT. 0002288 M. 149,00

120x120 RETT. 0001768 M. 102,00

120x120 LAPP. RETT. 0001784 M. 119,00

60x120 RETT. 0001772 M. 70,00

60x120 LAPP. RETT. 0002292 M. 80,00

10x60 RETT. 0002842 M. 57,50

X20 R11

±20 mm

60x120 RETT. 0001790 M. 99,00

Per la serie completa vedi pag.: 232
For the complete collection see at page: 232

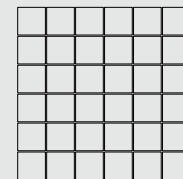

* Fino ad esaurimento scorte l'art. verrà consegnato a spessore 7 mm.
The item will be delivered 7 mm thick until stocks are exhausted.

30x30



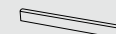

0002377 ±7 mm
MOSAICO LEAD RETT.
M. 104,00 

±7 mm

 **BATTISCOPA**  5,5x120

RETT. 0002328 P. 9,50

LAPP. RETT. 0002360 P. 12,50

 **GRADONE PLUS**  32x120x4,5x1,5

RETT. 0002332 P. 169,00

LAPP. RETT. 0002364 P. 179,00

 **ANGOLARE PLUS SX**  32x120x4,5x1,5

RETT. 0002336 P. 196,00

LAPP. RETT. 0002368 P. 206,00

 **ANGOLARE PLUS DX**  32x120x4,5x1,5

RETT. 0002340 P. 196,00

LAPP. RETT. 0002372 P. 206,00

 **GRADONE JOLLY**  40x120x20

RETT. 0004535 P. 169,00

LAPP. RETT. 0004539 P. 179,00



SHADE LEAD

120x240 RETT. 0002296 M. 149,00

120x120 RETT. 0002298 M. 119,00

60x120 RETT. 0002300 M. 80,00



SHADE ECRU

120x240 RETT. 0002295 M. 149,00

120x120 RETT. 0002297 M. 119,00

60x120 RETT. 0002299 M. 80,00



0,5x120 0000086 MATITA ALLUMINIO P. 20,90 

0,5x120 0000087 MATITA ALLUMINIO WHITE P. 34,90 

0,5x120 0000088 MATITA ALLUMINIO BLACK P. 34,90 

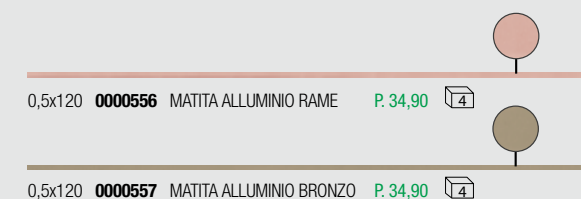

0,5x120 0000556 MATITA ALLUMINIO RAME P. 34,90 

0,5x120 0000557 MATITA ALLUMINIO BRONZO P. 34,90 

Articoli realizzati in alluminio per l'uso a parete, adatti a raccordare piastrelle di diverso spessore (9 mm / 7 mm).

Aluminium strip for use between wall tiles of different thicknesses (9 mm / 7 mm).

COMPOSIZIONI DECORATIVE DECORATIVE COMPOSITIONS

Con un occhio attento alla decorazione di interni, FLAVIKER propone composizioni grafiche realizzate a idrogetto sulle lastre ceramiche in 7 mm. Le fughe, se esaltate con stucchi a contrasto, diventano motivo decorativo. Questi soggetti sono disponibili nel formato 120x240 cm, oppure adattabili a qualsiasi misura richiesta con il servizio ON DEMAND. Il cliente dovrà fornire le esatte dimensioni della superficie da rivestire; verrà poi realizzato un disegno esecutivo con relativo preventivo. Ogni singolo pezzo che compone il soggetto verrà numerato in modo da facilitare le operazioni di posa. Fuga tra i diversi pezzi 2 mm.

With a keen eye for interior decoration, FLAVIKER offers design compositions created from waterjet-cut 7 mm thick ceramic slabs. Contrasting coloured grout can be used to enhance the joints and create a decorative pattern. These designs are available in 120x240 cm slabs or can be adapted to surfaces of any size using the ON DEMAND service. The customer will need to provide the exact dimensions of the surface to be tiled, after which a detailed drawing and quote can be made. Each piece making up the design will be numbered for ease of installation. A 2 mm joint will be maintained between the individual tiles.



PEBBLE
COMP. 120x240

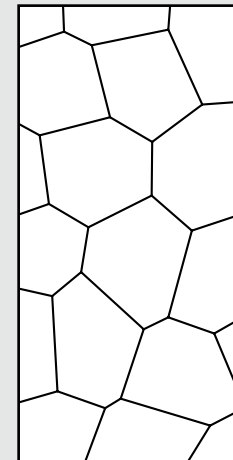

NATURALE NATURAL LAPPATO HONED

EARTH	0002311	0002323
LEAD	0002312	0002324
ECRU	0002310	0002322
MOON	0002309	0002321

CP. 1.749,00

TETRIS
COMP. 120x240

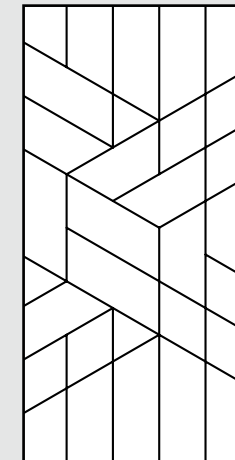

NATURALE NATURAL LAPPATO HONED

EARTH	0002307	0002319
LEAD	0002308	0002320
ECRU	0002306	0002318
MOON	0002305	0002317

CP. 1.749,00

THREE
COMP. 120x240

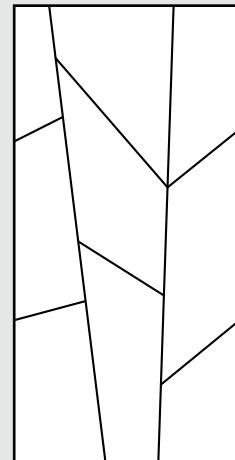

NATURALE NATURAL LAPPATO HONED

EARTH	0002303	0002315
LEAD	0002304	0002316
ECRU	0002302	0002314
MOON	0002301	0002313

CP. 1.749,00

COD. PER IL SERVIZIO SU MISURA ON DEMAND / ON DEMAND SERVICE CODE: 0002373 M. 739,00

Indicare le esatte dimensioni della parete da rivestire e i colori con cui realizzare la composizione.
Indicate the exact sizes of the wall to be tiled and the colours to use for the composition.

ESEMPI DI APPLICAZIONE EXAMPLES OF APPLICATION

COMP. 120X240

Consigliata per posa a pezzo singolo
Recommended for single-piece installation

Altezza soffitto 400 cm, Altezza posa 240 cm

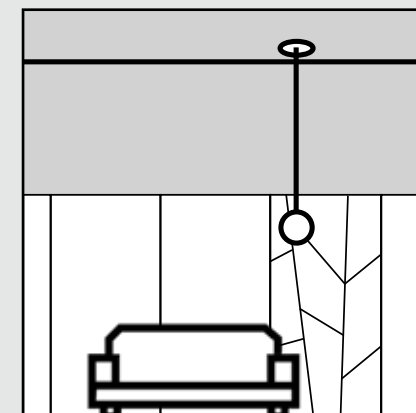

ON DEMAND

Es. Posa alt. 240 cm in tutta la parete
Ex. Laying 240 cm height throughout the length of the wall

Altezza soffitto 400 cm, Altezza posa 240 cm

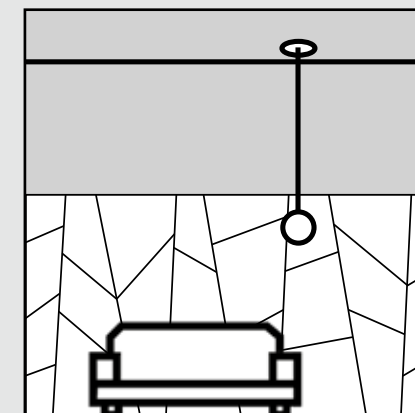

ON DEMAND

Es. Posa a tutta parete
Ex. Laying full height tiles

Altezza soffitto 400 cm, Altezza posa 400 cm

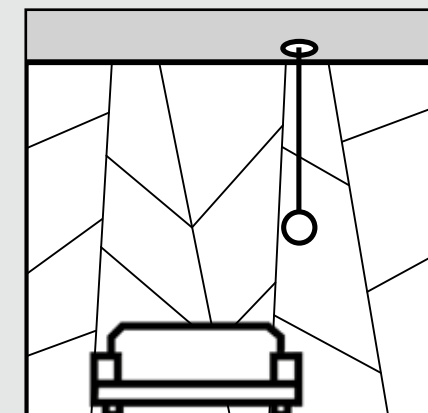

ESEMPIO DI REALIZZAZIONE ON DEMAND
EXAMPLE OF ON DEMAND SERVICE REALIZATION

RIVER PEBBLE ON DEMAND - ECRU / MOON / EARTH / LEAD
RIVER ECRU RETT. 120X240
RIVER LEAD RETT. 120X120

MOON





ECRU

EARTH

LEAD



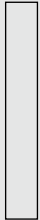







▼
9 mm
▲

60x60	30x60	10x60	30x30
			
0001773 RETT. M. 53,50 0002881 LAPP. M. 66,00	0003155 RETT. M. 48,00	0002382 RETT. M. 57,50	0002378 RETT. M. 66,00



Battiscopa RETT.
0002825 5,5x60 
P. 6,50

▼
9 mm
▲

60x60	30x60	10x60	30x30	60x60	30x60	10x60	30x30
							
0001775 RETT. M. 53,50 0002883 LAPP. M. 66,00	0003157 RETT. M. 48,00	0002384 RETT. M. 57,50	0002380 RETT. M. 66,00	0001776 RETT. M. 53,50 0002884 LAPP. M. 66,00	0003158 RETT. M. 48,00	0002385 RETT. M. 57,50	0002381 RETT. M. 66,00

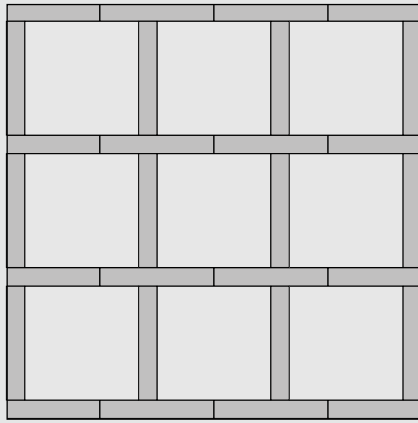

Battiscopa RETT.
0002827 5,5x60 
P. 6,50

1.1 2 colori

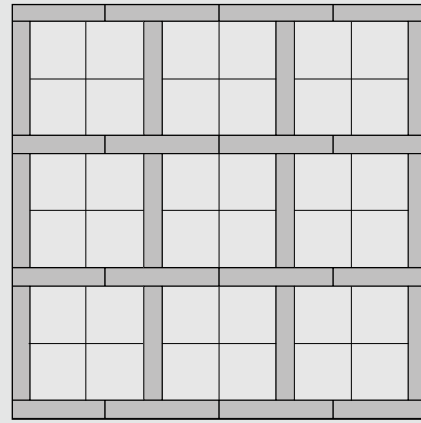

60X60 75%
10X60 25%

1.2 2 colori



30X30 75%
10X60 25%

1.3 3 colori

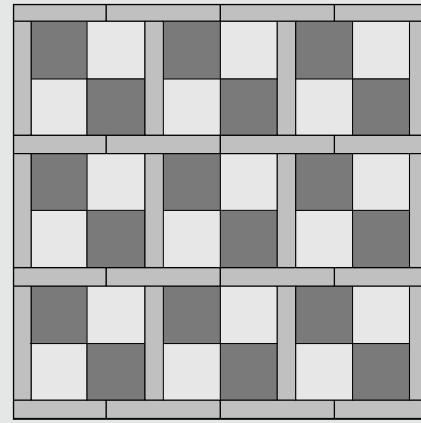

30X30 37.5%
30X30 37.5%
10X60 25%

2.1 2 colori

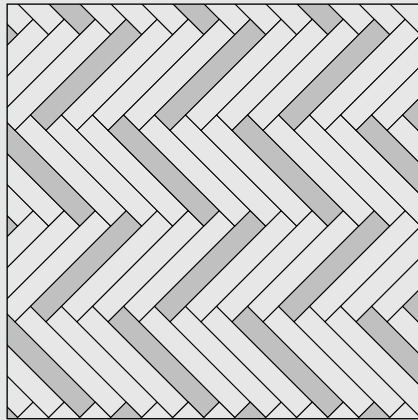

10X60 75%
10X60 25%

2.2 2 colori

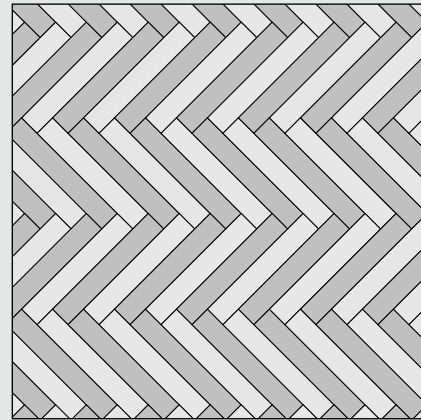

10X60 50%
10X60 50%

2.3 4 colori

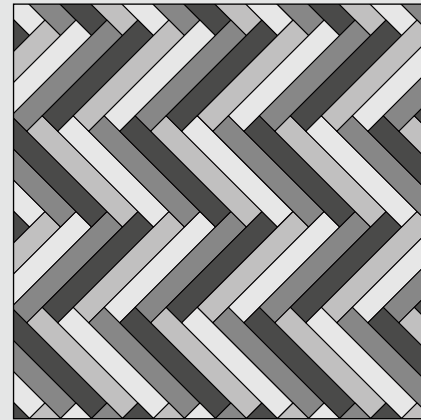

10X60 25% 10X60 25%
10X60 25% 10X60 25%

3.1 3 colori

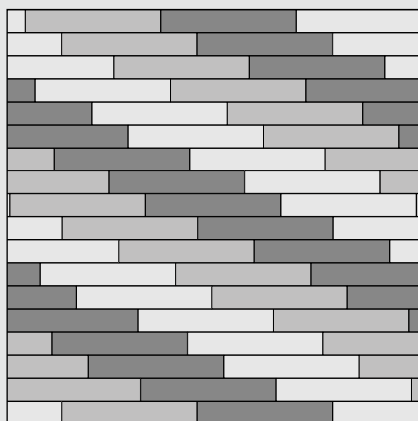

10X60 33.3% 10X60 33.3%
10X60 33.3%

4.1 2 colori

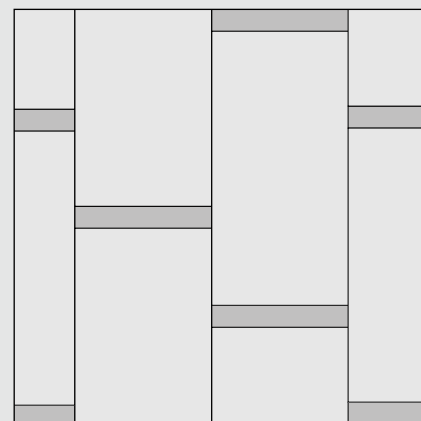

60X120 86%
10X60 14%

WIDE
SUPERSIZE SLABS

LASTRE IN GRES PORCELLANATO A MASSA COLORATA - CLASSIFICAZIONE SECONDO NORME EN 14411 (ISO 13006) ALLEGATO G GRUPPO B1a
FULL BODY COLORED PORCELAIN SLABS - CLASSIFICATION IN ACCORDANCE WITH EN 14411 (ISO 13006) ANNEX G GROUP B1a



F.to nominale Nominal size	F.to reale (mm) Work size (mm)	Spessore Thickness	Tipologia imballo Type of packing	Lastre/Imballo Slabs/Packing	Pz/Imballo Pcs/Packing	Mq/Scatola SqM/Box	Kg/Scatola Kg/Box	Scatole/Imballo Box/Packing	Mq totali SqM total	Kg/Imballo Kg/Packing	Kg totali Kg total	Prezzo imballo Packing Price
160x320 / 64"x128" rett.	1596,5x3195	6 mm	Cassa Crate	14	-	-	-	-	71,68	139	1.214	€ 130,00
			Cavalletto container Container Rack pallet	36	-	-	-	-	184,32	180	2.945	€ 235,00
120x240 / 48"x96" rett./lapp.	1194x2390	7mm	Cavalletto Rack pallet	40	-	-	-	-	115,20	100	2.116	€ 120,00
			Cassa Crate	20	-	-	-	-	57,60	100	1.108	€ 100,00
120x120 / 48"x48" rett./lapp.	1194x1194	7 mm	Cavalletto container Container Rack pallet	40	-	-	-	-	115,20	115	2.131	€ 190,00
			Pallet con sponde Pallet with sides	44	2	2,88	50,40	22	63,36	40	1.149	-
60x120 / 24"x48" rett./lapp.	596x1194	7 mm	Pallet	81	3	2,16	37,80	27	58,32	20	1.041	-
10x60 / 4"x24" rett.	97,6x596	7 mm	Pallet	680	17	1,02	17,85	40	40,80	15	929	-
60x60 / 24"x24" rett.	596x596	9 mm	Pallet	120	3	1,08	21,20	40	43,20	20	868	-
30x30 / 12"x12" rett.	297x297	9 mm	Pallet	576	12	1,08	21,20	48	51,84	-	1038	-
10x60 / 4"x24" rett.	97,6x596	9 mm	Pallet	768	16	0,96	19,00	48	46,08	-	930	-
60x120 / 24"x48" rett.	596x1195	20 mm	Pallet	30	1	0,72	32,65	30	21,60	20	1000	-

I pezzi speciali, per effetto delle lavorazioni, possono presentare variazioni di tonalità. Due to working process, special trims may show variations in tonality.
L'unità minima di vendita per tutti gli articoli (fondi, decori e pezzi speciali) è la scatola completa. The minimum sales quantity for all items (plain tiles, decorations and special trims) is one full box.
I dati relativi agli imballi sono aggiornati al momento della stampa del catalogo e pertanto possono subire variazioni nel corso del tempo.
Data referring to packaging have been update at time of printing; the actual data may be slightly different.
Approfondimenti sugli imballi a pag. 282 dell'area tecnica. Details concerning packaging available at page 282 inside technical area.

RIVER MULTIPLE SENSATIONS

WIDE
SUPERSIZE SLABS

MULTIPLE SENSATIONS è la materioteca di FLAVIKER, un contenitore di materie diverse sapientemente combinate insieme per dare vita ad atmosfere sorprendenti ed in linea con le principali tendenze del design contemporaneo.

MULTIPLE SENSATIONS from FLAVIKER is a collection of different materials which can be combined to create striking and original atmospheres in line with the latest trends in contemporary design.

RIVER

COZY

SUPREME

STILL NO_W

HANGAR



MOON



HAVANA

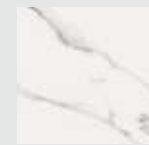

PURE STATUARIO

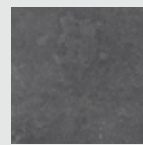

COAL



SMOKE



ECRU



BROWN

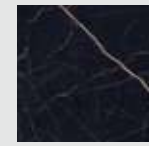

NOIR LAURENT

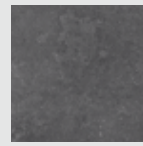

COAL



SMOKE



LEAD

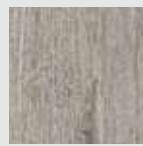

BARK

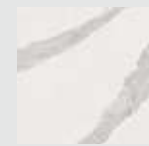

STATUARIO VENATO

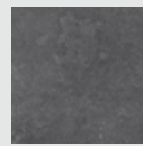

COAL



COAL



EARTH

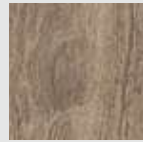

BROWN



CALACATTA EXTRA



SAND



ASH



RIVER EARTH
COZY BROWN



RIVER EARTH
WALL STONE BEIGE
HYPER TAUPE



RIVER LEAD
HANGAR COAL



RIVER MOON
COZY HAVANA

HANGAR

WIDE
SUPERSIZE SLABS

LASTRE IN GRES PORCELLANATO A MASSA COLORATA / FULL BODY COLORED PORCELAIN SLABS

SUPERFICI / SURFACES

Naturale
Natural

FORMATI / SIZES

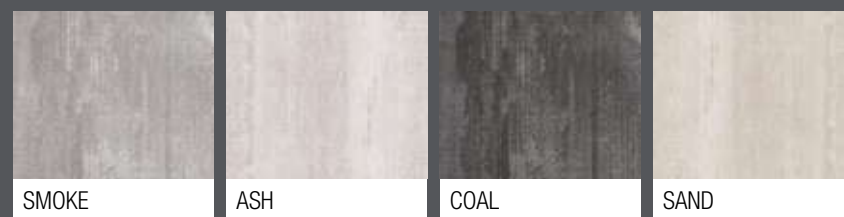
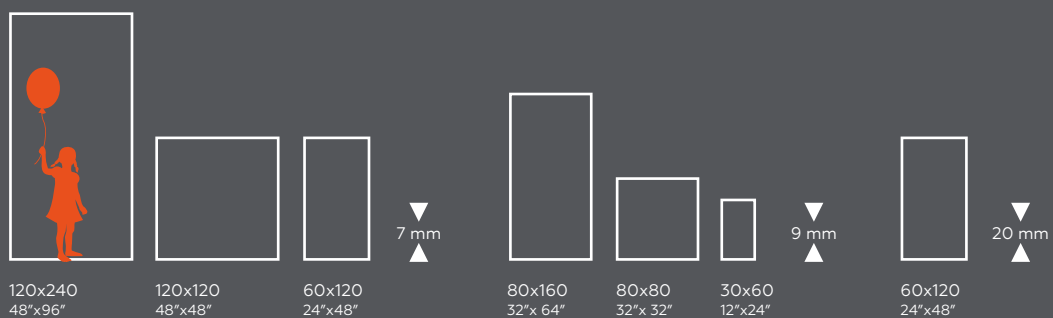

SMOKE 120X240, 120X120

HANGAR

WIDE
SUPERSIZE SLABS

LASTRE IN GRES PORCELLANATO A MASSA COLORATA
FULL BODY COLORED PORCELAIN SLABS



X20 COAL 60X120 20MM, ELEMENTO L



ASH 120X240, (COUNTERTOP ASH 120X240)

SMOKE

± 7 mm

120x240 RETT. **0000334** M. 132,00

120x120 RETT. **0000338** M. 102,00

60x120 RETT. **0001041** M. 70,00

± 9 mm

* **80x160** RETT. **0000326** M. 102,00

* **80x80** RETT. **0000330** M. 70,00

30x60 RETT. **0001045** M. 48,00

X20 R11 ± 20 mm

60x120 RETT. **0000951** M. 99,00

Per la serie completa vedi pag.: 234
For the complete collection see at page: 234

* Fino ad esaurimento scorte l'art. verrà consegnato a spessore 7 mm.
The item will be delivered 7 mm thick until stocks are exhausted.

34x26

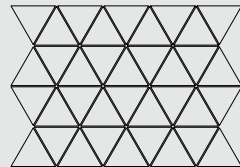



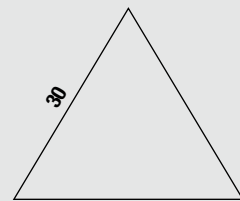







0001003
MOS. TRIANGOLI SMOKE RETT.
M. 349,00 

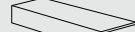

0000342
TRIANGOLO 30 SMOKE RETT.
M. 249,00  = 0,54 Mq

± 9 mm

	* BATTISCOPA 	5,5x80
	RETT. 0001165	P. 8,00
	GRADONE PLUS 	32x120x4,5x1,5
	RETT. 0001169	P. 169,00
	ANGOLARE PLUS SX 	32x120x4,5x1,5
	RETT. 0001173	P. 196,00
	ANGOLARE PLUS DX 	32x120x4,5x1,5
	RETT. 0001177	P. 196,00
	GRADONE JOLLY 	40x120x20
	RETT. 0004529	P. 169,00

120x240

ASH

± 7 mm

120x240 RETT. **0000333** M. 132,00

120x120 RETT. **0000337** M. 102,00

60x120 RETT. **0001040** M. 70,00

± 9 mm

* **80x160** RETT. **0000325** M. 102,00

* **80x80** RETT. **0000329** M. 70,00

30x60 RETT. **0001044** M. 48,00

* Fino ad esaurimento scorte l'art. verrà consegnato a spessore 7 mm.
The item will be delivered 7 mm thick until stocks are exhausted.

34x26

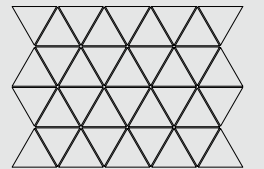



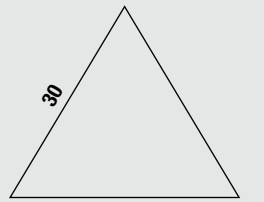







0001002
MOS. TRIANGOLI ASH RETT.
M. 349,00 



0000341
TRIANGOLO 30 ASH RETT.
M. 249,00  = 0,54 Mq

± 9 mm

	* BATTISCOPA 	5,5x80
	RETT. 0001164	P. 8,00
	GRADONE PLUS 	32x120x4,5x1,5
	RETT. 0001168	P. 169,00
	ANGOLARE PLUS SX 	32x120x4,5x1,5
	RETT. 0001172	P. 196,00
	ANGOLARE PLUS DX 	32x120x4,5x1,5
	RETT. 0001176	P. 196,00
	GRADONE JOLLY 	40x120x20
	RETT. 0004528	P. 169,00

120x240

COAL

± 7 mm

120x240 RETT. **0000335** M. 132,00

120x120 RETT. **0000339** M. 102,00

60x120 RETT. **0001042** M. 70,00

± 9 mm

* **80x160** RETT. **0000327** M. 102,00

* **80x80** RETT. **0000331** M. 70,00

30x60 RETT. **0001046** M. 48,00

X20 R11 ± 20 mm

60x120 RETT. **0000952** M. 99,00

Per la serie completa vedi pag.: 234
For the complete collection see at page: 234

* Fino ad esaurimento scorte l'art. verrà consegnato a spessore 7 mm.
The item will be delivered 7 mm thick until stocks are exhausted.

34x26

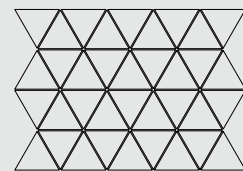



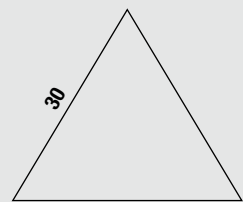





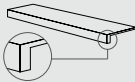

0001004
MOS. TRIANGOLI COAL RETT.
M. 349,00 



0000343
TRIANGOLO 30 COAL RETT.
M. 249,00  = 0,54 Mq

± 9 mm

	* BATTISCOPIA 	5,5x80
	RETT. 0001166	P. 8,00
	GRADONE PLUS 	32x120x4,5x1,5
	RETT. 0001170	P. 169,00
	ANGOLARE PLUS SX 	32x120x4,5x1,5
	RETT. 0001174	P. 196,00
	ANGOLARE PLUS DX 	32x120x4,5x1,5
	RETT. 0001178	P. 196,00
	GRADONE JOLLY 	40x120x20
	RETT. 0004530	P. 169,00

60x120

SAND

± 7 mm

120x240 RETT. **0000336** M. 132,00

120x120 RETT. **0000340** M. 102,00

60x120 RETT. **0001043** M. 70,00

± 9 mm

* **80x160** RETT. **0000328** M. 102,00

* **80x80** RETT. **0000332** M. 70,00

30x60 RETT. **0001047** M. 48,00

* Fino ad esaurimento scorte l'art. verrà consegnato a spessore 7 mm.
The item will be delivered 7 mm thick until stocks are exhausted.

34x26

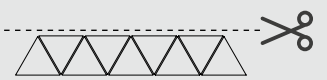
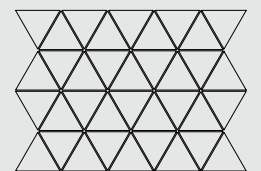



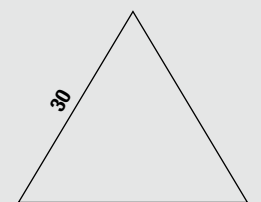





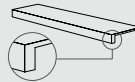

0001005
MOS. TRIANGOLI SAND RETT.
M. 349,00 

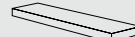

0000344
TRIANGOLO 30 SAND RETT.
M. 249,00  = 0,54 Mq

± 9 mm

	* BATTISCOPIA 	5,5x80
	RETT. 0001167	P. 8,00
	GRADONE PLUS 	32x120x4,5x1,5
	RETT. 0001171	P. 169,00
	ANGOLARE PLUS SX 	32x120x4,5x1,5
	RETT. 0001175	P. 196,00
	ANGOLARE PLUS DX 	32x120x4,5x1,5
	RETT. 0001179	P. 196,00
	GRADONE JOLLY 	40x120x20
	RETT. 0004531	P. 169,00

120x120

HANGAR

SCHEMI DI POSA INSTALLATION PATTERNS TRIANGOLO 30

O1.1 2 colori

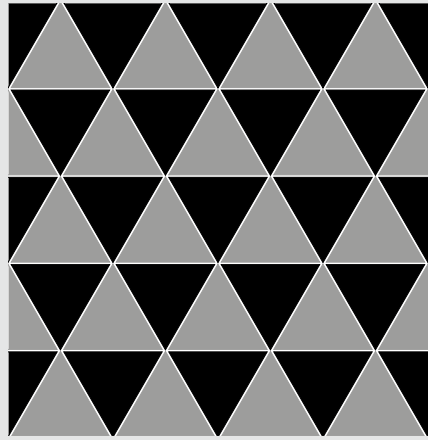

COLOR 1 50% ■
COLOR 2 50% ■

O1.2 2 colori

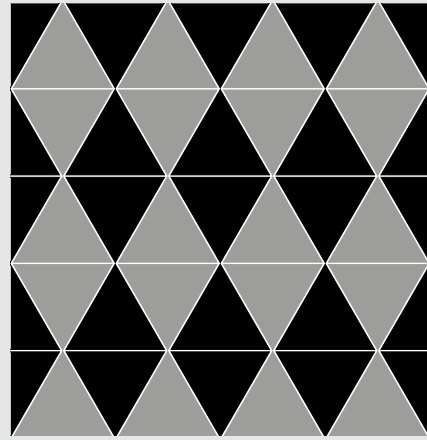

COLOR 1 50% ■
COLOR 2 50% ■

O1.3 2 colori

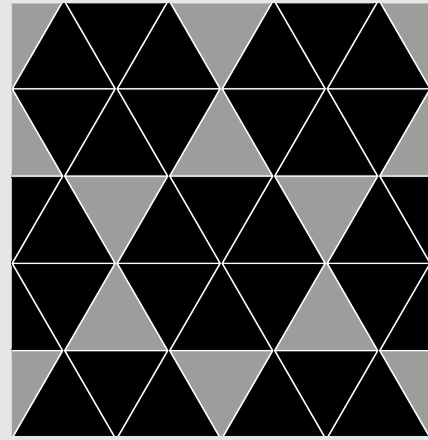

COLOR 1 75% ■
COLOR 2 25% ■

O1.4 2 colori

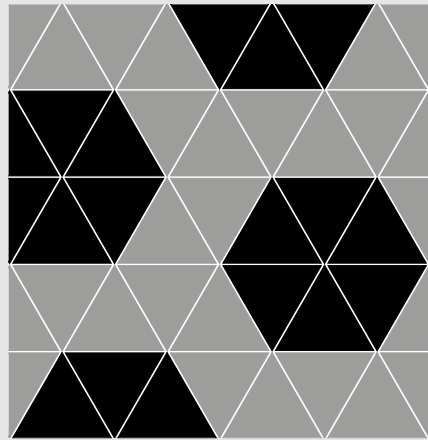

COLOR 1 57% ■
COLOR 2 43% ■

O1.5 3 colori

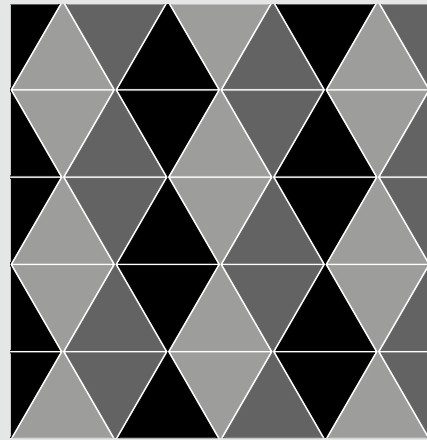

COLOR 1 33,33% ■ COLOR 3 33,33% ■
COLOR 2 33,33% ■

O1.6 3 colori

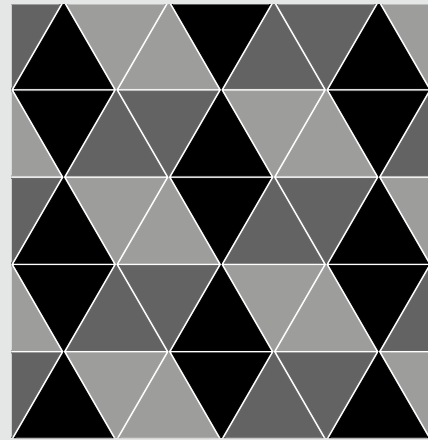

COLOR 1 33,33% ■ COLOR 3 33,33% ■
COLOR 2 33,33% ■

O1.7 3 colori

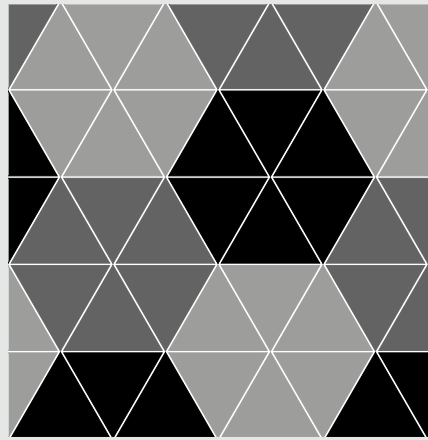

COLOR 1 33,33% ■ COLOR 3 33,33% ■
COLOR 2 33,33% ■

O1.8 4 colori

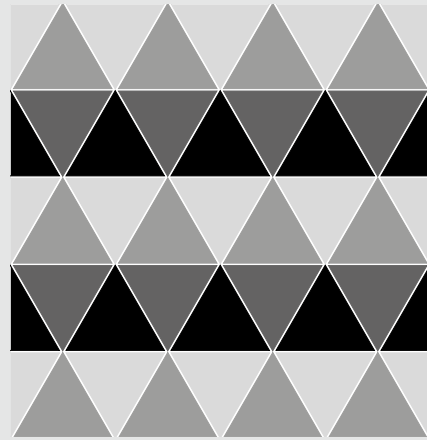

COLOR 1 25% ■ COLOR 3 25% ■
COLOR 2 25% ■ COLOR 4 25% ■

O2 2 colori

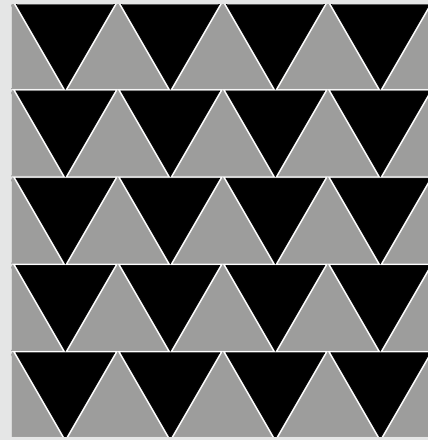

COLOR 1 50% ■
COLOR 2 50% ■



HANGAR TRIANGOLO 30 ASH



LASTRE IN GRES PORCELLANATO A MASSA COLORATA - CLASSIFICAZIONE SECONDO NORME EN 14411 (ISO 13006) ALLEGATO G GRUPPO B1a
FULL BODY COLORED PORCELAIN SLABS - CLASSIFICATION IN ACCORDANCE WITH EN 14411 (ISO 13006) ANNEX G GROUP B1a



F.to nominale Nominal size	F.to reale (mm) Work size (mm)	Spessore Thickness	Tipologia imballo Type of packing	Lastre/Imballo Slabs/Packing	Pz/Imballo Pcs/Packing	Mq/Scatola Sqm/Box	Kg/Scatola Kg/Box	Scatole/Imballo Box/Packing	Mq totali Sqm total	Kg/Imballo Kg/Packing	Kg totali Kg total	Prezzo imballo Packing Price
120x240 / 48"x96" rett.	1194x2390	7mm	Cavalletto Rack pallet	40	-	-	-	-	115,20	100	2.116	€ 120,00
			Cassa Crate	20	-	-	-	-	57,60	100	1.108	€ 100,00
			Cavalletto container Container Rack pallet	40	-	-	-	-	115,20	115	2.131	€ 190,00
120x120 / 48"x48" rett.	1194x1194	7 mm	Pallet con sponde Pallet with sides	44	2	2,88	50,40	22	63,36	40	1.149	-
80x160 / 32"x64" rett.	797,25x1596,5	9 mm	Cavalletto Rack pallet	44	2	2,56	50,00	22	56,32	70	1.170	€ 50,00
60x120 / 24"x48" rett.	596x1194	7 mm	Pallet	81	3	2,16	37,80	27	58,32	20	1.041	-
80x80 / 32"x32" rett.	797,25x797,25	9 mm	Pallet	88	2	1,28	25,00	44	56,32	20	1.120	-
30x60 / 12"x24" rett.	297x596	9 mm	Pallet	240	6	1,08	21,20	40	43,20	20	868	-
60x120 / 24"x48" rett.	600x1200	20 mm	Pallet	27	1	0,72	34,36	27	19,44	20	943	-

I pezzi speciali, per effetto delle lavorazioni, possono presentare variazioni di tonalità. Due to working process, special trims may show variations in tonality.
L'unità minima di vendita per tutti gli articoli (fondi, decori e pezzi speciali) è la scatola completa. The minimum sales quantity for all items (plain tiles, decorations and special trims) is one full box.
I dati relativi agli imballi sono aggiornati al momento della stampa del catalogo e pertanto possono subire variazioni nel corso del tempo.
Data referring to packaging have been update at time of printing; the actual data may be slightly different.
Approfondimenti sugli imballi a pag. 282 dell'area tecnica. Details concerning packaging available at page 282 inside technical area.

HANGAR MULTIPLE SENSATIONS

WIDE
SUPERSIZE SLABS

MULTIPLE SENSATIONS è la materioteca di FLAVIKER, un contenitore di materie diverse sapientemente combinate insieme per dare vita ad atmosfere sorprendenti ed in linea con le principali tendenze del design contemporaneo.

MULTIPLE SENSATIONS from FLAVIKER is a collection of different materials which can be combined to create striking and original atmospheres in line with the latest trends in contemporary design.

HANGAR

HYPER

RIVER

STILL NO_W

SUPREME

COZY



SMOKE

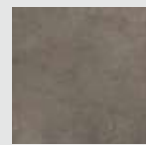

TAUPE



ECRU

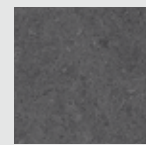

COAL

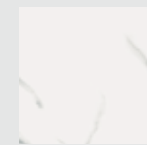

PURE STATUARIO



HAVANA



ASH



GREY



EARTH



GRAY

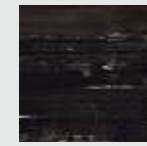

BLACK DELUXE



DESERT



COAL

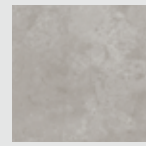

SILVER



LEAD



GRAY



STATUARIO VENATO



BARK



SAND

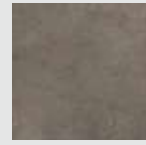

TAUPE



EARTH



SAND



CALACATTA EXTRA



BROWN

HANGAR SMOKE
SUPREME PURE STATUARIO LUX*, BLACK DELUXE LUX*



HANGAR ASH
COZY DESERT



HANGAR ASH, COAL, SMOKE, COAL
STILL NO_W GRAY



HANGAR SAND
STILL NO_W SAND

BACKSTAGE

GRES PORCELLANATO A MASSA COLORATA / FULL BODY COLORED PORCELAIN TILES

SUPERFICI / SURFACES



Naturale
Natural

FORMATI / SIZES

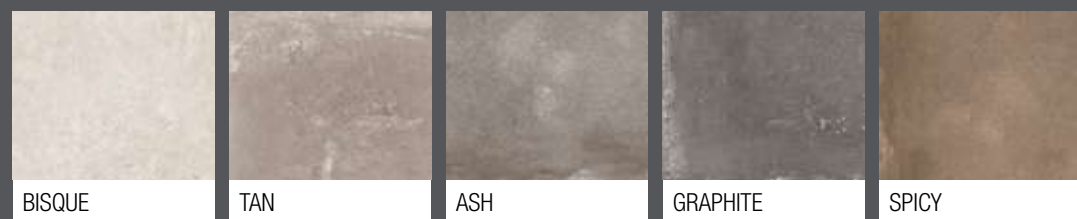
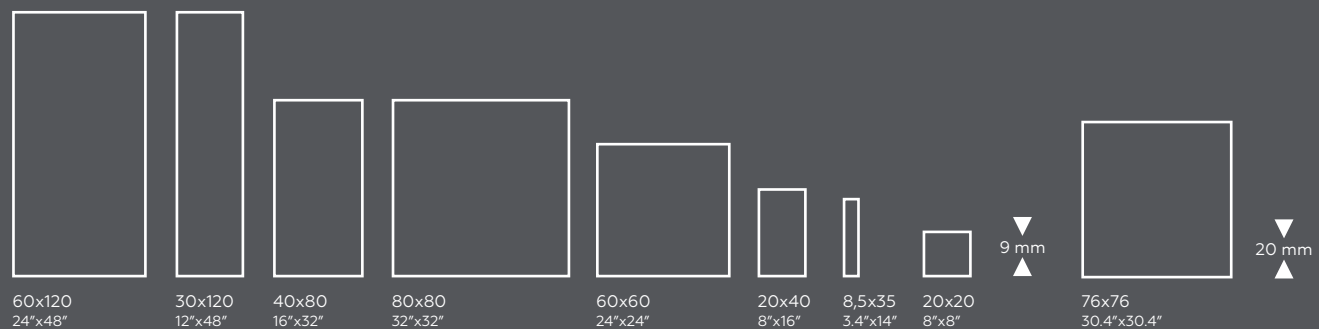

DAKOTA NATURALE RETT. 20X120
TAN RETT. 60X120





60x60

R: Rettificato | Rectified

60x120 MIX FLOOR



Pcs/Box

- 60x120 
- 60x80 
- 60x40 

BK FLO 44 MIX FLOOR RETT. M. 82,00 

30x30

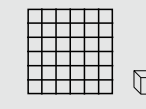

BK MO 441
MOSAICO M. 104,00 

51x29,2



BK ES 44 R
MOS. HEXAGON M. 120,00 

60x120

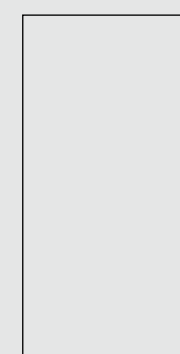

BK 6144 R
M. 70,00

30x120

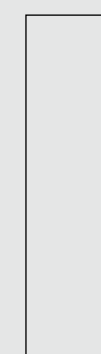

BK 3144 R
M. 70,00

40x80



BK 4844 R
M. 53,50

40x80 MIX SIZES RETT.

3 pz 3 pz 3 pz
20x80 - 13,5x80 - 6,5x80





BK MIX 44
M. 78,00

60x60

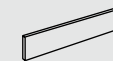

BK 6044 R
M. 53,50



Battiscopa 5,5x60
BK BN 446
P. 6,50 



Gradone Plus 32x120x4,5x2
BK RT 442
P. 169,00 



Angolare Plus sx 32x120x4,5x2
BK RA 44S
Angolare Plus dx 32x120x4,5x2
BK RA 44D
P. 196,00 

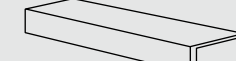

Gradone Jolly 40x120x20
0004544
P. 169,00 



R: Rettificato | Rectified

R: Rettificato | Rectified

60x120 MIX FLOOR

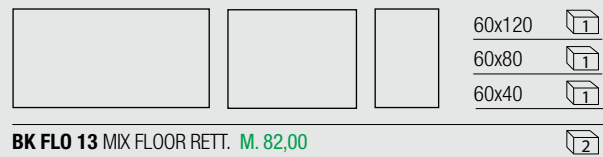

BK FLO 13 MIX FLOOR RETT. M. 82,00

30x30

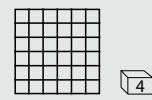

BK MO 131
MOSAICO M. 104,00

51x29,2



BK ES 13 R
MOS. HEXAGON M. 120,00

60x120 MIX FLOOR

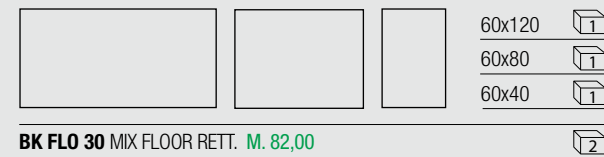

BK FLO 30 MIX FLOOR RETT. M. 82,00

30x30

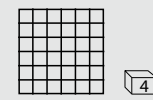

BK MO 301
MOSAICO M. 104,00

51x29,2



BK ES 30 R
MOS. HEXAGON M. 120,00

60x120

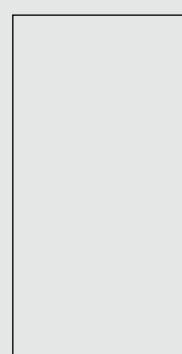

BK 6113 R
M. 70,00

30x120



BK 3113 R
M. 70,00

40x80



BK 4813 R
M. 53,50

40x80 MIX SIZES RETT.

3 pz 3 pz 3 pz
20x80 - 13,5x80 - 6,5x80



BK MIX 13
M. 78,00

60x60

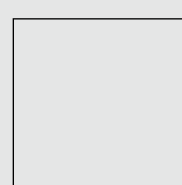

BK 6013 R
M. 53,50

8,5x35
RESIZE

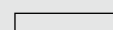

0000139
M. 53,50

GRES PORCELLANATO
PORCELAIN TILES



Battiscopa 5,5x60
BK BN 136
P. 6,50



Gradone Plus 32x120x4,5x2
BK RT 132
P. 169,00



Angolare Plus sx 32x120x4,5x2
BK RA 13S
Angolare Plus dx 32x120x4,5x2
BK RA 13D
P. 196,00



Gradone Jolly 40x120x20
0004540
P. 169,00

60x120

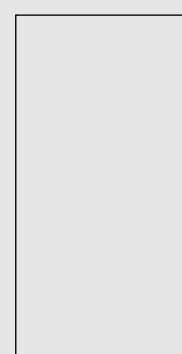

BK 6130 R
M. 70,00

30x120



BK 3130 R
M. 70,00

80x80



0003048
M. 70,00

40x80



BK 4830 R
M. 53,50

40x80 MIX SIZES RETT.

3 pz 3 pz 3 pz
20x80 - 13,5x80 - 6,5x80



BK MIX 30
M. 78,00

60x60

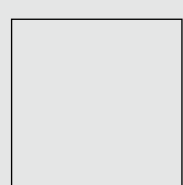

BK 6030 R
M. 53,50



Battiscopa 5,5x60
BK BN 306
P. 6,50



Gradone Plus 32x120x4,5x2
BK RT 302
P. 169,00



Angolare Plus sx 32x120x4,5x2
BK RA 30S
Angolare Plus dx 32x120x4,5x2
BK RA 30D
P. 196,00

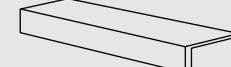

Gradone Jolly 40x120x20
0004542
P. 169,00



60x60



60x60

R: Rettificato | Rectified

*Per la serie completa vedi pag. 236 | For the complete collection see page 236

*Per la serie completa vedi pag. 236 | For the complete collection see page 236

R: Rettificato | Rectified

60x120 MIX FLOOR

Pcs/Box
60x120 1
60x80 1
60x40 1

BK FLO 22 MIX FLOOR RETT. M. 82,00 2

30x30

BK MO 221
MOSAICO M. 104,00 4

51x29,2

BK ES 22 R
MOS. HEXAGON M. 120,00 4

60x120 MIX FLOOR

Pcs/Box
60x120 1
60x80 1
60x40 1

BK FLO 23 MIX FLOOR RETT. M. 82,00 2

30x30

BK MO 231
MOSAICO M. 104,00 4

51x29,2

BK ES 23 R
MOS. HEXAGON M. 120,00 4

60x120 **30x120**

80x80 **40x80**

40x80 MIX SIZES RETT.
3 pz 3 pz 3 pz
20x80 - 13,5x80 - 6,5x80

60x60

8,5x35 RESIZE

BK 6122 R M. 70,00
BK 3122 R M. 70,00
0003047 M. 70,00
BK 4822 R M. 53,50
BK MIX 22 M. 78,00
BK 6022 R M. 53,50
0000138 M. 53,50

GRES PORCELLANATO
PORCELAIN TILES

60x120 **30x120**

80x80 **40x80**

40x80 MIX SIZES RETT.
3 pz 3 pz 3 pz
20x80 - 13,5x80 - 6,5x80

60x60

BK 6123 R M. 70,00
BK 3123 R M. 70,00
0003049 M. 70,00
BK 4823 R M. 53,50
BK MIX 23 M. 78,00
BK 6023 R M. 53,50

Battiscopa 5,5x60
BK BN 226 P. 6,50 10

Gradone Plus 32x120x4,5x2
BK RT 222 P. 169,00 1

Angolare Plus sx 32x120x4,5x2
BK RA 22S
Angolare Plus dx 32x120x4,5x2
BK RA 22D P. 196,00 1

Gradone Jolly 40x120x20
0004541 P. 169,00 1

Battiscopa 5,5x60
BK BN 236 P. 6,50 10

Gradone Plus 32x120x4,5x2
BK RT 232 P. 169,00 1

Angolare Plus sx 32x120x4,5x2
BK RA 23S
Angolare Plus dx 32x120x4,5x2
BK RA 23D P. 196,00 1

Gradone Jolly 40x120x20
0004543 P. 169,00 1

BACKSTAGE

GRES PORCELLANATO A MASSA COLORATA
FULL BODY COLORED PORCELAIN TILES

CONTEMPORARY

ASH AKE



40x80

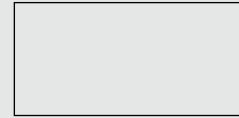

BK 4822 D
M. 66,00

40x80

D: Fondo Decorato Rettificato | Rectified Decorated Base File

DECORI / DECORS



40x80
BK 4844 F HEXAGONE
HOLE SPICY RETT. P. 33,00



40x80
BK 4813 F HEXAGONE
HOLE BISQUE RETT. P. 33,00



40x80
BK 4823 F HEXAGONE
HOLE GRAPHITE RETT. P. 33,00



60x60
BK 6044 F HEXAGONE
HOLE SPICY RETT. P. 33,00

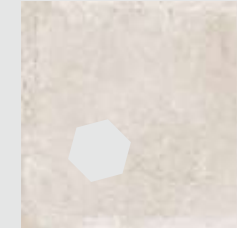

60x60
BK 6013 F HEXAGONE
HOLE BISQUE RETT. P. 33,00

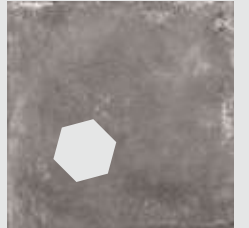

60x60
BK 6023 F HEXAGONE
HOLE GRAPHITE RETT. P. 33,00



40x80
BK 4830 F HEXAGONE
HOLE TAN RETT. P. 33,00



40x80
BK 4822 F HEXAGONE
HOLE ASH RETT. P. 33,00

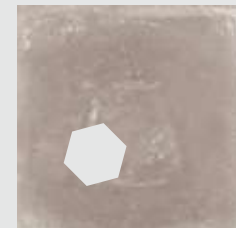

60x60
BK 6030 F HEXAGONE
HOLE TAN RETT. P. 33,00



60x60
BK 6022 F HEXAGONE
HOLE ASH RETT. P. 33,00



8,5x8,5
BK DE 222 HEXAGON
COLOR MIX4 RETT. P. 18,50



8,5x8,5
BK DE 232 HEXAGON
TEXTURE MIX4 RETT. P. 18,50

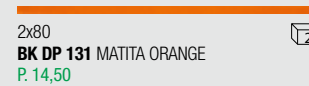

2x80
BK DP 131 MATITA ORANGE
P. 14,50



40x80
BK DI 131 DECORO
BISQUE ORANGE RETT. P. 76,00

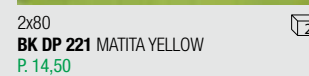

2x80
BK DP 221 MATITA YELLOW
P. 14,50



40x80
BK DI 221 DECORO
ASH YELLOW RETT. P. 76,00



BACKSTAGE ASH AKE RETT. 40X80
BACKSTAGE GRAPHITE RETT. 40X80

OUTDOOR (R11) 9 mm



20x40
BK 2430
TAN STRUTTURATO NAT.
M. 33,50



20x40
BK 2422
ASH STRUTTURATO NAT.
M. 33,50



20x20
BK 2030
TAN STRUTTURATO NAT.
M. 33,50



20x20
BK 2022
ASH STRUTTURATO NAT.
M. 33,50

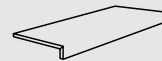

15x30x3,5
BK EN 303 ELEMENTO ELLE
MONOLITICO STRUTTURATO TAN
P. 17,50

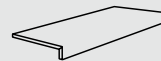

15x30x3,5
BK EN 223 ELEMENTO ELLE
MONOLITICO STRUTTURATO ASH
P. 17,50

X20 (R11) 20 mm

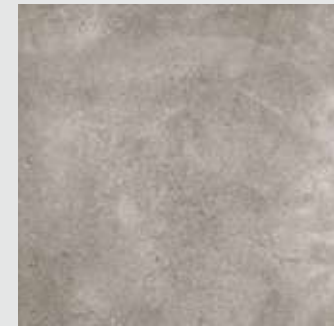

76x76
BK 7622 M
BACKSTAGE ASH 20 MM NAT.
M. 99,00



76x76
BK 7623 M
BACKSTAGE GRAPHITE 20 MM NAT.
M. 99,00

Per la serie completa vedi pag. 236
For the complete collection see page 236

MIX FLOOR SCHEMI DI POSA / INSTALLATION PATTERNS

1

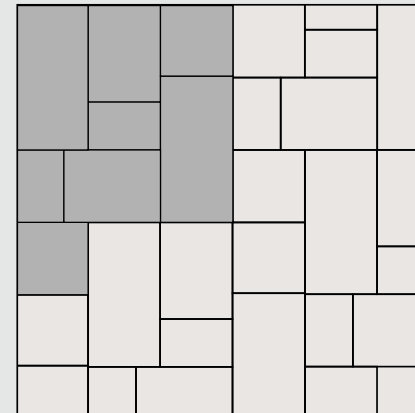

60x120 MIX FLOOR 80%
60x60 20%

2

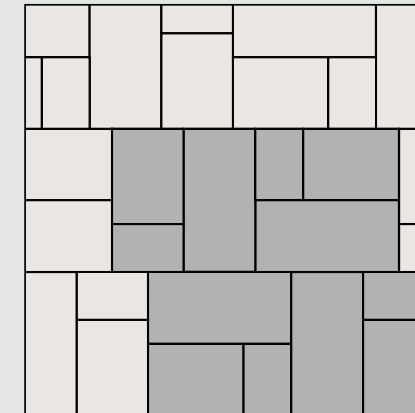

60x120 MIX FLOOR 100%

3

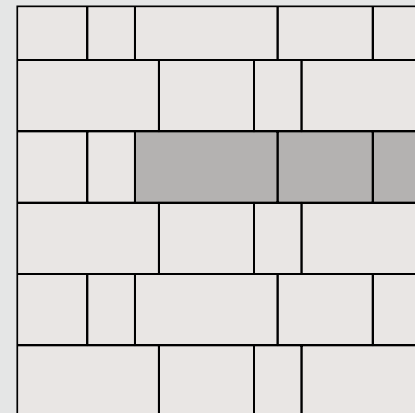

60x120 MIX FLOOR 100%

4

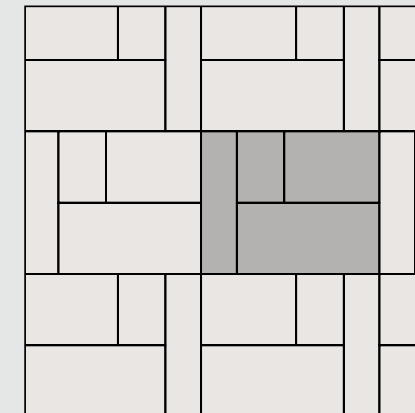

60x120 MIX FLOOR 80%
30x120 20%

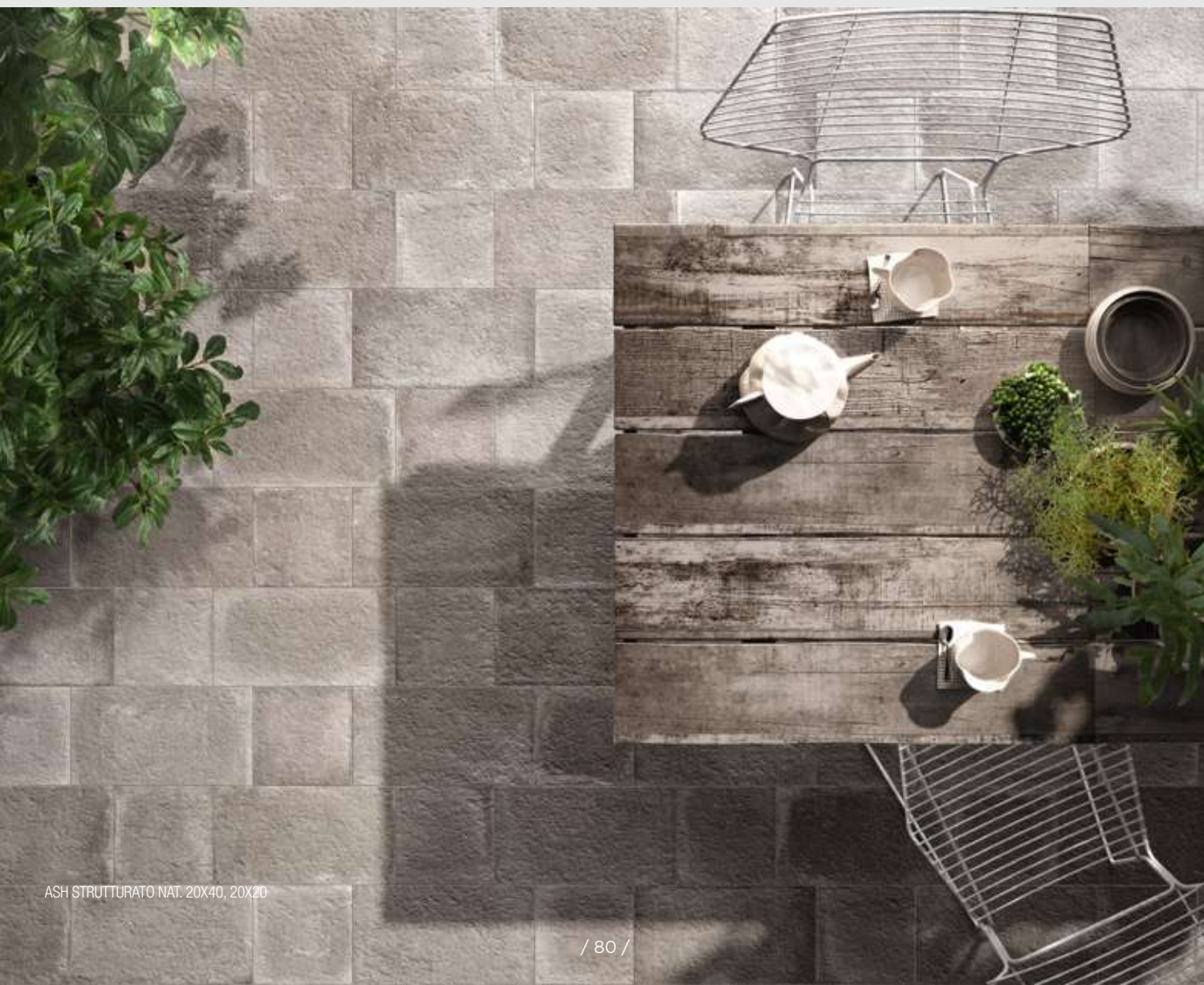

GRES PORCELLANATO A MASSA COLORATA - CLASSIFICAZIONE SECONDO NORME EN 14411 (ISO 13006) ALLEGATO G GRUPPO BIa
FULL BODY COLORED PORCELAIN TILES - CLASSIFICATION IN ACCORDANCE WITH EN 14411 (ISO 13006) ANNEX G GROUP BIa

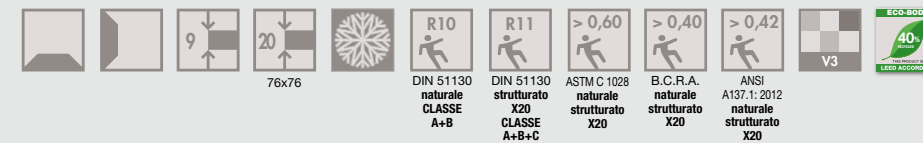

F.to nominale Nominal size	F.to reale (mm) Work size (mm)	Spessore Thickness	Tipologia imballo Type of packing	Lastre/Imballo Slabs/Packing	Pz/Imballo Pcs/Packing	Mq/Scatola Sqm/Box	Kg/Scatola Kg/Box	Scatole/Imballo Box/Packing	Mq totali Sqm total	Kg/Imballo Kg/Packing	Kg totali Kg total	Prezzo imballo Packing Price
60x120 / 24"x48" rett.	596x1194	9	Pallet	60	2	1,44	28,00	30	43,20	20	860	-
60x120 / 24"x48" MIX FLOOR	-	9	Pallet	52	2	1,44	28,00	26	37,44	20	748	-
30x120 / 12"x48" rett.	297x1194	9	Pallet	144	4	1,44	28,00	36	51,84	20	1.028	-
40x80 / 16"x32" rett.	400x800	9	Pallet	90	3	0,96	19,00	30	28,80	20	590	-
60x60 / 24"x24" rett.	596x596	9	Pallet	120	3	1,08	21,20	40	43,20	20	868	-
20x40 / 8"x16" strut.nat.	-	9	Pallet	960	15	1,20	21,00	64	76,80	20	1.364	-
8,5x35 / 3.4"x14"	-	9	Pallet	1680	20	0,602	12,50	84	50,57	20	1.065	-
20x20 / 8"x8" strut.nat.	-	9	Pallet	1920	30	1,20	21,00	64	76,80	20	1.364	-
76x76 / 30.4"x30.4" nat.	-	20	Pallet	45	1	0,58	29,73	45	26,10	20	1.353	-
80x80 / 32"x32" rett.	797,25x797,25	9	Pallet	88	2	1,28	25,00	44	56,32	20	1.120	-

I pezzi speciali, per effetto delle lavorazioni, possono presentare variazioni di tonalità. Due to working process, special trims may show variations in tonality.
L'unità minima di vendita per tutti gli articoli (fondi, decori e pezzi speciali) è la scatola completa. The minimum sales quantity for all items (plain tiles, decorations and special trims) is one full box.
I dati relativi agli imballi sono aggiornati al momento della stampa del catalogo e pertanto possono subire variazioni nel corso del tempo.
Data referring to packaging have been update at time of printing; the actual data may be slightly different.
Approfondimenti sugli imballi a pag. 282 dell'area tecnica. Details concerning packaging available at page 282 inside technical area.

URBAN CONCRETE

GRES PORCELLANATO A MASSA COLORATA / FULL BODY COLORED PORCELAIN TILES

SUPERFICI / SURFACES



Naturale
Natural



Strutturato
Textured

FORMATI / SIZES



40x80
16"x32"



60x60
24"x24"



30x60
12"x24"



9 mm



80x80
32"x32"



11 mm



WHITE

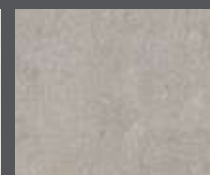

FOG

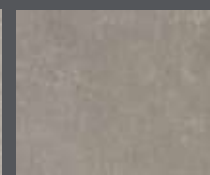

SMOKE



NIGHT

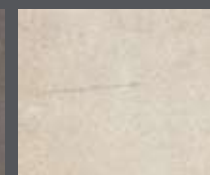

GREIGE



NUT



30X60 WHITE FRAME RETT.
60X60 SMOKE RETT.

URBAN CONCRETE

GRES PORCELLANATO A MASSA COLORATA
FULL BODY COLORED PORCELAIN TILES



30X60 SMOKE FRAME RETT.
30X60 NIGHT RETT.



40X80 GREIGE RETT.



60x60

R: Rettificato | Rectified



60x60

R: Rettificato | Rectified

40x80

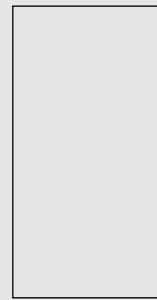

UC 4810 R M. 53,50

60x60



UC 6010 M. 48,00
UC 6010 R M. 53,50

30x60



UC 3610 R M. 48,00

30x60 MIX SIZES RETT.

6 pz 6 pz 6 pz
5x60 - 10x60 - 15x60



UC MIX 10 M. 78,00

30x30

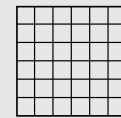

UC MO 101
MOSAICO
M. 104,00 



Battiscopa Rettificato
UC BN 106 5,5x60 P. 6,50 

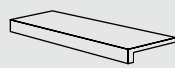

Gradone Plus 33x60x4,5x2
UC RT 106 A P. 80,00 

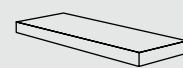

Angolare Plus sx 33x60x4,5x2
UC RA 10S
Angolare Plus dx 33x60x4,5x2
UC RA 10D
P. 106,00 

80x80



UC 8040 R

M. 65,00

40x80



UC 4840 R M. 53,50

60x60



UC 6040 M. 48,00
UC 6040 R M. 53,50

30x60



UC 3640 R M. 48,00

30x60 MIX SIZES RETT.

6 pz 6 pz 6 pz
5x60 - 10x60 - 15x60



UC MIX 40 M. 78,00

30x30

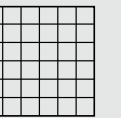

UC MO 401
MOSAICO
M. 104,00 

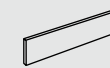

Battiscopa Rettificato
UC BN 409 5,5x80 P. 8,00 
UC BN 406 5,5x60 P. 6,50 

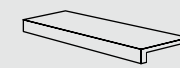

Gradone Plus 33x60x4,5x2
UC RT 406 A P. 80,00 

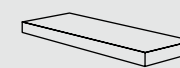

Angolare Plus sx 33x60x4,5x2
UC RA 40S
Angolare Plus dx 33x60x4,5x2
UC RA 40D
P. 106,00 

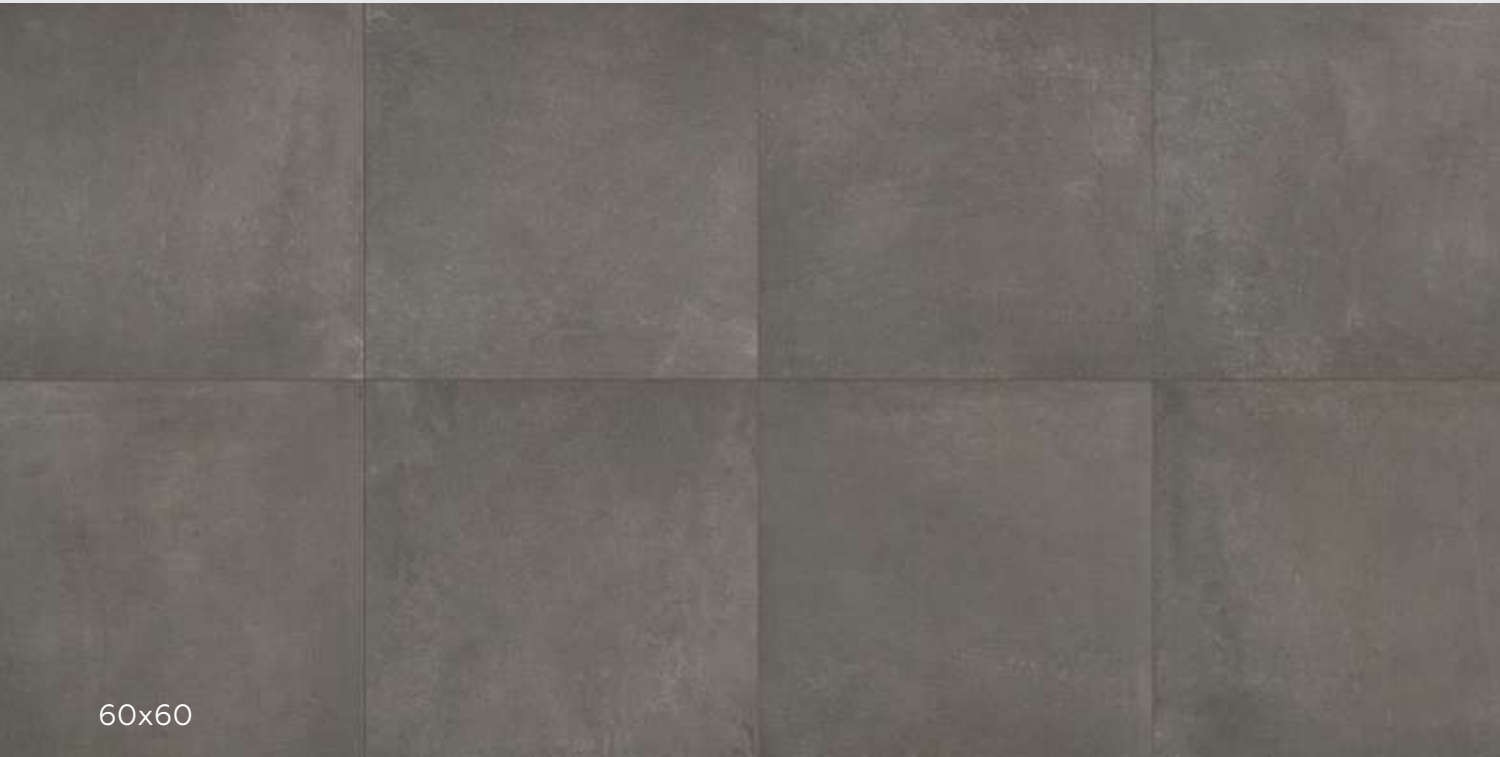

60x60



60x60

R: Rettificato | Rectified
T: Strutturato non Rettificato | Textured not Rectified

R: Rettificato | Rectified
T: Strutturato non Rettificato | Textured not Rectified

80x80 **40x80** **60x60** **30x60** **30x60 MIX SIZES RETT.** **30x30**

6 pz 6 pz 6 pz
5x60 - 10x60 - 15x60

UC 8090 R M. 65,00 **UC 4890 R** M. 53,50 **UC 6090** M. 48,00 **UC 3690** M. 41,00 **UC MIX 90** M. 78,00 **UC MO 901** M. 104,00

UC 6090 R M. 53,50 **UC 3690 R** M. 48,00 **UC 3690 T** M. 41,00 **MOSAICO**

80x80 **40x80** **60x60** **30x60** **30x60 MIX SIZES RETT.** **30x30**

6 pz 6 pz 6 pz
5x60 - 10x60 - 15x60

UC 8022 R M. 65,00 **UC 4822 R** M. 53,50 **UC 6022** M. 48,00 **UC 3622** M. 41,00 **UC MIX 22** M. 78,00 **UC MO 221** M. 104,00

UC 6022 R M. 53,50 **UC 3622 R** M. 48,00 **UC 3622 T** M. 41,00 **MOSAICO**

Battiscopa Rettificato
UC BN 909 5,5x80 P. 8,00 **UC BN 906** 5,5x60 P. 6,50

Gradone Plus 33x60x4,5x2
UC RT 906 A P. 80,00

Angolare Plus sx 33x60x4,5x2
UC RA 90S
Angolare Plus dx 33x60x4,5x2
UC RA 90D
P. 106,00

Battiscopa Rettificato
UC BN 229 5,5x80 P. 8,00 **UC BN 226** 5,5x60 P. 6,50

Gradone Plus 33x60x4,5x2
UC RT 226 A P. 80,00

Angolare Plus sx 33x60x4,5x2
UC RA 22S
Angolare Plus dx 33x60x4,5x2
UC RA 22D
P. 106,00



60x60

60x60

R: Rettificato | Rectified
T: Strutturato non Rettificato | Textured not Rectified

R: Rettificato | Rectified
T: Strutturato non Rettificato | Textured not Rectified

80x80 **40x80** **60x60** **30x60** **30x60 MIX SIZES RETT.** **30x30**

6 pz 6 pz 6 pz
5x60 - 10x60 - 15x60

UC 8030 R M. 65,00 **UC 4830 R** M. 53,50 **UC 6030** M. 48,00 **UC 3630** M. 41,00 **UC MIX 30** M. 78,00 **UC MO 301** M. 104,00

UC 6030 R M. 53,50 **UC 3630 R** M. 48,00 **UC 3630 T** M. 41,00 **MOSAICO**

40x80 **60x60** **30x60** **30x60 MIX SIZES RETT.** **30x30**

6 pz 6 pz 6 pz
5x60 - 10x60 - 15x60

UC 4844 R M. 53,50 **UC 6044** M. 48,00 **UC 3644 R** M. 48,00 **UC MIX 44** M. 78,00 **UC MO 441** M. 104,00

UC 6044 R M. 53,50 **MOSAICO**

Battiscopa Rettificato
UC BN 309 5,5x80 P. 8,00 **UC BN 306** 5,5x60 P. 6,50

Gradone Plus 33x60x4,5x2
UC RT 306 A P. 80,00

Angolare Plus sx 33x60x4,5x2
UC RA 30S
Angolare Plus dx 33x60x4,5x2
UC RA 30D
P. 106,00

Elle Monolitico Struttura 15x30x3,5
UC EN 303 P. 17,50

Battiscopa Rettificato
UC BN 446 5,5x60 P. 6,50

Gradone Plus 33x60x4,5x2
UC RT 446 A P. 80,00

Angolare Plus sx 33x60x4,5x2
UC RA 44S
Angolare Plus dx 33x60x4,5x2
UC RA 44D
P. 106,00



30x60
UC 3610 S WHITE FRAME RETT. M. 48,00



30x40
UC MO 402 MOSAICO MIX WHITE/FOG RETT. P. 18,00

S: Rettificato | Rectified



30x60
UC 3622 S SMOKE FRAME RETT. M. 48,00



30x40
UC MO 902 MOSAICO MIX SMOKE/NIGHT RETT. P. 18,00



30x60
UC 3630 S GREIGE FRAME RETT. M. 48,00



30x40
UC MO 442 MOSAICO MIX GREIGE/NUT RETT. P. 18,00



30x60
UC DI 102 FASCIA GRAFFITI RETT. (mix 2 soggetti) P. 56,00



15x60
UC DF 102 LISTONE GRAFFITI RETT. (mix 4 soggetti) P. 37,00



DECORI / DECORS



UC DP 005
BACCHETTA METAL 1,5x60
P. 17,50



UC DP 006
BACCHETTA METAL 1,5x80
P. 21,00



15x60
UC DF 101 LISTONE PATCHWORK RETT. (mix 6 soggetti) P. 37,00



20x80
CY DF 281 DEC. PATTERN Mix 2pz
P. 54,00



GRES PORCELLANATO A MASSA COLORATA - CLASSIFICAZIONE SECONDO NORME EN 14411 (ISO 13006) ALLEGATO G GRUPPO BIa
FULL BODY COLORED PORCELAIN STONEWARE - CLASSIFICATION IN ACCORDANCE WITH EN 14411 (ISO 13006) ANNEX G GROUP BIa

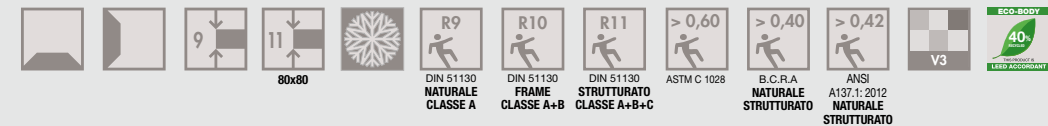

F.to nominale Nominal size	F.to reale (mm) Work size (mm)	Spessore Thickness	Tipologia imballo Type of packing	Lastre/Imballo Slabs/Packing	Pz/Imballo Pcs/Packing	Mq/Scatola Sqm/Box	Kg/Scatola Kg/Box	Scatole/Imballo Box/Packing	Mq totali Sqm total	Kg/Imballo Kg/Packing	Kg totali Kg total	Prezzo imballo Packing Price
80x80 / 32"x32" rett.	800x800	11	Pallet	80	2	1,28	32,50	40	51,20	20	1.320	-
40x80 / 16"x32" rett.	400x800	9	Pallet	90	3	0,96	19,00	30	28,80	20	590	-
60x60 / 24"x24" rett./nat.	596x596	9	Pallet	120	3	1,08	21,20	40	43,20	20	868	-
30x60 / 12"x24" rett./nat.	297x596	9	Pallet	240	6	1,08	21,20	40	43,20	20	868	-
30x60 / 12"x24" / T	-	9	Pallet	-	6	1,08	20,50	40	43,20	20	840	-

I pezzi speciali, per effetto delle lavorazioni, possono presentare variazioni di tonalità. Due to working process, special trims may show variations in tonality.
L'unità minima di vendita per tutti gli articoli (fondi, decori e pezzi speciali) è la scatola completa. The minimum sales quantity for all items (plain tiles, decorations and special trims) is one full box.
I dati relativi agli imballi sono aggiornati al momento della stampa del catalogo e pertanto possono subire variazioni nel corso del tempo.
Data referring to packaging have been update at time of printing; the actual data may be slightly different.
Approfondimenti sugli imballi a pag. 282 dell'area tecnica. Details concerning packaging available at page 282 inside technical area.

NORDIK STONE

GRES PORCELLANATO A MASSA COLORATA / FULL BODY COLORED PORCELAIN TILES

SUPERFICI / SURFACES



Naturale
Natural



Lappato
Honed



Grip
Antislippery

FORMATI / SIZES



120x120
48"x48"



60x120
24"x48"



90x90
36"x36"



60x60
24"x24"



30x60
12"x24"



9 mm



90x90
36"x36"



20 mm

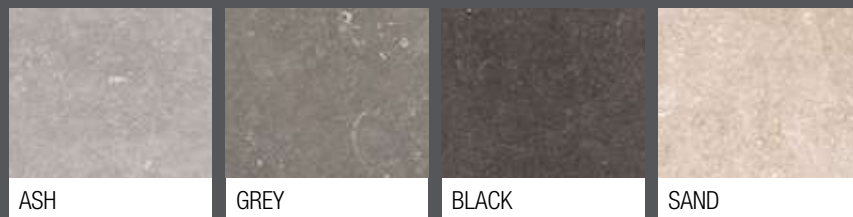

ASH

GREY

BLACK

SAND



NORDIK STONE BLACK RETT. 60X120

ASH



± 9 mm





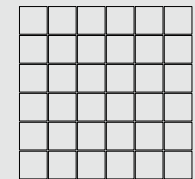







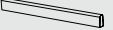

120x120 RETT.	0004829	M. 102,00
120x120 LAPP. RETT.	0004830	M. 119,00
60x120 RETT.	0004832	M. 70,00
60x120 LAPP. RETT.	0004833	M. 80,00
90x90 RETT.	0005060	M. 76,50
60x60 RETT.	0004887	M. 53,50
60x60 GRIP RETT.	0004898	M. 53,50
30x60 RETT.	0004888	M. 48,00

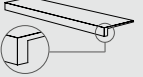
30x30

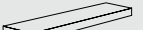

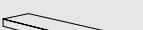
0004839 ± 9 mm
MOSAICO ASH RETT.
M. 104,00 

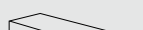
± 9 mm

	BATTISCOPA		5,5x60
	RETT.	0004893	P. 6,50
	BATTISCOPA		5,5x80
	RETT.	0004843	P. 8,00
	BATTISCOPA		5,5x120
	LAPP. RETT.	0004863	P. 12,50
	GRADONE PLUS		32x120x4,5x2
	RETT.	0004847	P. 169,00
	LAPP. RETT.	0004867	P. 179,00
	ANGOLARE PLUS SX		32x120x4,5x2
	RETT.	0004851	P. 196,00
	LAPP. RETT.	0004871	P. 206,00
	ANGOLARE PLUS DX		32x120x4,5x2
	RETT.	0004855	P. 196,00
	LAPP. RETT.	0004875	P. 206,00
	GRADONE JOLLY		40x120x20
	RETT.	0004859	P. 169,00
	LAPP. RETT.	0004879	P. 179,00

60x120

GREY

±9 mm

120x120 RETT.	0003749	M. 102,00
120x120 LAPP. RETT.	0004212	M. 119,00
60x120 RETT.	0004141	M. 70,00
60x120 LAPP. RETT.	0004215	M. 80,00
90x90 RETT.	0005057	M. 76,50
60x60 RETT.	0004159	M. 53,50
60x60 GRIP RETT.	0004895	M. 53,50
30x60 RETT.	0004345	M. 48,00

X20 R11 ±20 mm

90x90 RETT.	0004236	M. 99,00
--------------------	----------------	-----------------





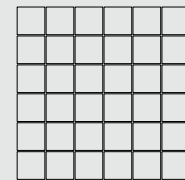







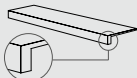

Per la serie completa vedi pag.: 238
For the complete collection see at page: 238

30x30

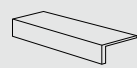

0004836 ±9 mm
MOSAICO GREY RETT.
M. 104,00 

±9 mm

	BATTISCOPA 	5,5x60
	RETT.	0004890 P. 6,50
	BATTISCOPA 	5,5x80
	RETT.	0004840 P. 8,00
	BATTISCOPA 	5,5x120
	LAPP. RETT.	0004860 P. 12,50
	GRADONE PLUS 	32x120x4,5x2
	RETT.	0004844 P. 169,00
	LAPP. RETT.	0004864 P. 179,00
	ANGOLARE PLUS SX 	32x120x4,5x2
	RETT.	0004848 P. 196,00
	LAPP. RETT.	0004868 P. 206,00
	ANGOLARE PLUS DX 	32x120x4,5x2
	RETT.	0004852 P. 196,00
	LAPP. RETT.	0004872 P. 206,00
	GRADONE JOLLY 	40x120x20
	RETT.	0004856 P. 169,00
	LAPP. RETT.	0004876 P. 179,00

120x120

BLACK

±9 mm

120x120 RETT.	0003750	M. 102,00
120x120 LAPP. RETT.	0004213	M. 119,00
60x120 RETT.	0004142	M. 70,00
60x120 LAPP. RETT.	0004216	M. 80,00
90x90 RETT.	0005058	M. 76,50
60x60 RETT.	0004160	M. 53,50
60x60 GRIP RETT.	0004896	M. 53,50
30x60 RETT.	0004346	M. 48,00

X20 R11 ±20 mm

90x90 RETT.	0004237	M. 99,00
--------------------	----------------	-----------------





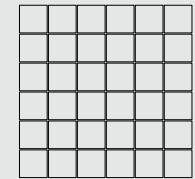







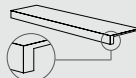

Per la serie completa vedi pag.: 238
For the complete collection see at page: 238

30x30

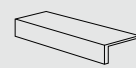

0004837 ±9 mm
MOSAICO BLACK RETT.
M. 104,00 

±9 mm

	BATTISCOPA 	5,5x60
	RETT.	0004891 P. 6,50
	BATTISCOPA 	5,5x80
	RETT.	0004841 P. 8,00
	BATTISCOPA 	5,5x120
	LAPP. RETT.	0004861 P. 12,50
	GRADONE PLUS 	32x120x4,5x2
	RETT.	0004845 P. 169,00
	LAPP. RETT.	0004865 P. 179,00
	ANGOLARE PLUS SX 	32x120x4,5x2
	RETT.	0004849 P. 196,00
	LAPP. RETT.	0004869 P. 206,00
	ANGOLARE PLUS DX 	32x120x4,5x2
	RETT.	0004853 P. 196,00
	LAPP. RETT.	0004873 P. 206,00
	GRADONE JOLLY 	40x120x20
	RETT.	0004857 P. 169,00
	LAPP. RETT.	0004877 P. 179,00

60x120

SAND



±9 mm

120x120 RETT.	0003751	M. 102,00
120x120 LAPP. RETT.	0004214	M. 119,00
60x120 RETT.	0004143	M. 70,00
60x120 LAPP. RETT.	0004217	M. 80,00
90x90 RETT.	0005059	M. 76,50
60x60 RETT.	0004161	M. 53,50
60x60 GRIP RETT.	0004897	M. 53,50
30x60 RETT.	0004347	M. 48,00

30x30

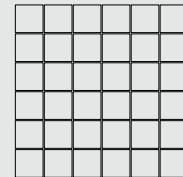

0004838 ±9 mm
MOSAICO SAND RETT.
M. 104,00



La non perfetta continuità di linee, rilievi o motivi grafici tra piastrelle adiacenti è naturale conseguenza del processo produttivo, pertanto non costituisce un vizio del prodotto

Any variations in graphic designs or textures between adjacent tiles are a natural consequence of the manufacturing process and do not constitute a product defect.

60x120 DOMINO SAND RETT.	0004881	M. 80,00
30x120 DOMINO SAND RETT.	0004883	M. 80,00



60x120 DOMINO BLACK RETT.	0004880	M. 80,00
30x120 DOMINO BLACK RETT.	0004882	M. 80,00

GRES PORCELLANATO A MASSA COLORATA - CLASSIFICAZIONE SECONDO NORME EN 14411 (ISO 13006) ALLEGATO G GRUPPO B1a
FULL BODY COLORED PORCELAIN TILES - CLASSIFICATION IN ACCORDANCE WITH EN 14411 (ISO 13006) ANNEX G GROUP B1a

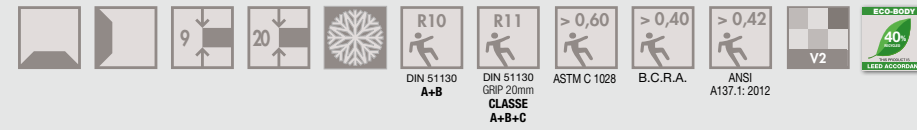

			±9 mm
	BATTISCOPIA		5,5x60
	RETT.	0004892	P. 6,50
	BATTISCOPIA		5,5x80
	RETT.	0004842	P. 8,00
	BATTISCOPIA		5,5x120
	LAPP. RETT.	0004862	P. 12,50
	GRADONE PLUS		32x120x4,5x2
	RETT.	0004846	P. 169,00
	LAPP. RETT.	0004866	P. 179,00
	ANGOLARE PLUS SX		32x120x4,5x2
	RETT.	0004850	P. 196,00
	LAPP. RETT.	0004870	P. 206,00
	ANGOLARE PLUS DX		32x120x4,5x2
	RETT.	0004854	P. 196,00
	LAPP. RETT.	0004874	P. 206,00
	GRADONE JOLLY		40x120x20
	RETT.	0004858	P. 169,00
	LAPP. RETT.	0004878	P. 179,00

F.to nominale Nominal size	F.to reale (mm) Work size (mm)	Spessore Thickness	Tipologia imballo Type of packing	Lastre/Imballo Slabs/Packing	Pz/Imballo Pcs/Packing	Mq/Scatola SqM/Box	Kg/Scatola Kg/Box	Scatole/Imballo Box/Packing	Mq totali SqM total	Kg/Imballo Kg/Packing	Kg totali Kg total	Prezzo imballo Packing Price
120x120 / 48"x48" rett./lapp.	1194x1194	9 mm	Pallet con sponde Pallet with sides	36	2	2,88	56,16	18	51,84	40	1.051	-
60x120 / 24"x48" rett./lapp.	596x1194	9 mm	Pallet	60	2	1,44	28,00	30	43,20	20	860	-
30x120 / 12"x 48" rett.	297x1194	9 mm	Pallet	144	4	1,44	28,00	36	51,84	20	1.028	-
90x90 / 36"x 36" rett.	900x900	9 mm	Pallet	88	2	1,62	36,50	40	32,40	20	750	-
60x60 / 24"x24" rett.	596x596	9 mm	Pallet	120	3	1,08	21,20	40	43,20	20	868	-
30x60 / 12"x24" rett.	297x596	9 mm	Pallet	240	6	1,08	21,20	40	43,20	20	868	-
90x90 / 36"x36" rett.	896x896	20 mm	Pallet	30	1	0,81	36,60	30	24,30	20	1.118	-

I pezzi speciali, per effetto delle lavorazioni, possono presentare variazioni di tonalità. Due to working process, special trims may show variations in tonality.
L'unità minima di vendita per tutti gli articoli (fondi, decori e pezzi speciali) è la scatola completa. The minimum sales quantity for all items (plain tiles, decorations and special trims) is one full box.
I dati relativi agli imballi sono aggiornati al momento della stampa del catalogo e pertanto possono subire variazioni nel corso del tempo.
Data referring to packaging have been update at time of printing; the actual data may be slightly different.
Approfondimenti sugli imballi a pag. 282 dell'area tecnica. Details concerning packaging available at page 282 inside technical area.

NORDIK STONE

MULTIPLE SENSATIONS

MULTIPLE SENSATIONS è la materioteca di FLAVIKER, un contenitore di materie diverse sapientemente combinate insieme per dare vita ad atmosfere sorprendenti ed in linea con le principali tendenze del design contemporaneo.

MULTIPLE SENSATIONS from FLAVIKER is a collection of different materials which can be combined to create striking and original atmospheres in line with the latest trends in contemporary design.

NORDIK STONE



ASH



GREY



BLACK



SAND

NORDIK WOOD



SMOKED



GOLD



BEIGE



BROWN

REBEL

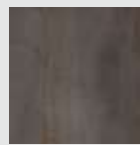

LEAD



WHITE

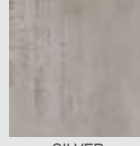

SILVER

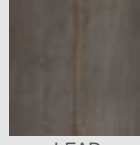

LEAD

SUPREME/ SUPREME EVO



STAT. SUPERIOR



STATUARIO VENATO

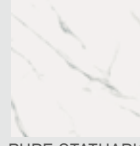

PURE STATUARIO

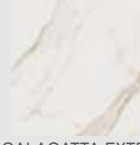

CALACATTA EXTRA

HYPER

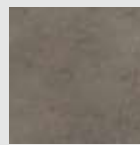

TAUPE

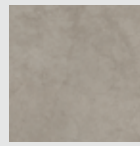

GREY

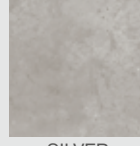

SILVER

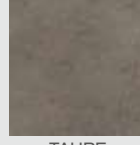

TAUPE



NORDIK STONE BLACK,
NORDIK WOOD BEIGE



NORDIK STONE BLACK,
HYPER SILVER



NORDIK STONE BLACK,
COZY HAVANA



NORDIK STONE SAND
REBEL LEAD

STILL NO_W

WIDE
SUPERSIZE SLABS

LASTRE IN GRES PORCELLANATO A MASSA COLORATA / FULL BODY COLORED PORCELAIN SLABS

SUPERFICI / SURFACES



Naturale
Natural

FORMATI / SIZES

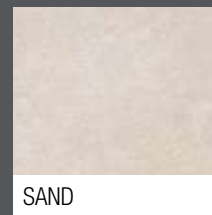
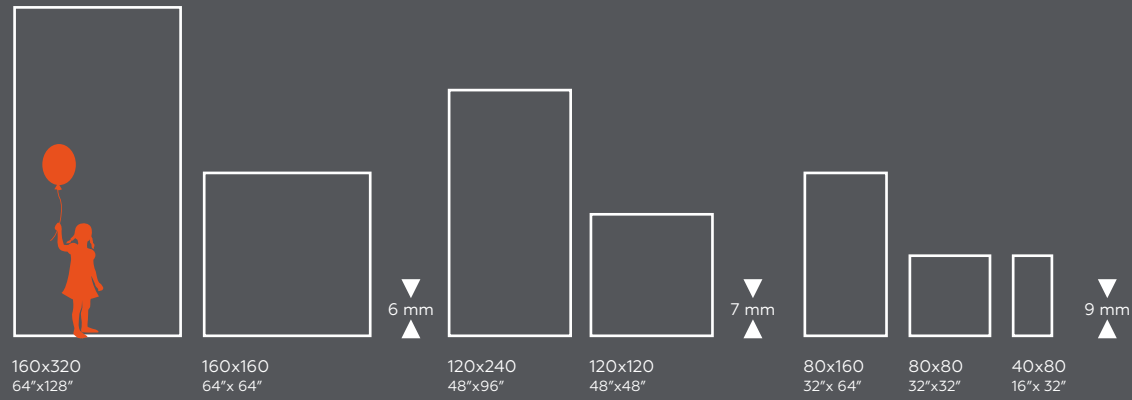

SAND

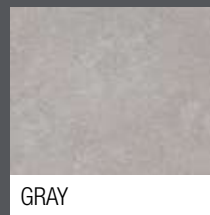

GRAY



COAL



STILL NO_W COAL 120X240 _ GRAY 120X240

WIDE
SUPERSIZE SLABS



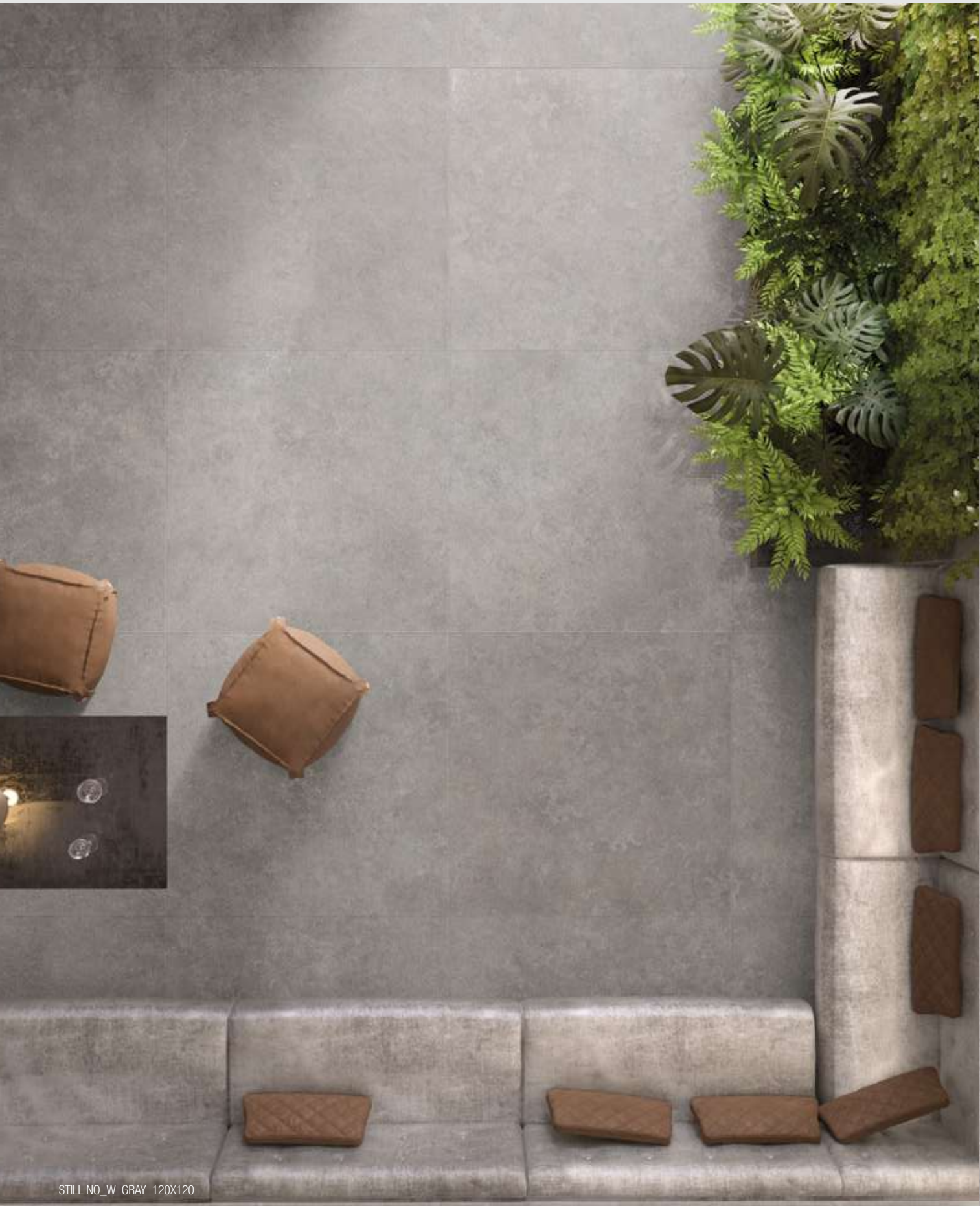

STILL NO_W GRAY 120X120

120x240

7 mm		
120x240	RETT.	0000439 M. 132,00
120x120	RETT.	0000442 M. 102,00
9 mm		
* 80x160	RETT.	0000433 M. 102,00
* 80x80	RETT.	0000436 M. 70,00
* 40x80	RETT.	0000966 M. 53,50
20 mm		
X20	R11	
60x120	RETT.	0000949 M. 99,00

Per la serie completa vedi pag.: 240
For the complete collection see at page: 240

* Fino ad esaurimento scorte l'art. verrà consegnato a spessore 7 mm.
The item will be delivered 7 mm thick until stocks are exhausted.



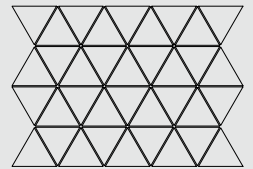

34x26

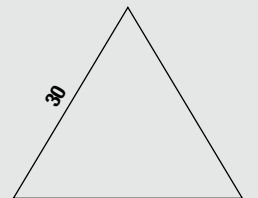

0001000
MOS. TRIANGOLI GRAY RETT.
M. 349,00 



0000703
TRIANGOLO 30 GRAY RETT.
M. 249,00  = 0,54 mq

9 mm		
* BATTISCOPIA		5,5x80
RETT.	0000706	P. 8,00
7 mm		
GRADONE PLUS		32x120x4,5x1,5
RETT.	0000709	P. 169,00
ANGOLARE PLUS SX		32x120x4,5x1,5
RETT.	0000712	P. 196,00
ANGOLARE PLUS DX		32x120x4,5x1,5
RETT.	0000715	P. 196,00
GRADONE JOLLY		40x120x20
RETT.	0004546	P. 169,00

COAL

✂ 6 mm

* 160x320 RETT. 0000428 M. 168,00

* 160x160 RETT. 0000431 M. 152,00

✂ 7 mm

120x240 RETT. 0000440 M. 132,00

120x120 RETT. 0000443 M. 102,00

✂ 9 mm

* 80x160 RETT. 0000434 M. 102,00

* 80x80 RETT. 0000437 M. 70,00

* 40x80 RETT. 0000967 M. 53,50

X20 R11 ✂ 20 mm

60x120 RETT. 0000950 M. 99,00

Per la serie completa vedi pag.: 240
For the complete collection see at page: 240

* Fino ad esaurimento scorte l'art. verrà consegnato a spessore 7 mm.
The item will be delivered 7 mm thick until stocks are exhausted.

34x26

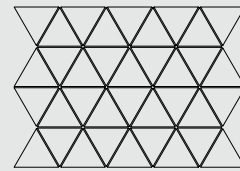

0001001
MOS.TRIANGOLI COAL RETT.
M. 349,00 

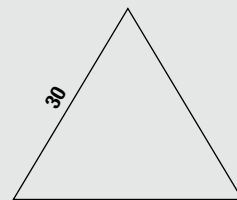

0000704
TRIANGOLO 30 COAL RETT.
M. 249,00  = 0,54 mq

✂ 9 mm

* BATTISCOPA  5,5x80

RETT. 0000707 P. 8,00

✂ 7 mm

 **GRADONE PLUS**  32x120x4,5x1,5

RETT. 0000710 P. 169,00

 **ANGOLARE PLUS SX**  32x120x4,5x1,5

RETT. 0000713 P. 196,00

 **ANGOLARE PLUS DX**  32x120x4,5x1,5

RETT. 0000716 P. 196,00

 **GRADONE JOLLY**  40x120x20

RETT. 0004547 P. 169,00

160x320

SAND

✂ 6 mm

* 160x320 RETT. 0000426 M. 168,00

* 160x160 RETT. 0000429 M. 152,00

✂ 7 mm

120x240 RETT. 0000438 M. 132,00

120x120 RETT. 0000441 M. 102,00

✂ 9 mm

* 80x160 RETT. 0000432 M. 102,00

* 80x80 RETT. 0000435 M. 70,00

* 40x80 RETT. 0000965 M. 53,50

X20 R11 ✂ 20 mm

60x120 RETT. 0000948 M. 99,00

Per la serie completa vedi pag.: 240
For the complete collection see at page: 240

* Fino ad esaurimento scorte l'art. verrà consegnato a spessore 7 mm.
The item will be delivered 7 mm thick until stocks are exhausted.

34x26

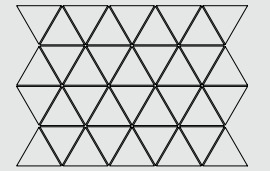

0000999
MOS.TRIANGOLI SAND RETT.
M. 349,00 

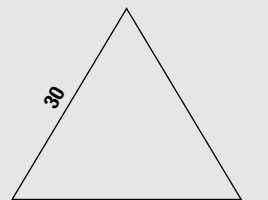



0000702
TRIANGOLO 30 SAND RETT.
M. 249,00  = 0,54 mq

✂ 9 mm

* BATTISCOPA  5,5x80

RETT. 0000705 P. 8,00

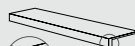
✂ 7 mm

 **GRADONE PLUS**  32x120x4,5x1,5

RETT. 0000708 P. 169,00

 **ANGOLARE PLUS SX**  32x120x4,5x1,5

RETT. 0000711 P. 196,00

 **ANGOLARE PLUS DX**  32x120x4,5x1,5

RETT. 0000714 P. 196,00

 **GRADONE JOLLY**  40x120x20

RETT. 0004545 P. 169,00

80x80

01.1 2 colori

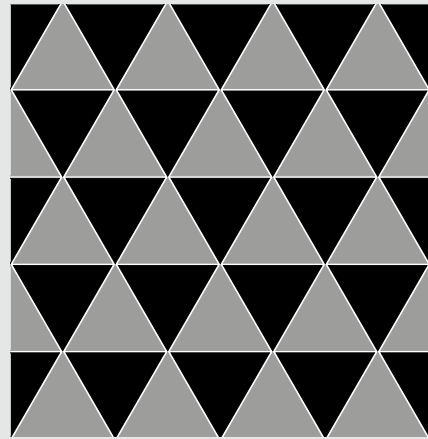

COLOR 1 50% ■
COLOR 2 50% ■

01.2 2 colori

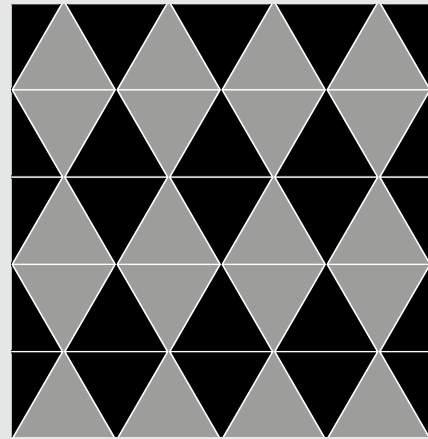

COLOR 1 50% ■
COLOR 2 50% ■

01.3 2 colori

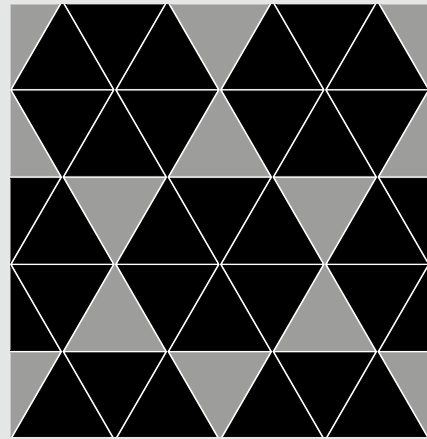

COLOR 1 75% ■
COLOR 2 25% ■

01.4 2 colori

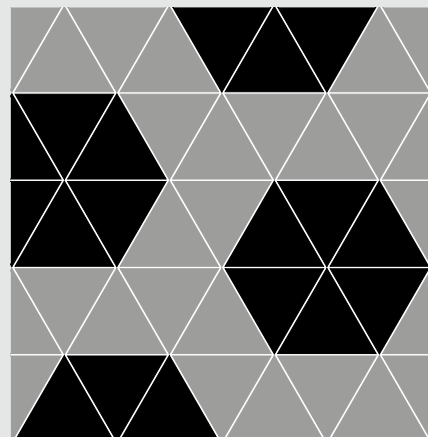

COLOR 1 57% ■
COLOR 2 43% ■

01.5 3 colori

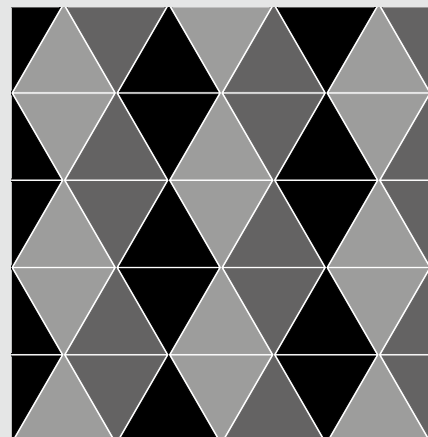

COLOR 1 33,33% ■ COLOR 3 33,33% ■
COLOR 2 33,33% ■

01.6 3 colori

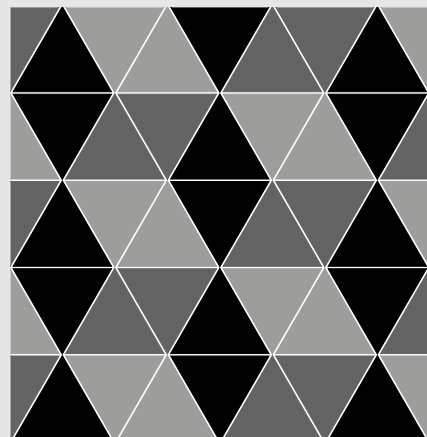

COLOR 1 33,33% ■ COLOR 3 33,33% ■
COLOR 2 33,33% ■

01.7 3 colori

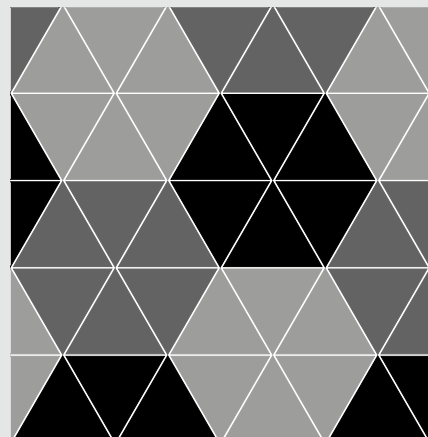

COLOR 1 33,33% ■ COLOR 3 33,33% ■
COLOR 2 33,33% ■

01.8 4 colori

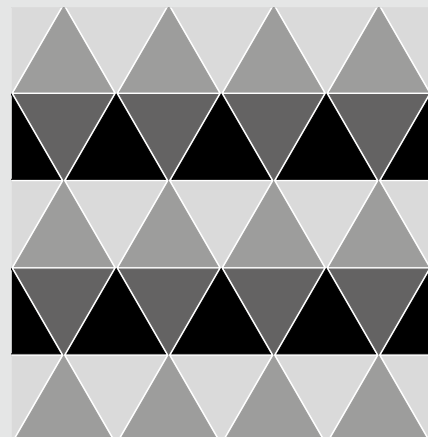

COLOR 1 25% ■ COLOR 3 25% ■
COLOR 2 25% ■ COLOR 4 25% ■

O2 2 colori

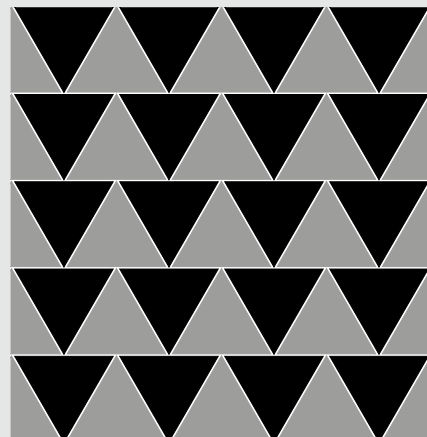

COLOR 1 50% ■
COLOR 2 50% ■

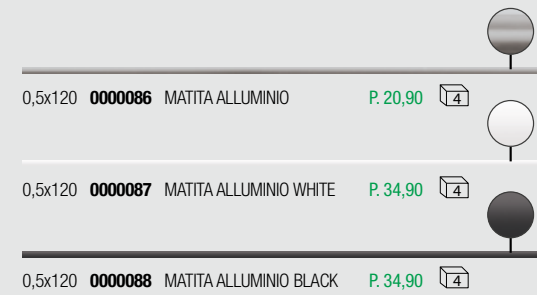

Articoli realizzati in alluminio per l'uso a parete, adatti a raccordare piastrelle di diverso spessore (9 mm / 7 mm).

Aluminium strip for use between wall tiles of different thicknesses (9 mm / 7 mm).

LASTRE IN GRES PORCELLANATO A MASSA COLORATA - CLASSIFICAZIONE SECONDO NORME EN 14411 (ISO 13006) ALLEGATO G GRUPPO BIa
FULL BODY COLORED PORCELAIN SLABS - CLASSIFICATION IN ACCORDANCE WITH EN 14411 (ISO 13006) ANNEX G GROUP BIa



F.to nominale Nominal size	F.to reale (mm) Work size (mm)	Spessore Thickness	Tipologia imballo Type of packing	Lastre/Imballo Slabs/Packing	Pz/Imballo Pcs/Packing	Mq/Scatola Sqm/Box	Kg/Scatola Kg/Box	Scatole/Imballo Box/Packing	Mq totali Sqm total	Kg/Imballo Kg/Packing	Kg totali Kg total	Prezzo imballo Packing Price
160x320 / 64"x128" rett.	1596,5x3195	6 mm	Cassa Crate	14	-	-	-	-	71,86	139	1.214	€ 130,00
			Cavalletto container Container Rack pallet	36	-	-	-	-	184,32	180	2.945	€ 235,00
120x240 / 48"x96" rett.	1194x2390	7 mm	Cavalletto Rack pallet	40	-	-	-	-	115,20	100	2.116	€ 120,00
			Cassa Crate	20	-	-	-	-	57,60	100	1.108	€ 100,00
160x160 / 64"x 64" rett.	1596,5x1596,5	6 mm	Cassa (160x160) Crate	28	-	-	-	-	71,68	75	1.150	€ 90,00
			Cassa (160x320) Crate	28	-	-	-	-	71,68	139	1.214	€ 130,00
120x120 / 48"x48" rett.	1194x1194	7 mm	Cavalletto container Container Rack pallet	40	-	-	-	-	115,20	115	2.131	€ 190,00
			Cavalletto container Container Rack pallet	36	-	-	-	-	92,16	95	1.477	€ 170,00
120x120 / 48"x48" rett.	1194x1194	7 mm	Pallet con sponde Pallet with sides	44	2	2,88	50,40	22	63,36	40	1.149	-
			Cavalletto Rack pallet	44	2	2,56	50,00	22	56,32	70	1.170	€ 50,00
80x160 / 32"x 64" rett.	797,25x1596,5	9 mm	Pallet con sponde Pallet with sides	44	2	2,56	50,00	22	56,32	40	1.140	-
			Cavalletto Rack pallet	44	2	2,56	50,00	22	56,32	70	1.170	€ 50,00
80x80 / 32"x 32" rett.	797,25x797,25	9 mm	Pallet	88	2	1,28	25,00	44	56,32	20	1.120	-
40x80 / 16"x 32" rett.	397,62x797,25	9 mm	Pallet	90	3	0,96	19,00	30	28,80	20	590	-
60x120 / 24"x 48" rett.	600x1200	20 mm	Pallet	27	1	0,72	34,36	27	19,44	20	943	-

I pezzi speciali, per effetto delle lavorazioni, possono presentare variazioni di tonalità. Due to working process, special trims may show variations in tonality.
L'unità minima di vendita per tutti gli articoli (fondi, decori e pezzi speciali) è la scatola completa. The minimum sales quantity for all items (plain tiles, decorations and special trims) is one full box.
I dati relativi agli imballi sono aggiornati al momento della stampa del catalogo e pertanto possono subire variazioni nel corso del tempo.
Data referring to packaging have been update at time of printing; the actual data may be slightly different.
Approfondimenti sugli imballi a pag. 282 dell'area tecnica. Details concerning packaging available at page 282 inside technical area.

STILL NO_W MULTIPLE SENSATIONS

WIDE
SUPERSIZE SLABS

MULTIPLE SENSATIONS è la materioteca di FLAVIKER, un contenitore di materie diverse sapientemente combinate insieme per dare vita ad atmosfere sorprendenti ed in linea con le principali tendenze del design contemporaneo.

MULTIPLE SENSATIONS from FLAVIKER is a collection of different materials which can be combined to create striking and original atmospheres in line with the latest trends in contemporary design.

STILL NO_W

RIVER

SUPREME

COZY

HANGAR



SAND



EARTH



CALACATTA EXTRA

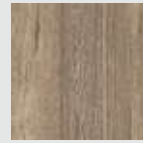

BROWN



SAND



GRAY



MOON

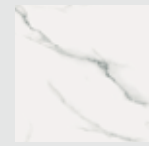

PURE STATUARIO



HAVANA



COAL

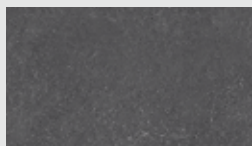

COAL

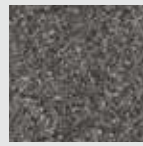

LEAD



EXOTIC BROWN

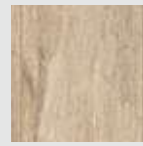

HONEY



COAL



STILL NO_W GRAY
HANGAR ASH, COAL, SMOKE



STILL NO_W SAND
SUPREME CALACATTA EXTRA LUX*



STILL NO_W COAL
SUPREME EXOTIC BROWN LUX+



STILL NO_W COAL
COZY HONEY

NO_W

GRES PORCELLANATO A MASSA COLORATA / FULL BODY COLORED PORCELAIN TILES

SUPERFICI / SURFACES



Naturale
Natural

FORMATI / SIZES

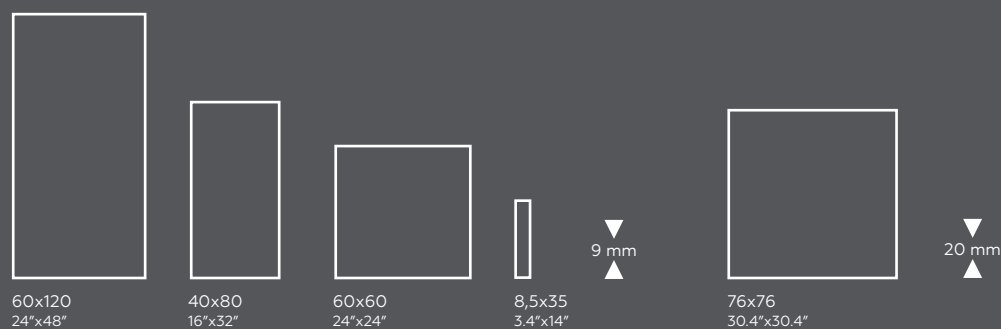

60x120
24"x48"

40x80
16"x32"

60x60
24"x24"

8,5x35
3.4"x14"

9 mm

76x76
30.4"x30.4"

20 mm

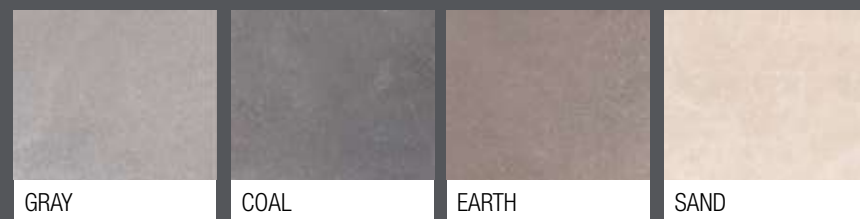

GRAY

COAL

EARTH

SAND



NO_W GRAY 60X60 / 8,5X35

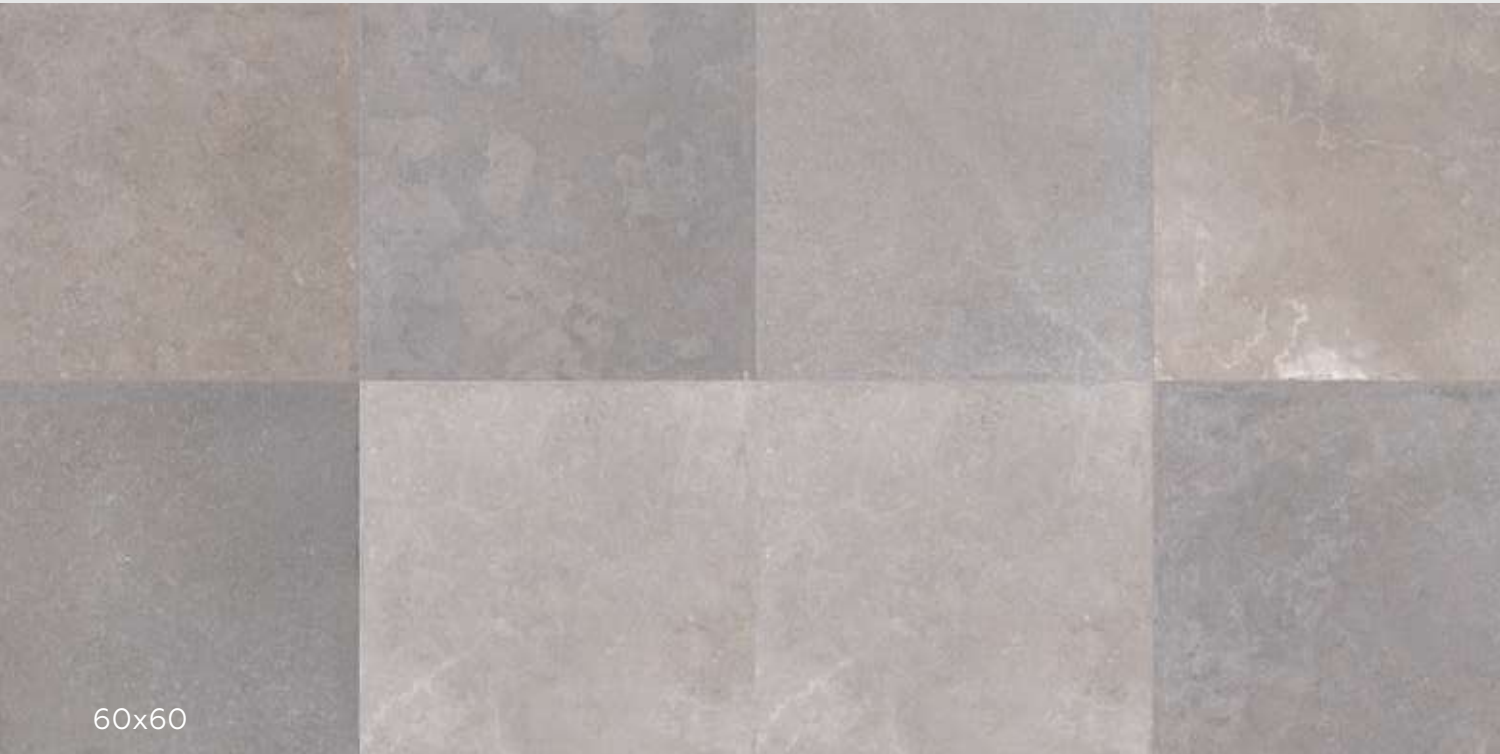

60x60



60x60

R: Rettificato | Rectified

*Per la serie completa vedi pag. 242 | For the complete collection see page 242

R: Rettificato | Rectified

60x120

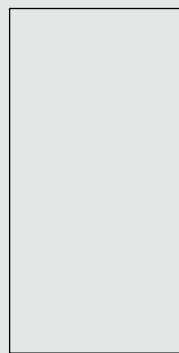

NO 6122 R M. 70,00

40x80



NO 4822 R M. 53,50

60x60



NO 6022 R M. 53,50

30x40



NO MO 222
MOSAICO BRICK
P. 18,00 

30x30

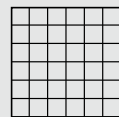

NO MO 221
MOSAICO 5x5
M. 104,00 

R11

20mm
76x76
X20



NO 7622 M M. 99,00

Per la serie completa vedi pag. 212
For the complete collection see page 212

60x120

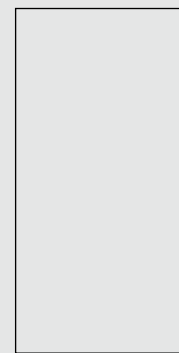

NO 6190 R M. 70,00

40x80



NO 4890 R M. 53,50

60x60



NO 6090 R M. 53,50

30x40

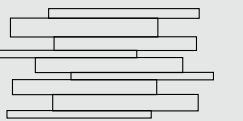

NO MO 902
MOSAICO BRICK
P. 18,00 

30x30

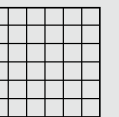

NO MO 901
MOSAICO 5x5
M. 104,00 



Battiscopa
NO BN 226 5,5x60 P. 6,50 

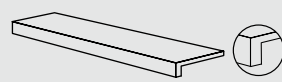

Gradone Plus 32x120x4,5x2
NO RT 222 P. 169,00 

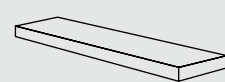

Angolare Plus sx 32x120x4,5x2
NO RA 22S
Angolare Plus dx 32x120x4,5x2
NO RA 22D
P. 196,00 



Battiscopa
NO BN 906 5,5x60 P. 6,50 



Gradone Plus 32x120x4,5x2
NO RT 902 P. 169,00 

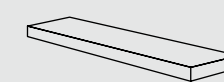

Angolare Plus sx 32x120x4,5x2
NO RA 90S
Angolare Plus dx 32x120x4,5x2
NO RA 90D
P. 196,00 



60x60



60x60

R: Rettificato | Rectified

*Per la serie completa vedi pag. 242 | For the complete collection see page 242

R: Rettificato | Rectified

60x120



NO 6134 R M. 70,00

40x80



NO 4834 R M. 53,50

60x60



NO 6034 R M. 53,50

30x40



NO MO 342
MOSAICO BRICK
P. 18,00

30x30

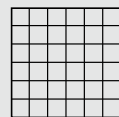

NO MO 341
MOSAICO 5x5
M. 104,00

60x120

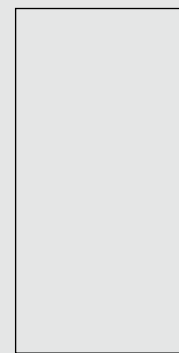

NO 6130 R M. 70,00

40x80



NO 4830 R M. 53,50

60x60

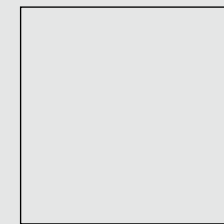

NO 6030 R M. 53,50

30x40



NO MO 302
MOSAICO BRICK
P. 18,00

30x30

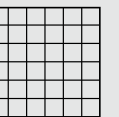

NO MO 301
MOSAICO 5x5
M. 104,00



Battiscopa
NO BN 346 5,5x60 P. 6,50

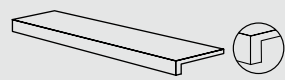

Gradone Plus 32x120x4,5x2
NO RT 342 P. 169,00

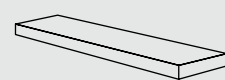

Angolare Plus sx 32x120x4,5x2
NO RA 34S
Angolare Plus dx 32x120x4,5x2
NO RA 34D
P. 196,00



Battiscopa
NO BN 306 5,5x60 P. 6,50



Gradone Plus 32x120x4,5x2
NO RT 302 P. 169,00

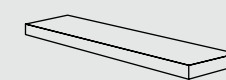

Angolare Plus sx 32x120x4,5x2
NO RA 30S
Angolare Plus dx 32x120x4,5x2
NO RA 30D
P. 196,00

(R11)

20mm
76x76
X20

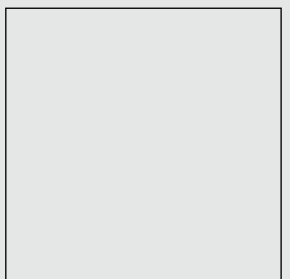

NO 7630 M M. 99,00

Per la serie completa vedi pag. 212
For the complete collection see page 212

NO_W

GRES PORCELLANATO
PORCELAIN TILES

RESIZE



8,5x35
NO 83 522 M. 53,50
NO_W GRAY

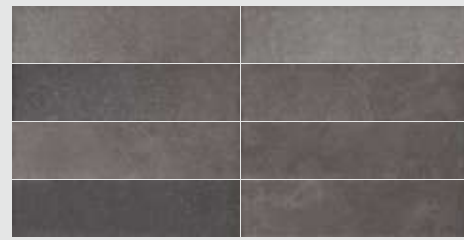

8,5x35
NO 83 590 M. 53,50
NO_W COAL



8,5x35
NO DI 002 P. 16,00
DEC. SIDEREAL COLD MIX 4

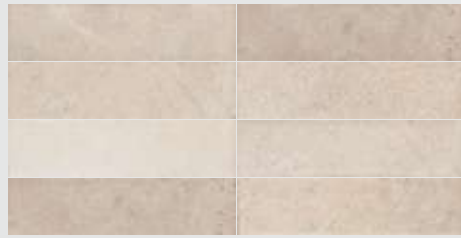

8,5x35
NO 83 530 M. 53,50
NO_W SAND



8,5x35
NO 83 534 M. 53,50
NO_W EARTH



8,5x35
NO DI 001 P. 16,00
DEC. SIDEREAL HOT MIX 4



6x30
DK DF 131 P. 13,00
FASCIA DAKOTA NATURALE



6x30
DK DF 231 P. 13,00
FASCIA DAKOTA TORTORA



6x30
DK DF 301 P. 13,00
FASCIA DAKOTA AVANA



NO_W EARTH 8,5x35 / DEC. SIDEREAL HOT MIX 4 8,5x35
BACKSTAGE TAN 60x60

0,5x120	0000086	MATITA ALLUMINIO	P. 20,90	
0,5x120	0000087	MATITA ALLUMINIO WHITE	P. 34,90	
0,5x120	0000088	MATITA ALLUMINIO BLACK	P. 34,90	
0,5x120	0000556	MATITA ALLUMINIO RAME	P. 34,90	
0,5x120	0000557	MATITA ALLUMINIO BRONZO	P. 34,90	

Articoli realizzati in alluminio per l'uso a parete, adatti a raccordare piastrelle di diverso spessore (9 mm / 7 mm).

Aluminium strip for use between wall tiles of different thicknesses (9 mm / 7 mm).



NO_W GRAY 60x60 / 8,5x35
PLACE_2B DUBLIN TAUPE 20x120 / TAUPE-BEIGE 8,5x35

NO_W	8,5x35	66,7%
DUBLIN	8,5x35	33,3%
		100%

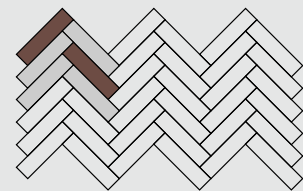

GRES PORCELLANATO A MASSA COLORATA - CLASSIFICAZIONE SECONDO NORME EN 14411 (ISO 13006) ALLEGATO G GRUPPO Bla
FULL BODY COLORED PORCELAIN TILES - CLASSIFICATION IN ACCORDANCE WITH EN 14411 (ISO 13006) ANNEX G GROUP Bla



Fto nominale Nominal size	Fto reale (mm) Work size (mm)	Spessore Thickness	Tipologia imballo Type of packing	Lastre/Imballo Slabs/Packing	Pz/Imballo Pcs/Packing	Mq/Scatola SqM/Box	Kg/Scatola Kg/Box	Scatole/Imballo Box/Packing	Mq totali SqM total	Kg/Imballo Kg/Packing	Kg totali Kg total	Prezzo imballo Packing Price
60x120 / 24"x48" rett.	596x1194	9	Pallet	60	2	1,44	28,00	30	43,20	20	860	-
40x80 / 16"x32" rett.	400x800	9	Pallet	90	3	0,96	19,00	30	28,80	20	590	-
60x60 / 24"x24" rett.	596x596	9	Pallet	120	3	1,08	21,20	40	43,20	20	868	-
8,5x35 / 3.4"x14" nat.	-	9	Pallet	1680	20	0,602	12,50	84	50,57	20	1065	-
76x76 / 30.4"x30.4" nat.	-	20	Pallet	45	1	0,58	29,73	45	26,10	20	1353	-

I pezzi speciali, per effetto delle lavorazioni, possono presentare variazioni di tonalità. Due to working process, special trims may show variations in tonality. L'unità minima di vendita per tutti gli articoli (fondi, decori e pezzi speciali) è la scatola completa. The minimum sales quantity for all items (plain tiles, decorations and special trims) is one full box. I dati relativi agli imballi sono aggiornati al momento della stampa del catalogo e pertanto possono subire variazioni nel corso del tempo. Data referring to packaging have been update at time of printing; the actual data may be slightly different. Approfondimenti sugli imballi a pag. 282 dell'area tecnica. Details concerning packaging available at page 282 inside technical area.

FORWARD

GRES PORCELLANATO A MASSA COLORATA / FULL BODY COLORED PORCELAIN TILES

SUPERFICI / SURFACES



Naturale
Natural



Lappato
Honed

FORMATI / SIZES



40x80
16"x32"



60x60
24"x24"



30x60
12"x24"



20x40
8"x16"



20x20
8"x8"



9 mm



40x80
16"x32"



20 mm



SAND



EARTH



GREY

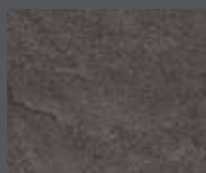

BLACK



FORWARD BLACK RETT



R: Rettificato | Rectified
P: Lappato | Honed

*Per la serie completa vedi pag. 244 | For the complete collection see page 244

R: Rettificato | Rectified
P: Lappato | Honed

40x80

60x60

30x60

30x60 MIX SIZES RETT.
6 pz 6 pz 6 pz
5x60 - 10x60 - 15x60

30x30

FW 4813 R
M. 53,50

FW 6013 R
FW 6013 P
M. 53,50
M. 66,00

FW 3613 R
M. 48,00

FW MIX13
M. 78,00

FW MO 131
MOSAICO NAT.
M. 104,00

40x80

60x60

30x60

30x60 MIX SIZES RETT.
6 pz 6 pz 6 pz
5x60 - 10x60 - 15x60

30x30

FW 4830 R
M. 53,50

FW 6030 R
FW 6030 P
M. 53,50
M. 66,00

FW 3630 R
M. 48,00

FW MIX30
M. 78,00

FW MO 301
MOSAICO NAT.
M. 104,00

Battiscopa Rettificato
FW BN 139 5,5x80 P. 8,00

FW BN 136 5,5x60 P. 6,50

Gradone Plus 33x60x4,5x2
FW RT 136 P. 80,00

Angolare Plus sx 33x60x4,5x2
FW RA 13S
Angolare Plus dx 33x60x4,5x2
FW RA 13D
P. 106,00

Battiscopa Rettificato
FW BN 309 5,5x80 P. 8,00

FW BN 306 5,5x60 P. 6,50

Gradone Plus 33x60x4,5x2
FW RT 306 P. 80,00

Angolare Plus sx 33x60x4,5x2
FW RA 30S
Angolare Plus dx 33x60x4,5x2
FW RA 30D
P. 106,00



60x60



60x60

R: Rettificato | Rectified
P: Lappato | Honed

*Per la serie completa vedi pag. 244 | For the complete collection see page 244

R: Rettificato | Rectified
P: Lappato | Honed

40x80

40x80
FW 4822 R
M. 53,50

60x60
FW 6022 R
FW 6022 P
M. 53,50
M. 66,00

30x60
FW 3622 R
M. 48,00

30x60 MIX SIZES RETT.
6 pz 6 pz 6 pz
5x60 - 10x60 - 15x60
FW MIX 22
M. 78,00

30x30
FW MO 221
MOSAICO NAT.
M. 104,00

40x80

40x80
FW 4890 R
M. 53,50

60x60
FW 6090 R
FW 6090 P
M. 53,50
M. 66,00

30x60
FW 3690 R
M. 48,00

30x60 MIX SIZES RETT.
6 pz 6 pz 6 pz
5x60 - 10x60 - 15x60
FW MIX 90
M. 78,00

30x30
FW MO 901
MOSAICO NAT.
M. 104,00

Battiscopa Rettificato
FW BN 229 5,5x80 P. 8,00
FW BN 226 5,5x60 P. 6,50

Gradone Plus 33x60x4,5x2
FW RT 226 P. 80,00

Angolare Plus sx 33x60x4,5x2
FW RA 22S
Angolare Plus dx 33x60x4,5x2
FW RA 22D
P. 106,00

Battiscopa Rettificato
FW BN 909 5,5x80 P. 8,00
FW BN 906 5,5x60 P. 6,50

Gradone Plus 33x60x4,5x2
FW RT 906 P. 80,00

Angolare Plus sx 33x60x4,5x2
FW RA 90S
Angolare Plus dx 33x60x4,5x2
FW RA 90D
P. 106,00



30x60
FW 3613 FORWARD SAND NAT.
M. 41,00



30x60
FW MO 133 FORWARD SAND BRICK NAT.
M. 44,00



30x60
FW 3622 FORWARD GREY NAT.
M. 41,00



30x60
FW MO 223 FORWARD GREY BRICK NAT.
M. 44,00



OUTDOOR 9 mm (R11)



20x40
FW 2430
FORWARD EARTH NAT.
M. 33,50



20x20
FW 2030
FORWARD EARTH NAT.
M. 33,50



20x40
FW 2422
FORWARD GREY NAT.
M. 33,50



20x20
FW 2022
FORWARD GREY NAT.
M. 33,50

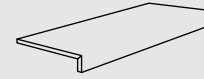

ELLE MONOLITICO FORWARD 15x30 P. 17,50

FW EN 303 FORWARD EARTH

FW EN 223 FORWARD GREY

X20 20 mm (R11)



40x80
FW 4830 M FORWARD EARTH 20mm. NAT.
M. 93,00



40x80
FW 4822 M FORWARD GREY 20mm. NAT.
M. 93,00

Per la serie completa vedi pag. 244
For the complete collection see page 244

GRES PORCELLANATO A MASSA COLORATA - CLASSIFICAZIONE SECONDO NORME EN 14411 (ISO 13006) ALLEGATO G GRUPPO B1a
FULL BODY COLORED PORCELAIN TILES - CLASSIFICATION IN ACCORDANCE WITH EN 14411 (ISO 13006) ANNEX G GROUP B1a



DECORI / DECORS



30x40
FW MO 132
MOSAICO MIX FRWD SAND/EARTH RETT.
P. 18,00



30x40
FW MO 222
MOSAICO MIX FRWD GREY/BLACK RETT.
P. 18,00



3x30
*** FW DP 901**
FASCIA SLATE NERO
P. 12,50

* Art. realizzati con materiali naturali: vedi indicazioni per posa e pulizia a pag. 289 dell'area tecnica.

Items produced with natural materials: check the technical area at page 289.

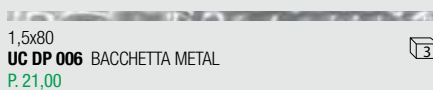

1,5x80
UC DP 006 BACCHETTA METAL
P. 21,00

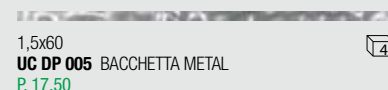

1,5x60
UC DP 005 BACCHETTA METAL
P. 17,50

Fto nominale Nominal size	Fto reale (mm) Work size (mm)	Spessore Thickness	Tipologia imballo Type of packing	Lastre/Imballo Slabs/Packing	Pz/Imballo Pcs/Packing	Mq/Scatola Sqm/Box	Kg/Scatola Kg/Box	Scatole/Imballo Box/Packing	Mq totali Sqm total	Kg/Imballo Kg/Packing	Kg totali Kg total	Prezzo imballo Packing Price
40x80 / 16"x32" rett.	400x800	9	Pallet	90	3	0,96	19,00	30	28,80	20	590	-
60x60 / 24"x24" rett./lapp.	596x596	9	Pallet	120	3	1,08	21,20	40	43,20	20	868	-
30x60 / 12"x24" rett.	297x596	9	Pallet	240	6	1,08	21,20	40	43,20	20	868	-
30x60 / 12"x24" nat.	-	9	Pallet	240	6	1,08	21,20	40	43,20	20	868	-
40x80 / 16"x32" nat.	-	20	Pallet	48	2	0,64	28,26	24	15,36	20	698	-
20x20 / 8"x8" nat.	-	9	Pallet	1920	30	1,20	21,00	64	76,80	20	1.364	-
20x40 / 8"x16" nat.	-	9	Pallet	960	15	1,20	21,00	64	76,80	20	1.364	-

I pezzi speciali, per effetto delle lavorazioni, possono presentare variazioni di tonalità. Due to working process, special trims may show variations in tonality. L'unità minima di vendita per tutti gli articoli (fondi, decori e pezzi speciali) è la scatola completa. The minimum sales quantity for all items (plain tiles, decorations and special trims) is one full box. I dati relativi agli imballi sono aggiornati al momento della stampa del catalogo e pertanto possono subire variazioni nel corso del tempo. Data referring to packaging have been update at time of printing; the actual data may be slightly different. Approfondimenti sugli imballi a pag. 282 dell'area tecnica. Details concerning packaging available at page 282 inside technical area.

QUARZITE

GRES PORCELLANATO A MASSA COLORATA / FULL BODY COLORED PORCELAIN TILES

SUPERFICI / SURFACES



Naturale
Natural

FORMATI / SIZES



30x30
12"x12"



15x30
6"x12"



9 mm

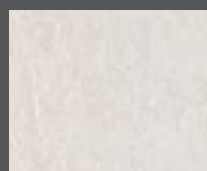

BIANCO

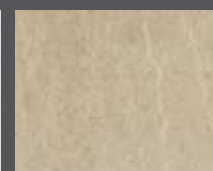

BEIGE



GRIGIO



ANTRACITE



QUARZITE BEIGE 15X30

BIANCO

BEIGE

GRIGIO

ANTRACITE



30x30

30x30

30x30

30x30

30x30

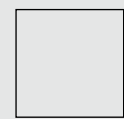

QZ 3010 M. 37,50

15x30

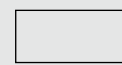

QZ 1310 M. 44,00

30x30

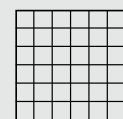

QZ MO 10M
MOSAICO
M. 104,00

30x30



QZ 3030 M. 37,50

15x30

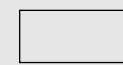

QZ 1330 M. 44,00

30x30

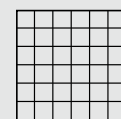

QZ MO 30M
MOSAICO
M. 104,00

30x30



QZ 3022 M. 37,50

30x30

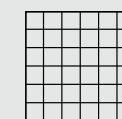

QZ MO 22M
MOSAICO
M. 104,00

30x30



QZ 3091 M. 37,50

30x30

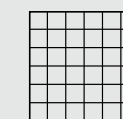

QZ MO 91M
MOSAICO
M. 104,00

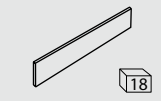

Battiscopa 7x30
QZ BN 103 P. 4,00

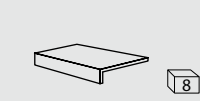

Elle inc. 15x30x4
QZ EN 103 A P. 18,00

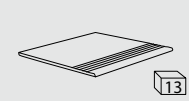

Gradino 30x30
QZ GN 103 P. 11,00

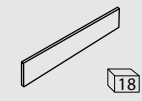

Battiscopa 7x30
QZ BN 303 P. 4,00

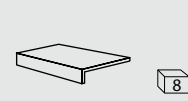

Elle inc. 15x30x4
QZ EN 303 A P. 18,00

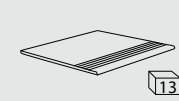

Gradino 30x30
QZ GN 303 P. 11,00

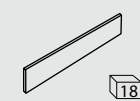

Battiscopa 7x30
QZ BN 223 P. 4,00

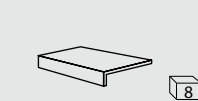

Elle inc. 15x30x4
QZ EN 223 A P. 18,00

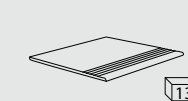

Gradino 30x30
QZ GN 223 P. 11,00

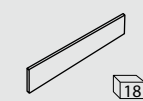

Battiscopa 7x30
QZ BN 913 P. 4,00

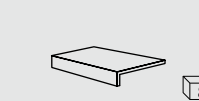

Elle inc. 15x30x4
QZ EN 913 A P. 18,00

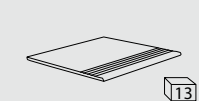

Gradino 30x30
QZ GN 913 P. 11,00

GRES PORCELLANATO A MASSA COLORATA - CLASSIFICAZIONE SECONDO NORME EN 14411 (ISO 13006) ALLEGATO G GRUPPO BIa
FULL BODY COLORED PORCELAIN TILES - CLASSIFICATION IN ACCORDANCE WITH EN 14411 (ISO 13006) ANNEX G GROUP BIa



F.to nominale Nominal size	F.to reale (mm) Work size (mm)	Spessore Thickness	Pz/Scatola Pcs/Box	Mq/Scatola Sqm/Box	Kg/Scatola Kg/Box	Scatole/Imballo Box/Packing	Mq totali Sqm total	Kg totali Kg total
30x60 / 12"x24"	297x596	9	6	1,08	20,50	40	43,20	840
30x30 / 12"x12"	-	9	13	1,17	25,80	40	46,80	1044
15x30 / 6"x12"	-	9	22	1,00	21,50	70	70,00	1517
15x15 / 6"x6"	-	9	44	1,00	21,50	70	70,00	1517

I pezzi speciali, per effetto delle lavorazioni, possono presentare variazioni di tonalità. Due to working process, special trims may show variations in tonality.
L'unità minima di vendita per tutti gli articoli (fondi, decori e pezzi speciali) è la scatola completa. The minimum sales quantity for all items (plain tiles, decorations and special trims) is one full box.
I dati relativi agli imballi sono aggiornati al momento della stampa del catalogo e pertanto possono subire variazioni nel corso del tempo.
Data referring to packaging have been update at time of printing; the actual data may be slightly different.
Approfondimenti sugli imballi a pag. 282 dell'area tecnica. Details concerning packaging available at page 282 inside technical area.

SUPREME EVO

WIDE
SUPERSIZE SLABS

LASTRE IN GRES PORCELLANATO / PORCELAIN SLABS

SUPERFICI / SURFACES



LUX+
Polished



Naturale
Natural

FORMATI / SIZES

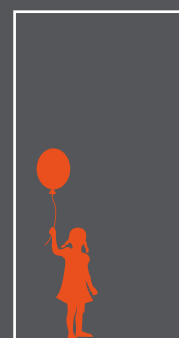

160x320
64"x128"

12 mm
6 mm



120x270
48"x108"

6 mm



120x120
48"x48"



60x120
24"x48"

9 mm



ANTIQUE WHITE



STATUARIO SUPERIOR

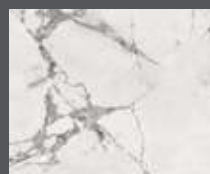

INVISIBLE SELECT



CLASSIC MARQUINIA

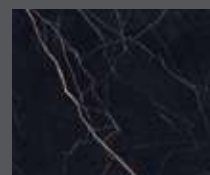

NOIR LAURENT



GREY AMANI



SUPREME EVO ANTIQUE WHITE 60X120 LUX+ / 160X320
REBEL BRASS 60X120

WIDE
SUPERSIZE SLABS



SUPREME EVO INVISIBLE SELECT LUX* 120x120

ANTIQUE WHITE

±12 mm

163,5x323 LUX+ NAT. - SLAB A	0004697	M. 230,00
163,5x323 LUX+ NAT. - SLAB B	0004698	M. 230,00
163,5x323 NAT. - SLAB A	0004695	M. 200,00
163,5x323 NAT. - SLAB B	0004696	M. 200,00

±6 mm

* 160x320 LUX+	0003532	M. 220,00
* 120x270 LUX+	0004192	M. 168,00

±9 mm









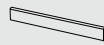

120x120 LUX+	0003542	M. 138,00
60x120 LUX+	0003544	M. 88,00

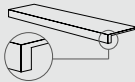
* Fino ad esaurimento scorte l'art. verrà consegnato a spessore 7 mm.
The item will be delivered 7 mm thick until stocks are exhausted.

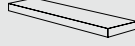

160x320

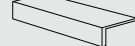
±9 mm

	BATTISCOPA		5,5x120
	LUX+ RETT.	0004913	P. 12,50
	GRADONE PLUS		32x120x4,5x2
	LUX+ RETT.	0004918	P. 179,00
	ANGOLARE PLUS SX		32x120x4,5x2
	LUX+ RETT.	0004923	P. 206,00
	ANGOLARE PLUS DX		32x120x4,5x2
	LUX+ RETT.	0004928	P. 206,00
	GRADONE JOLLY		40x120x20
	LUX+ RETT.	0004933	P. 179,00

160x320

STATUARIO SUPERIOR

±12 mm

163,5x323 LUX+ NAT. - SLAB A	0003786	M. 230,00
163,5x323 LUX+ NAT. - SLAB B	0003861	M. 230,00
163,5x323 NAT. - SLAB A	0003774	M. 200,00
163,5x323 NAT. - SLAB B	0003864	M. 200,00

±6 mm







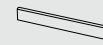

* 160x320 LUX+	0004176	M. 220,00
* 160x320 RET.	0003846	M. 168,00
* 120x270 LUX+	0004188	M. 168,00

±9 mm

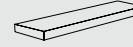
120x120 LUX+	0004198	M. 138,00
60x120 LUX+	0004203	M. 88,00

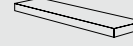
* Fino ad esaurimento scorte l'art. verrà consegnato a spessore 7 mm.
The item will be delivered 7 mm thick until stocks are exhausted.

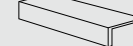
±9 mm

	BATTISCOPA		5,5x120
	LUX+ RETT.	0004909	P. 12,50
	GRADONE PLUS		32x120x4,5x2
	LUX+ RETT.	0004914	P. 179,00
	ANGOLARE PLUS SX		32x120x4,5x2
	LUX+ RETT.	0004919	P. 206,00
	ANGOLARE PLUS DX		32x120x4,5x2
	LUX+ RETT.	0004924	P. 206,00
	GRADONE JOLLY		40x120x20
	LUX+ RETT.	0004929	P. 179,00

SUPREME EVO

WIDE
SUPERSIZE SLABS



LASTRE IN GRES PORCELLANATO
PORCELAIN SLABS

INVISIBLE SELECT

± 12 mm

163,5x323 LUX+ NAT **0003789** M. 230,00

163,5x323 NAT **0003777** M. 200,00

± 6 mm

* **160x320** LUX+ **0004177** M. 220,00

* **160x320** RET **0003847** M. 168,00

* **120x270** LUX+ **0004189** M. 168,00









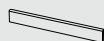

± 9 mm

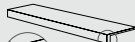
120x120 LUX+ **0004199** M. 138,00

60x120 LUX+ **0004204** M. 88,00

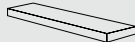
* Fino ad esaurimento scorte l'art. verrà consegnato a spessore 7 mm.
The item will be delivered 7 mm thick until stocks are exhausted.

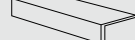
± 9 mm

	BATTISCOPIA		5,5x120
	LUX+ RETT.	0004910	P. 12,50
	GRADONE PLUS		32x120x4,5x2
	LUX+ RETT.	0004915	P. 179,00
	ANGOLARE PLUS SX		32x120x4,5x2
	LUX+ RETT.	0004920	P. 206,00
	ANGOLARE PLUS DX		32x120x4,5x2
	LUX+ RETT.	0004925	P. 206,00
	GRADONE JOLLY		40x120x20
	LUX+ RETT.	0004930	P. 179,00

160x320

MARBLE

CLASSIC MARQUINIA

± 12 mm

163,5x323
LUX+ NAT. - SLAB A **0003788** M. 230,00

163,5x323
LUX+ NAT. - SLAB B **0003863** M. 230,00

163,5x323
NAT. - SLAB A **0003776** M. 200,00

163,5x323
NAT. - SLAB B **0003866** M. 200,00

± 6 mm

* **160x320** LUX+ **0004178** M. 220,00

* **160x320** RET. **0003848** M. 168,00

* **120x270** LUX+ **0004190** M. 168,00









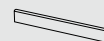

± 9 mm

120x120 LUX+ **0004200** M. 138,00

60x120 LUX+ **0004205** M. 88,00

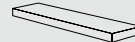
* Fino ad esaurimento scorte l'art. verrà consegnato a spessore 7 mm.
The item will be delivered 7 mm thick until stocks are exhausted.

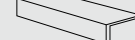
± 9 mm

	BATTISCOPIA		5,5x120
	LUX+ RETT.	0004911	P. 12,50
	GRADONE PLUS		32x120x4,5x2
	LUX+ RETT.	0004916	P. 179,00
	ANGOLARE PLUS SX		32x120x4,5x2
	LUX+ RETT.	0004921	P. 206,00
	ANGOLARE PLUS DX		32x120x4,5x2
	LUX+ RETT.	0004926	P. 206,00
	GRADONE JOLLY		40x120x20
	LUX+ RETT.	0004931	P. 179,00

160x320



160x320

NOIR LAURENT

±6 mm

* 160x320 LUX+	0002479	M. 220,00
** 120x270 LUX+	0005032	M. 168,00

±9 mm

* 120x120 LUX+	0002508	M. 138,00
* 60x120 LUX+	0002511	M. 88,00

* Fino ad esaurimento scorte l'art. verrà consegnato a spessore 7 mm.
The item will be delivered 7 mm thick until stocks are exhausted.
** Fino ad esaurimento scorte l'art. verrà consegnato nel formato 120x240 con spessore 7 mm.
The item will be delivered 7 mm thick 120x240 size until stocks are exhausted.

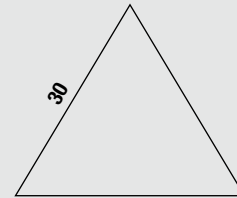





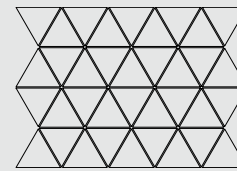



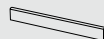

* 0002514
TRIANGOLO 30 NOIR LAURENT LUX+ RETT.
M. 319,00  = 0,54 mq

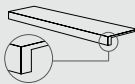
34x26

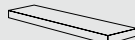

* 0002528
MOS. TRIANGOLI NOIR LAURENT LUX+
M. 419,00 

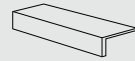
±9 mm

	* BATTISCOPIA		5,5x120
	LUX+ RETT.	0002516	P. 12,50
	* GRADONE PLUS		32x120x4,5x1,5
	LUX+ RETT.	0002519	P. 179,00
	* ANGOLARE PLUS SX		32x120x4,5x1,5
	LUX+ RETT.	0002522	P. 206,00
	* ANGOLARE PLUS DX		32x120x4,5x1,5
	LUX+ RETT.	0002525	P. 206,00
	* GRADONE JOLLY		40x120x20
	LUX+ RETT.	0004553	P. 179,00

160x320

GREY AMANI

±6 mm

* 160x320 LUX+	0002480	M. 220,00
** 120x270 LUX+	0005033	M. 168,00

±9 mm

* 120x120 LUX+	0002509	M. 138,00
* 60x120 LUX+	0002512	M. 88,00

* Fino ad esaurimento scorte l'art. verrà consegnato a spessore 7 mm.
The item will be delivered 7 mm thick until stocks are exhausted.
** Fino ad esaurimento scorte l'art. verrà consegnato nel formato 120x240 con spessore 7 mm.
The item will be delivered 7 mm thick 120x240 size until stocks are exhausted.

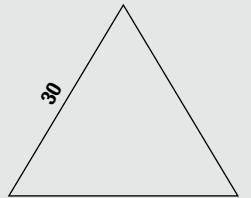





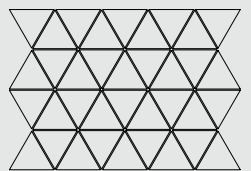



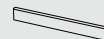

* 0002515
TRIANGOLO 30 GREY AMANI LUX+ RETT.
M. 319,00  = 0,54 mq

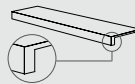
34x26

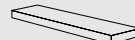

* 0002529
MOS. TRIANGOLI GREY AMANI LUX+
M. 419,00 

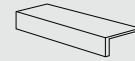
±9 mm

	* BATTISCOPIA		5,5x120
	LUX+ RETT.	0002517	P. 12,50
	* GRADONE PLUS		32x120x4,5x1,5
	LUX+ RETT.	0002520	P. 179,00
	* ANGOLARE PLUS SX		32x120x4,5x1,5
	LUX+ RETT.	0002523	P. 206,00
	* ANGOLARE PLUS DX		32x120x4,5x1,5
	LUX+ RETT.	0002526	P. 206,00
	* GRADONE JOLLY		40x120x20
	LUX+ RETT.	0004554	P. 179,00

160x320

O1.1 2 colori

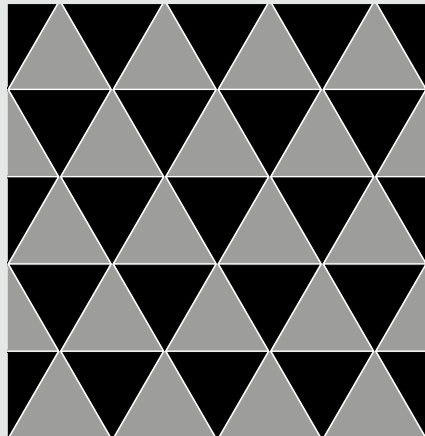

COLOR 1 50% ■
COLOR 2 50% ■

O1.2 2 colori

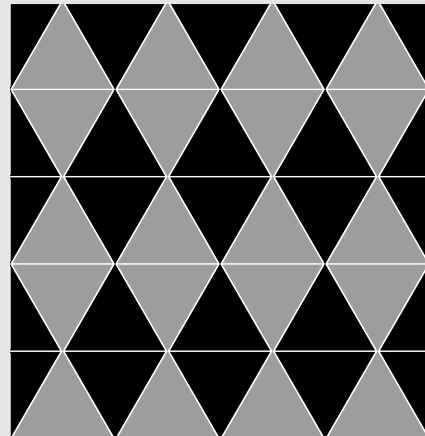

COLOR 1 50% ■
COLOR 2 50% ■

O1.3 2 colori

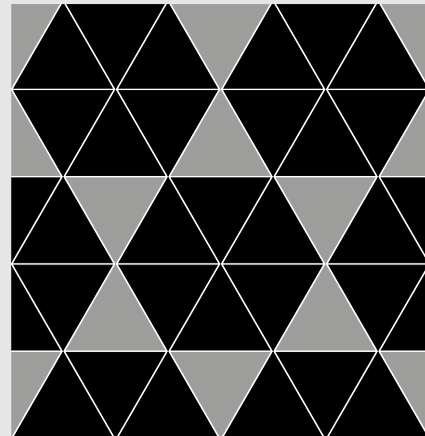

COLOR 1 75% ■
COLOR 2 25% ■

O1.4 2 colori

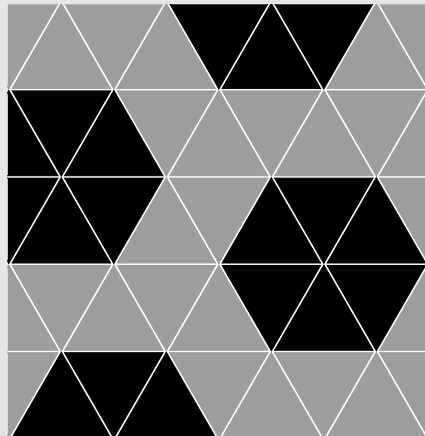

COLOR 1 57% ■
COLOR 2 43% ■

O1.5 3 colori

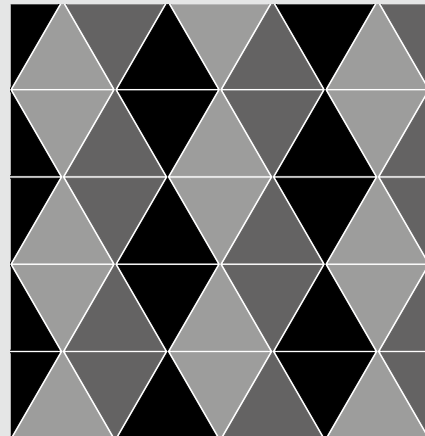

COLOR 1 33,33% ■ COLOR 3 33,33% ■
COLOR 2 33,33% ■

O1.6 3 colori

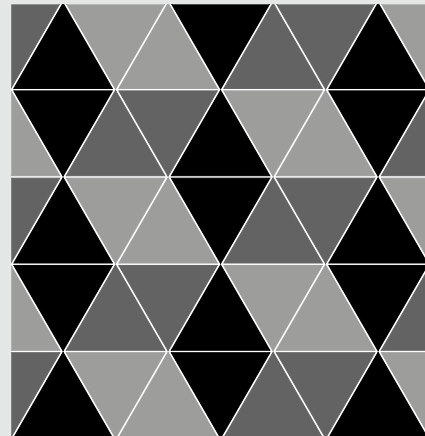

COLOR 1 33,33% ■ COLOR 3 33,33% ■
COLOR 2 33,33% ■

O1.7 3 colori

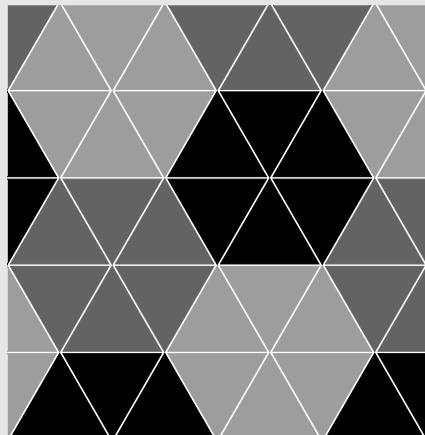

COLOR 1 33,33% ■ COLOR 3 33,33% ■
COLOR 2 33,33% ■

O1.8 4 colori

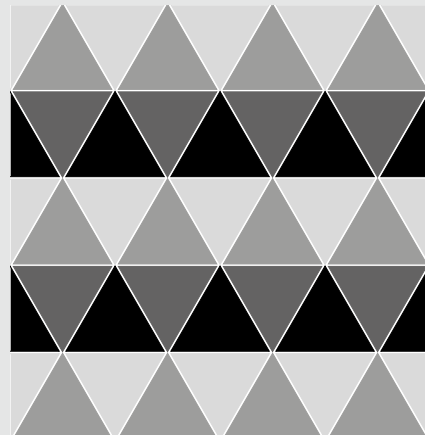

COLOR 1 25% ■ COLOR 3 25% ■
COLOR 2 25% ■ COLOR 4 25% ■

O2 2 colori

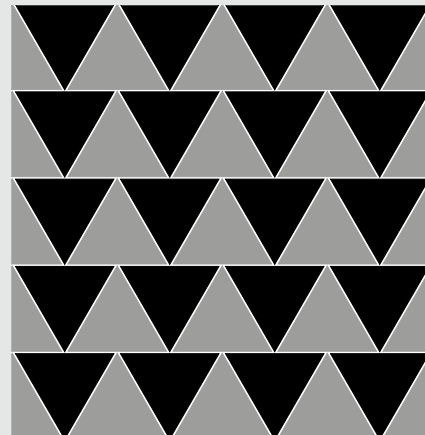

COLOR 1 50% ■
COLOR 2 50% ■



SUPREME BLACK DELUXE LUX* TRIANGOLO 30
COZY HONEY TRIANGOLO 30

0,5x120	0000086	MATITA ALLUMINIO	P. 20,90	4	
0,5x120	0000087	MATITA ALLUMINIO WHITE	P. 34,90	4	
0,5x120	0000088	MATITA ALLUMINIO BLACK	P. 34,90	4	
0,5x120	0000556	MATITA ALLUMINIO RAME	P. 34,90	4	
0,5x120	0000557	MATITA ALLUMINIO BRONZO	P. 34,90	4	

Articoli realizzati in alluminio per l'uso a parete, adatti a raccordare piastrelle di diverso spessore (9 mm / 7 mm).

Aluminium strip for use between wall tiles of different thicknesses (9 mm / 7 mm).

LASTRE IN GRES PORCELLANATO - CLASSIFICAZIONE SECONDO NORME EN 14411 (ISO 13006) ALLEGATO G GRUPPO B1a
PORCELAIN SLABS - CLASSIFICATION IN ACCORDANCE WITH EN 14411 (ISO 13006) ANNEX G GROUP B1a



F.to nominale Nominal size	F.to reale (mm) Work size (mm)	Spessore Thickness	Tipologia imballo Type of packing	Lastre/Imballo Slabs/Packing	Pz/Imballo Pcs/Packing	Mq/Scatola Sqm/Box	Kg/Scatola Kg/Box	Scatole/Imballo Box/Packing	Mq totali Sqm total	Kg/Imballo Kg/Packing	Kg totali Kg total	Prezzo imballo Packing Price
163,5x323 nat	1635x3230	12mm	Cassa Crate	10	-	-	-	-	51,20	139	1660	€ 130,00
163,5x323 lux*	1635x3230	12mm	Cassa Crate	9	-	-	-	-	46,08	139	1508	€ 130,00
163,5x323 nat/lux*	1635x3230	12mm	Cavalletto container legno A - frame Container Rack pallet wood A - frame	22	-	-	-	-	112,64	180	3524	€ 235,00
163,5x323 nat/lux*	1635x3230	12mm	Cavalletto container metallo A - frame Container Rack pallet metal A - frame	22	-	-	-	-	112,64	180	3524	€ 400,00
160x320 rett/lux*	1596,5x3195	6 mm	Cassa Crate	14	-	-	-	-	71,68	139	1.214	€ 130,00
			Cavalletto container Container Rack pallet	36	-	-	-	-	184,32	180	2.945	€ 235,00
120x270 / 48"x108" lux*	1194x2700	6 mm	Cassa Crate	18	-	-	-	-	58,32	112	987	€ 115,00
			Cavalletto Rack pallet	36	-	-	-	-	116,64	115	1.865	€ 135,00
			Cavalletto container Container Rack pallet	36	-	-	-	-	116,64	130	1.880	€ 210,00
120x120 / 48"x48" lux*	1194x1194	9 mm	Pallet con sponde Pallet with sides	36	2	2,88	56,16	18	51,84	40	1.051	-
60x120 / 48"x48" lux*	596x1194	9 mm	Pallet	60	2	1,44	28,00	30	43,20	20	860	-

I pezzi speciali, per effetto delle lavorazioni, possono presentare variazioni di tonalità. Due to working process, special trims may show variations in tonality.
L'unità minima di vendita per tutti gli articoli (fondi, decori e pezzi speciali) è la scatola completa. The minimum sales quantity for all items (plain tiles, decorations and special trims) is one full box.
I dati relativi agli imballi sono aggiornati al momento della stampa del catalogo e pertanto possono subire variazioni nel corso del tempo.
Data referring to packaging have been update at time of printing; the actual data may be slightly different.
Approfondimenti sugli imballi a pag. 282 dell'area tecnica. Details concerning packaging available at page 282 inside technical area.

SUPREME EVO

MULTIPLE SENSATIONS

WIDE
SUPERSIZE SLABS

MULTIPLE SENSATIONS è la materioteca di FLAVIKER, un contenitore di materie diverse sapientemente combinate insieme per dare vita ad atmosfere sorprendenti ed in linea con le principali tendenze del design contemporaneo.

MULTIPLE SENSATIONS from FLAVIKER is a collection of different materials which can be combined to create striking and original atmospheres in line with the latest trends in contemporary design.

SUPREME EVO

REBEL

HYPER

NORDIK WOOD

COZY



ANTIQUÉ WHITE



STATUARIO SUPERIOR



INVISIBLE SELECT



CLASSIC MARQUINIA



NOIR LAURENT



GREY AMANI

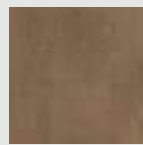

BRASS



SILVER

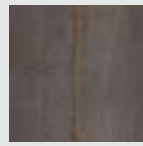

LEAD



WHITE

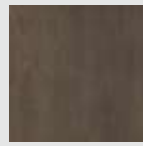

BRONZE

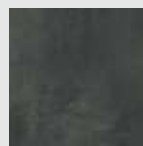

NIGHT

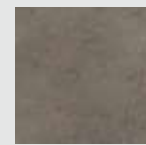

TAUPE

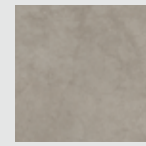

GREY



TAUPE

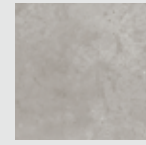

SILVER

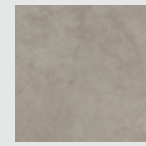

GREY

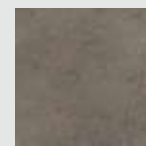

TAUPE



GOLD

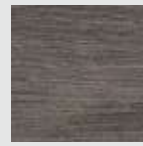

SMOKED



SMOKED



SAND



GOLD

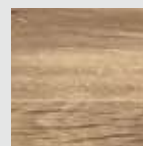

GOLD



HAVANA

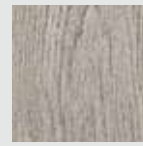

BARK



BARK

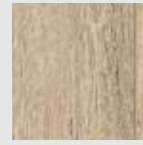

HONEY



BROWN

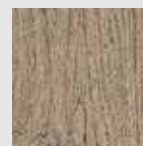

BROWN



SUPREME EVO NOIR LAURENT,
COZY BROWN



SUPREME EVO INVISIBLE SELECT,
REBEL SILVER, REBEL BRONZE



REBEL LEAD,
SUPREME EVO STATUARIO SUPERIOR



SUPREME EVO INVISIBLE SELECT,
COZY BARK

SUPREME

WIDE
SUPERSIZE SLABS

LASTRE IN GRES PORCELLANATO / PORCELAIN SLABS

SUPERFICI / SURFACES



LUX+
Polished



Naturale
Natural

FORMATI / SIZES

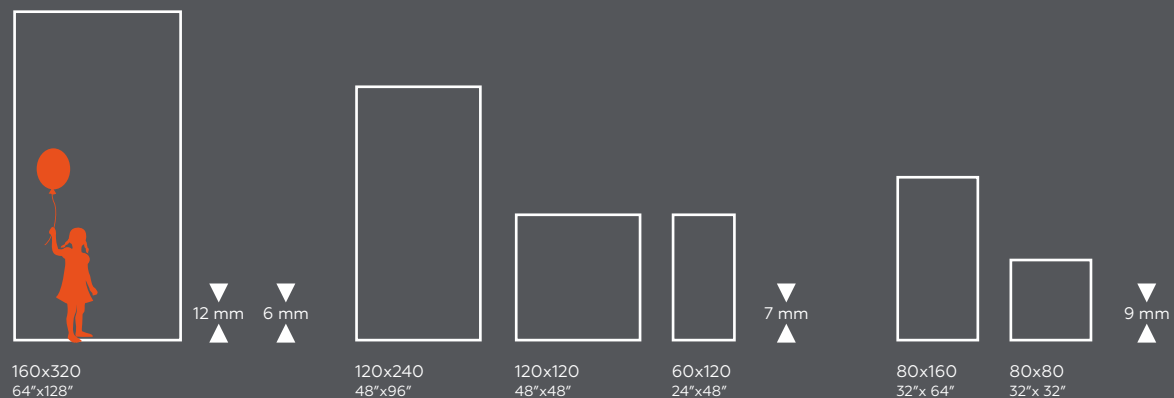

STATUARIO VENATO



EXOTIC BROWN



BLACK DELUXE



PURE STATUARIO



ONYX PRESTIGE



CALACATTA EXTRA



SUPREME STATUARIO VENATO LUX+ 120x240
HANGAR 120x120

SUPREME

WIDE
SUPERSIZE SLABS

LASTRE IN GRES PORCELLANATO
PORCELAIN SLABS



SUPREME CALACATTA EXTRA LUX+ 120x240, 120x120
STILL NO_W SAND 120x240



SUPREME PURE STATUARIO LUX+ 160X320
HANGAR SMOKE 120X240
SUPREME PURE STATUARIO LUX+ 160X160, TRIANGOLO 30, TRIANGOLO BLACK DELUXE LUX+
HANGAR SMOKE TRIANGOLO 30

STATUARIO VENATO

± 6 mm

* 160x320 LUX+ 0002481 M. 220,00

* 160x320 RETT. 0002756 M. 168,00









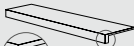

± 7 mm

120x240 LUX+ 0002497 M. 168,00

120x120 LUX+ 0002510 M. 138,00

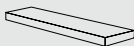
60x120 LUX+ 0002513 M. 88,00

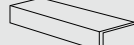
* Fino ad esaurimento scorte l'art. verrà consegnato a spessore 7 mm.
The item will be delivered 7 mm thick until stocks are exhausted.

		± 7 mm	
	BATTISCOPA		5,5x120
	LUX+ RETT.	0002518	P. 12,50
	GRADONE PLUS		32x120x4,5x1,5
	LUX+ RETT.	0002521	P. 179,00
	ANGOLARE PLUS SX		32x120x4,5x1,5
	LUX+ RETT.	0002524	P. 206,00
	ANGOLARE PLUS DX		32x120x4,5x1,5
	LUX+ RETT.	0002527	P. 206,00
	GRADONE JOLLY		40x120x20
	LUX+ RETT.	0004555	P. 179,00

160x320



160x320

EXOTIC BROWN

± 6 mm

* 160x320 LUX+ 0000399 M. 220,00

± 7 mm

120x240 LUX+ 0000405 M. 168,00

120x120 LUX+ 0000408 M. 138,00

* Fino ad esaurimento scorte l'art. verrà consegnato a spessore 7 mm.
The item will be delivered 7 mm thick until stocks are exhausted.

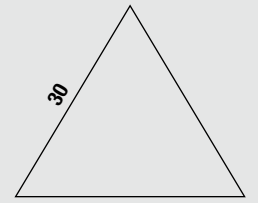





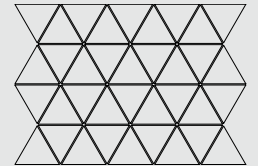



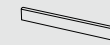

0000411 ± 7 mm
TRIANGOLO 30 EXOTIC BROWN LUX+ RETT.
M. 319,00  = 0,54 mq

34x26

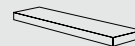

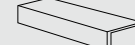
0000994 ± 7 mm
MOS. TRIANGOLI EXOTIC BROWN LUX+
M. 419,00 

		± 7 mm	
	BATTISCOPA		5,5x120
	LUX+ RETT.	0000936	P. 12,50
	GRADONE PLUS		32x120x4,5x1,5
	LUX+ RETT.	0000939	P. 179,00
	ANGOLARE PLUS SX		32x120x4,5x1,5
	LUX+ RETT.	0000942	P. 206,00
	ANGOLARE PLUS DX		32x120x4,5x1,5
	LUX+ RETT.	0000945	P. 206,00
	GRADONE JOLLY		40x120x20
	LUX+ RETT.	0004548	P. 179,00

BLACK DELUXE

✂ 6 mm

* 160x320 LUX+ 0000401 M. 220,00

✂ 7 mm

120x240 LUX+ 0000407 M. 168,00

120x120 LUX+ 0000410 M. 138,00

60x120 LUX+ 0000935 M. 88,00

* Fino ad esaurimento scorte l'art. verrà consegnato a spessore 7 mm.
The item will be delivered 7 mm thick until stocks are exhausted.

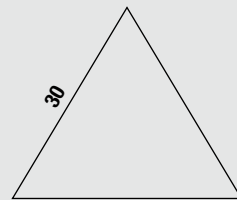

0000415 TRIANGOLO 30 BLACK DELUXE LUX+ RETT. ✂ 7 mm
M. 319,00 14 = 0,54 mq

34x26

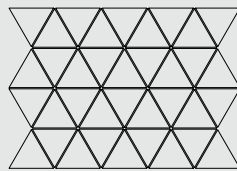

0000998 MOS. TRIANGOLI BLACK DELUXE LUX+ ✂ 7 mm
M. 419,00 5

			✂ 7 mm
	BATTISCOPA		5,5x120
	LUX+ RETT.	0000938	P. 12,50
	GRADONE PLUS		32x120x4,5x1,5
	LUX+ RETT.	0000941	P. 179,00
	ANGOLARE PLUS SX		32x120x4,5x1,5
	LUX+ RETT.	0000944	P. 206,00
	ANGOLARE PLUS DX		32x120x4,5x1,5
	LUX+ RETT.	0000947	P. 206,00
	GRADONE JOLLY		40x120x20
	LUX+ RETT.	0004552	P. 179,00

160x320

PURE STATUARIO

✂ 6 mm

* 160x320 LUX+ 0000371 M. 220,00

✂ 7 mm

120x240 LUX+ 0000383 M. 168,00

120x120 LUX+ 0000389 M. 138,00

✂ 9 mm

* 80x160 RETT. 0000735 M. 102,00

* 80x80 LUX+ 0000718 M. 88,00

* 80x80 RETT. 0000739 M. 70,00

* Fino ad esaurimento scorte l'art. verrà consegnato a spessore 7 mm.
The item will be delivered 7 mm thick until stocks are exhausted.

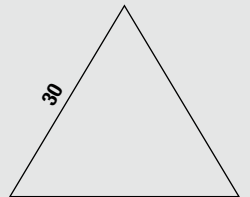

0000413 TRIANGOLO 30 PURE STATUARIO LUX+ RETT. ✂ 7 mm
M. 319,00 14 = 0,54 mq

34x26

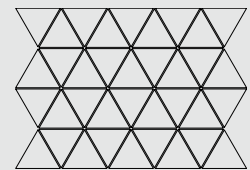

0000996 MOS. TRIANGOLI PURE STATUARIO LUX+ ✂ 7 mm
M. 419,00 5

			✂ 7 mm
	BATTISCOPA		5,5x120
	LUX+ RETT.	0000871	P. 12,50
	GRADONE PLUS		32x120x4,5x1,5
	LUX+ RETT.	0000877	P. 179,00
	ANGOLARE PLUS SX		32x120x4,5x1,5
	LUX+ RETT.	0000883	P. 206,00
	ANGOLARE PLUS DX		32x120x4,5x1,5
	LUX+ RETT.	0000889	P. 206,00
	GRADONE JOLLY		40x120x20
	LUX+ RETT.	0004550	P. 179,00

160x320

ONYX PRESTIGE

± 6 mm

* 160x320 LUX+ 0000400 M. 220,00

± 7 mm

120x240 LUX+ 0000406 M. 168,00

120x120 LUX+ 0000409 M. 138,00

* Fino ad esaurimento scorte l'art. verrà consegnato a spessore 7 mm.
The item will be delivered 7 mm thick until stocks are exhausted.

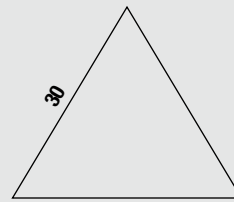

0000414 TRIANGOLO 30 ONYX PRESTIGE LUX+ RETT. ± 7 mm
M. 319,00 14 = 0,54 mq

34x26

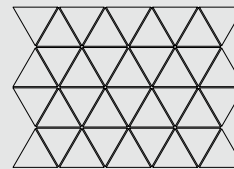

0000997 MOS. TRIANGOLI ONYX PRESTIGE LUX+ ± 7 mm
M. 419,00 5

	BATTISCOPA 6	5,5x120
	LUX+ RETT. 0000937	P. 12,50
	GRADONE PLUS 1	32x120x4,5x1,5
	LUX+ RETT. 0000940	P. 179,00
	ANGOLARE PLUS SX 1	32x120x4,5x1,5
	LUX+ RETT. 0000943	P. 206,00
	ANGOLARE PLUS DX 1	32x120x4,5x1,5
	LUX+ RETT. 0000946	P. 206,00
	GRADONE JOLLY 1	40x120x20
	LUX+ RETT. 0004551	P. 179,00

160x320



160x320

CALACATTA EXTRA

± 12 mm

163,5x323 LUX+ NAT. - SLAB A 0003787 M. 230,00

163,5x323 LUX+ NAT. - SLAB B 0003862 M. 230,00

163,5x323 NAT. - SLAB A 0003775 M. 200,00

163,5x323 NAT. - SLAB B 0003865 M. 200,00

± 6 mm

* 160x320 LUX+ 0000367 M. 220,00

* 160x320 rett. 0002751 M. 168,00

± 7 mm

120x240 LUX+ 0000379 M. 168,00

120x120 LUX+ 0000385 M. 138,00

± 9 mm

* 80x160 RETT. 0000732 M. 102,00

* 80x80 LUX+ 0000717 M. 88,00

* 80x80 RETT. 0000736 M. 70,00

* Fino ad esaurimento scorte l'art. verrà consegnato a spessore 7 mm.
The item will be delivered 7 mm thick until stocks are exhausted.

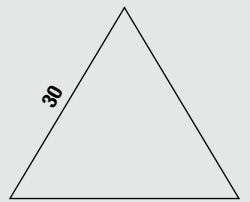

0000412 TRIANGOLO 30 CALACATTA EXTRA LUX+ RETT. ± 7 mm
M. 319,00 14 = 0,54 mq

34x26

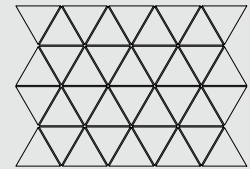

0000995 MOS. TRIANGOLI CALACATTA EXTRA LUX+ ± 7 mm
M. 419,00 5

	BATTISCOPA 6	5,5x120
	LUX+ RETT. 0000867	P. 12,50
	GRADONE PLUS 1	32x120x4,5x1,5
	LUX+ RETT. 0000873	P. 179,00
	ANGOLARE PLUS SX 1	32x120x4,5x1,5
	LUX+ RETT. 0000879	P. 206,00
	ANGOLARE PLUS DX 1	32x120x4,5x1,5
	LUX+ RETT. 0000885	P. 206,00
	GRADONE JOLLY 1	40x120x20
	LUX+ RETT. 0004549	P. 179,00

SLAB A

SLAB B



Ripresa grafica tra le diverse lastre contenuta entro una tolleranza di 3 cm.
Graphic clearance among the different slabs ranging within 3 cm.

SLAB A

SLAB B



CALACATTA EXTRA

±7 mm

SLAB A

120x240 LUX*	0001127	M. 168,00
--------------	---------	-----------

SLAB B

120x240 LUX*	0001128	M. 168,00
--------------	---------	-----------

STATUARIO VENATO

±7 mm

SLAB A

120x240 LUX*	0002500	M. 168,00
--------------	---------	-----------

SLAB B

120x240 LUX*	0002501	M. 168,00
--------------	---------	-----------



SUPREME BOOK MATCH STATUARIO VENATO 120X240 LUX* 120X120
HYPER SILVER 120X240

COMPOSIZIONI DECORATIVE DECORATIVE COMPOSITIONS

Con un occhio attento alla decorazione di interni, FLAVIKER propone composizioni grafiche realizzate a idrogetto sulle lastre ceramiche in 7 mm. Le fughe, se esaltate con stucchi a contrasto, diventano motivo decorativo. Questi soggetti sono disponibili nel formato 120x240 cm, oppure adattabili a qualsiasi misura richiesta con il servizio ON DEMAND. Il cliente dovrà fornire le esatte dimensioni della superficie da rivestire; verrà poi realizzato un disegno esecutivo con relativo preventivo. Ogni singolo pezzo che compone il soggetto verrà numerato in modo da facilitare le operazioni di posa. Fuga tra i diversi pezzi 2 mm.

With a keen eye for interior decoration, FLAVIKER offers design compositions created from waterjet-cut 7 mm thick ceramic slabs. Contrasting coloured grout can be used to enhance the joints and create a decorative pattern. These designs are available in 120x240 cm slabs or can be adapted to surfaces of any size using the ON DEMAND service. The customer will need to provide the exact dimensions of the surface to be tiled, after which a detailed drawing and quote can be made. Each piece making up the design will be numbered for ease of installation. A 2 mm joint will be maintained between the individual tiles.

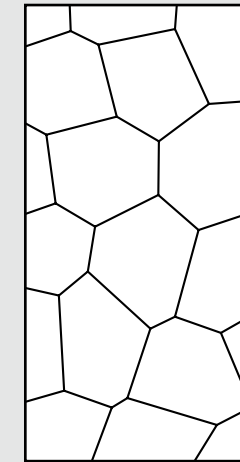

PEBBLE
COMP. 120x240

EXOTIC BROWN LUX+	0000987
BLACK DELUXE LUX+	0000991
PURE STATUARIO LUX+	0000989
ONYX PRESTIGE LUX+	0000990
CALACATTA EXTRA LUX+	0000988
STATUARIO VENATO LUX+	0003546

CP. 1.749,00

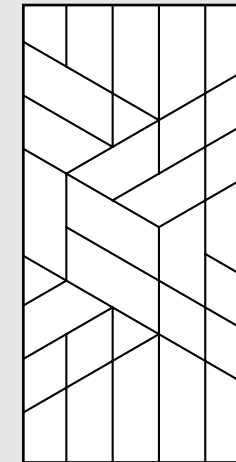

TETRIS
COMP. 120x240

EXOTIC BROWN LUX+	0000982
BLACK DELUXE LUX+	0000986
PURE STATUARIO LUX+	0000984
ONYX PRESTIGE LUX+	0000985
CALACATTA EXTRA LUX+	0000983
STATUARIO VENATO LUX+	0003643

CP. 1.749,00

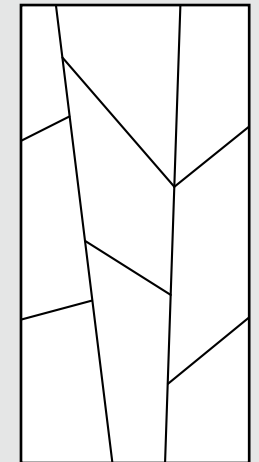

THREE
COMP. 120x240

EXOTIC BROWN LUX+	0000977
BLACK DELUXE LUX+	0000981
PURE STATUARIO LUX+	0000979
ONYX PRESTIGE LUX+	0000980
CALACATTA EXTRA LUX+	0000978
STATUARIO VENATO LUX+	0003640

CP. 1.749,00

COD. PER IL SERVIZIO SU MISURA ON DEMAND / ON DEMAND SERVICE CODE: 0000100 M. 739,00

Indicare le esatte dimensioni della parete da rivestire e i colori con cui realizzare la composizione.
Indicate the exact sizes of the wall to be tiled and the colours to use for the composition.

ESEMPI DI APPLICAZIONE EXAMPLES OF APPLICATION

COMP. 120X240

Consigliata per posa a pezzo singolo
Recommended for single-piece installation

Altezza soffitto 400 cm, Altezza posa 240 cm

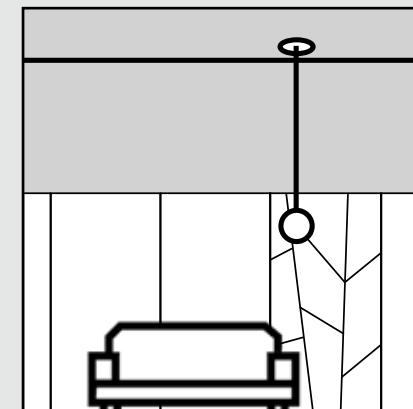

ON DEMAND

Es. Posa alt. 240 cm in tutta la parete
Ex. Laying 240 cm height throughout the length of the wall

Altezza soffitto 400 cm, Altezza posa 240 cm

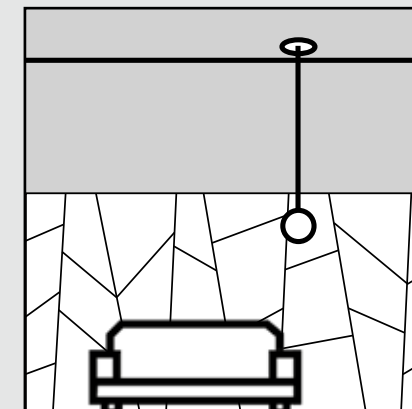

ON DEMAND

Es. Posa a tutta parete
Ex. Laying full height tiles

Altezza soffitto 400 cm, Altezza posa 400 cm

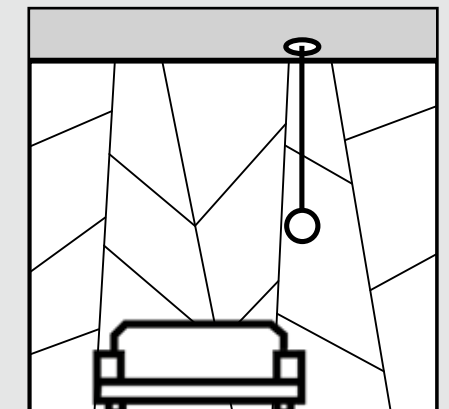

ESEMPIO DI REALIZZAZIONE ON DEMAND
EXAMPLE OF ON DEMAND SERVICE REALIZATION

SUPREME THREE ON DEMAND BLACK DELUXE LUX+
STILL NOW SAND. 120X120

O1.1 2 colori

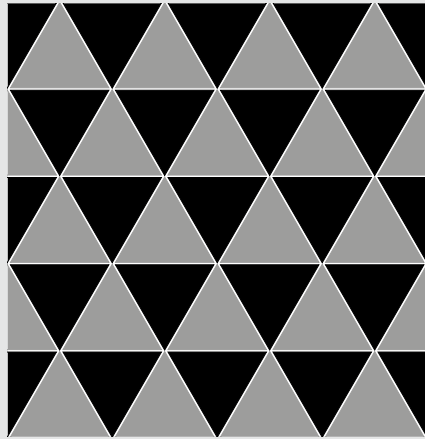

COLOR 1 50% ■
COLOR 2 50% ■

O1.2 2 colori

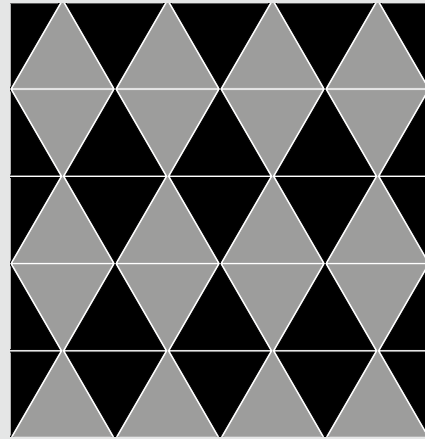

COLOR 1 50% ■
COLOR 2 50% ■

O1.3 2 colori

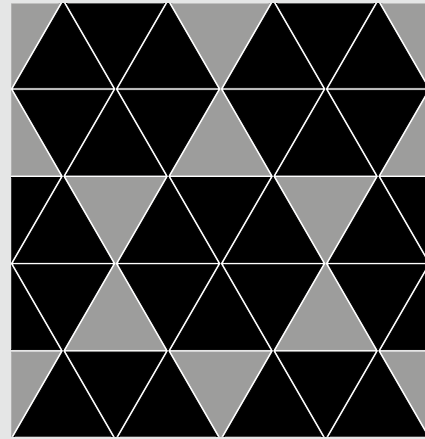

COLOR 1 75% ■
COLOR 2 25% ■

O1.4 2 colori

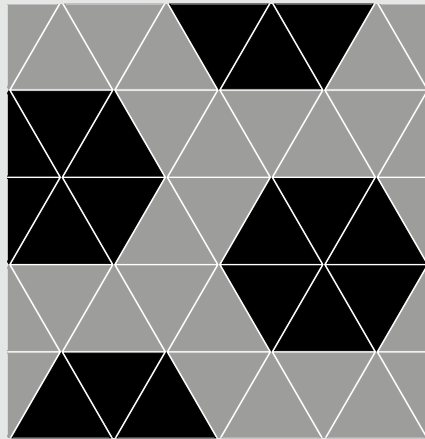

COLOR 1 57% ■
COLOR 2 43% ■

O1.5 3 colori

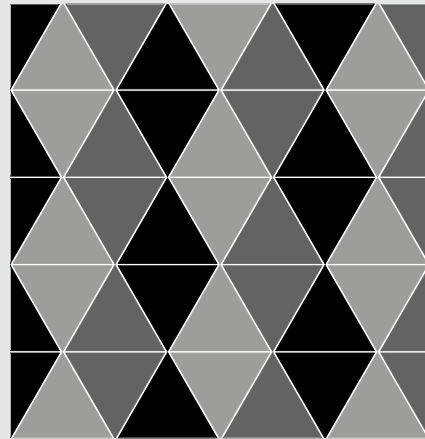

COLOR 1 33,33% ■ COLOR 3 33,33% ■
COLOR 2 33,33% ■

O1.6 3 colori

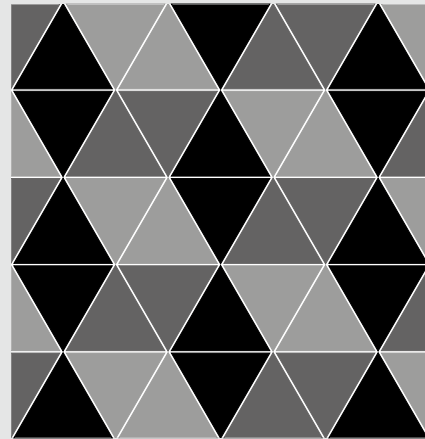

COLOR 1 33,33% ■ COLOR 3 33,33% ■
COLOR 2 33,33% ■

O1.7 3 colori

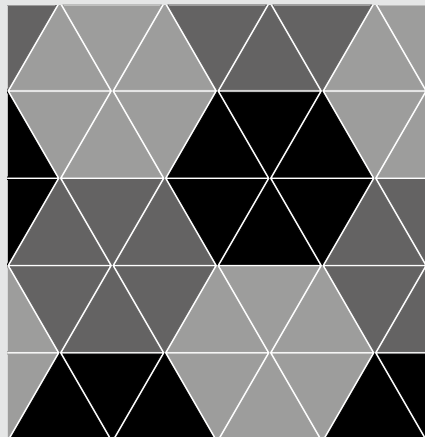

COLOR 1 33,33% ■ COLOR 3 33,33% ■
COLOR 2 33,33% ■

O1.8 4 colori

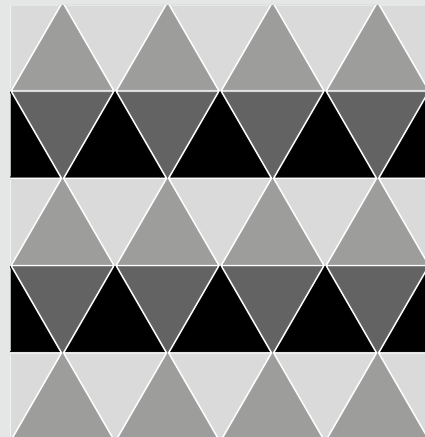

COLOR 1 25% ■ COLOR 3 25% ■
COLOR 2 25% ■ COLOR 4 25% ■

O2 2 colori

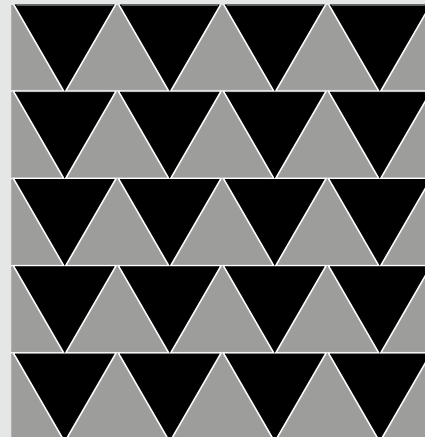

COLOR 1 50% ■
COLOR 2 50% ■

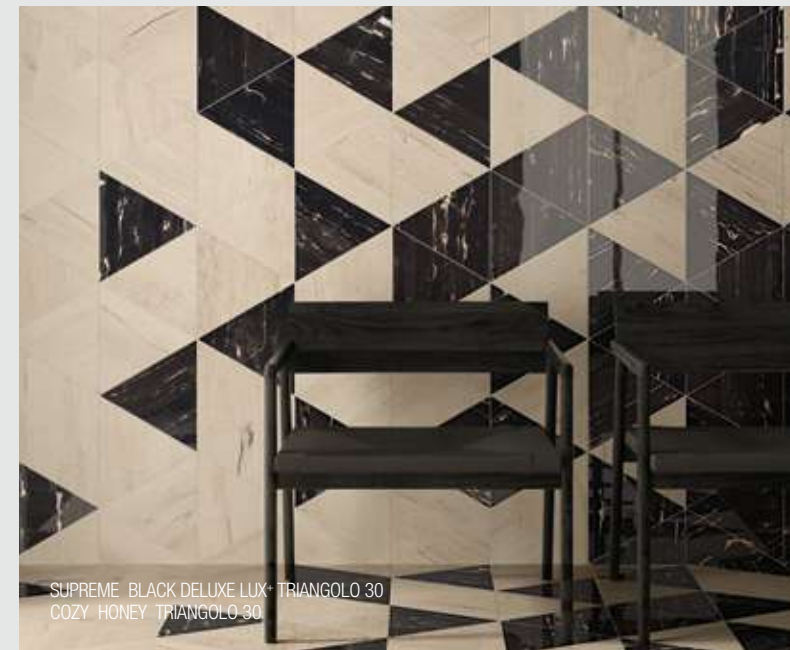

SUPREME BLACK DELUXE LUX TRIANGOLO 30
COZY HONEY TRIANGOLO 30

0,5x120	0000086	MATITA ALLUMINIO	P. 20,90	4
0,5x120	0000087	MATITA ALLUMINIO WHITE	P. 34,90	4
0,5x120	0000088	MATITA ALLUMINIO BLACK	P. 34,90	4
0,5x120	0000556	MATITA ALLUMINIO RAME	P. 34,90	4
0,5x120	0000557	MATITA ALLUMINIO BRONZO	P. 34,90	4

Articoli realizzati in alluminio per l'uso a parete, adatti a raccordare piastrelle di diverso spessore (9 mm / 7 mm).
Aluminium strip for use between wall tiles of different thicknesses (9 mm / 7 mm).

LASTRE IN GRES PORCELLANATO - CLASSIFICAZIONE SECONDO NORME EN 14411 (ISO 13006) ALLEGATO G GRUPPO B1a
PORCELAIN SLABS - CLASSIFICATION IN ACCORDANCE WITH EN 14411 (ISO 13006) ANNEX G GROUP B1a



F.to nominale Nominal size	F.to reale (mm) Work size (mm)	Spessore Thickness	Tipologia imballo Type of packing	Lastre/Imballo Slabs/Packing	Pz/Imballo Pcs/Packing	Mq/Scatola Sqm/Box	Kg/Scatola Kg/Box	Scatole/Imballo Box/Packing	Mq totali Sqm total	Kg/Imballo Kg/Packing	Kg totali Kg total	Prezzo imballo Packing Price
160x320 / 64"x128" rett/lux*	1596,5x3195	6 mm	Cassa Crate	14	-	-	-	-	71,68	139	1.214	€ 130,00
			Cavalletto container Container Rack pallet	36	-	-	-	-	184,32	180	2.945	€ 235,00
120x240 / 48"x96 lux*	1194x2390	7mm	Cavalletto Rack pallet	40	-	-	-	-	115,20	100	2.116	€ 120,00
			Cassa Crate	20	-	-	-	-	57,60	100	1.108	€ 100,00
80x160 / 32"x64" rett.	797,25x1596,5	9 mm	Cavalletto container Container Rack pallet	40	-	-	-	-	115,20	115	2.131	€ 190,00
			Cavalletto Rack pallet	44	2	2,56	50,00	22	56,32	70	1.170	€ 50,00
			Pallet con sponde Pallet with sides	44	2	2,56	50,00	22	56,32	40	1.140	€ 50,00
120x120 / 48"x48" lux*	1194x1194	7 mm	Pallet con sponde Pallet with sides	44	2	2,88	50,40	22	63,36	40	1.149	-
60x120 / 48"x48" lux*	596x1194	7 mm	Pallet	81	3	2,16	37,80	27	58,32	20	1.041	-
80x80 / 32"x32" rett/lux*	797,25x797,25	9 mm	Pallet	120	3	1,92	33,60	40	76,80	20	1.364	-

I pezzi speciali, per effetto delle lavorazioni, possono presentare variazioni di tonalità. Due to working process, special trims may show variations in tonality.
L'unità minima di vendita per tutti gli articoli (fondi, decori e pezzi speciali) è la scatola completa. The minimum sales quantity for all items (plain tiles, decorations and special trims) is one full box.
I dati relativi agli imballi sono aggiornati al momento della stampa del catalogo e pertanto possono subire variazioni nel corso del tempo.
Data referring to packaging have been update at time of printing; the actual data may be slightly different.
Approfondimenti sugli imballi a pag. 282 dell'area tecnica. Details concerning packaging available at page 282 inside technical area.

SUPREME

MULTIPLE SENSATIONS

WIDE
SUPERSIZE SLABS

MULTIPLE SENSATIONS è la materioteca di FLAVIKER, un contenitore di materie diverse sapientemente combinate insieme per dare vita ad atmosfere sorprendenti ed in linea con le principali tendenze del design contemporaneo.

MULTIPLE SENSATIONS from FLAVIKER is a collection of different materials which can be combined to create striking and original atmospheres in line with the latest trends in contemporary design.

SUPREME

COZY

STILL NO_W

HYPER

HANGAR

RIVER



STATUARIO VENATO

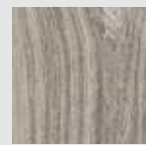

BARK

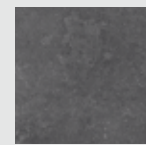

COAL

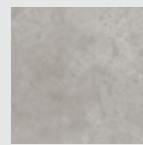

SILVER



ASH



LEAD



EXOTIC BROWN

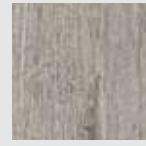

BARK

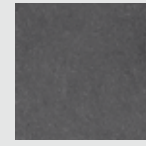

COAL

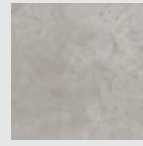

SILVER



SMOKE



ECRU



BLACK DELUXE



HONEY



SAND



TAUPE



SAND



EARTH

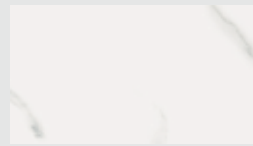

PURE STATUARIO

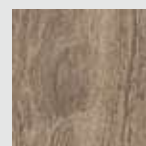

BROWN



GRAY

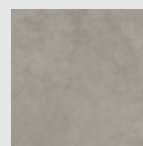

GREY



SMOKE



MOON



ONYX PRESTIGE



BROWN

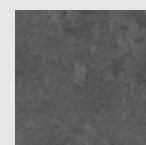

COAL

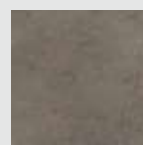

TAUPE



EARTH



CALACATTA EXTRA



HAVANA



SAND

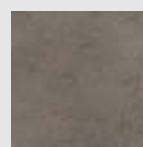

TAUPE



SAND



EARTH



SUPREME STATUARIO VENATO LUX*
HANGAR ASH



SUPREME EXOTIC BROWN LUX*
STILL NO_W COAL



SUPREME ONYX PRESTIGE LUX*
COZY BROWN



SUPREME CALACATTA EXTRA LUX*
COZY HONEY

SUPREME

GRES PORCELLANATO A MASSA COLORATA / FULL BODY COLORED PORCELAIN TILES

SUPERFICI / SURFACES



Naturale
Natural



Anticato
Antiqued



LUX^{*}
Polished

FORMATI / SIZES



60x120
24"x48"



30x120
12"x48"



60x60
24"x24"



30x60
12"x24"



10x30
4"x12"



9 mm



GOLDEN CALACATTA



ONYX PRESTIGE



EXOTIC BROWN



SILVER DREAM



ROYAL STATUARIO



EXOTIC BROWN LUX^{*} 30X120 / 60X120

SUPREME

GRES PORCELLANATO A MASSA COLORATA
FULL BODY COLORED PORCELAIN TILES



ROYAL STATUARIO LUX* 60X60



GOLDEN CALACATTA ANTICATO RETT. 60X120
GOLDEN CALACATTA ANTICATO RETT. 60X60
LISTONE RAME 5X60

ONYX PRESTIGE ANTICATO RETT. 60X120

GOLDEN CALACATTA

ONYX PRESTIGE



60x120

60x120

R: Rettificato | Rectified
P: Anticato | Aged
L: Lux*

R: Rettificato | Rectified
P: Anticato | Aged
L: Lux*

51x29,2
MOSAICO HEXAGON
RETT. (Ant) M. 120,00

60x120 MIX SIZES RETT.
2 pcs/box 2 pcs/box 2 pcs/box
30x120 - 20x120 - 10x120

60x120 MIX FLOOR
1 pcs/box 1 pcs/box 1 pcs/box
60x120 - 60x80 - 60x40

30x30
MOSAICO RETT.
(Ant./Lux*)
M. 249,00

30x30
MOSAICO 5x5
RETT. (Ant.)
M. 104,00

60x120
SP 6113 P M. 80,00
SP 6113 L M. 88,00

30x120
SP 3113 P M. 80,00
SP 3113 L M. 88,00

SP MIP 13 M. 88,00
(Anticato)

SP FLO 13 MIX FLOOR ANTICATO M. 92,00

60x60
SP 6013 R M. 53,50
SP 6013 P M. 66,00
SP 6013 L M. 76,50

30x60
SP 3613 P M. 57,50

10x30
SP 1013 P M. 76,00

51x29,2
MOSAICO HEXAGON
RETT. (Ant) M. 120,00

60x120 MIX SIZES RETT.
2 pcs/box 2 pcs/box 2 pcs/box
30x120 - 20x120 - 10x120

60x120 MIX FLOOR
1 pcs/box 1 pcs/box 1 pcs/box
60x120 - 60x80 - 60x40

30x30
MOSAICO RETT.
(Ant./Lux*)
M. 249,00

30x30
MOSAICO 5x5
RETT. (Ant.)
M. 104,00

60x120
SP 6134 P M. 80,00
SP 6134 L M. 88,00

30x120
SP 3134 P M. 80,00
SP 3134 L M. 88,00

SP MIP 34 M. 88,00
(Anticato)

SP FLO 34 MIX FLOOR ANTICATO M. 92,00

60x60
SP 6034 R M. 53,50
SP 6034 P M. 66,00
SP 6034 L M. 76,50

30x60
SP 3634 P M. 57,50

10x30
SP 1034 P M. 76,00

SP MP 341 M. 104,00
MOSAICO 5x5
RETT. (Ant.)

Battiscopa 5,5x60 P. 8,00
SP BP 136 Rett. P. 9,50

Gradone Plus 32x120x4,5x2 P. 179,00
SP RP 132 Rett. P. 179,00
SP RL 132 Rett. P. 179,00

Angolare Plus sx 32x120x4,5x2 P. 206,00
SP RS 13P (Ant.) P. 206,00

Angolare Plus sx 32x120x4,5x2 P. 206,00
SP RS 13L (Lux*) P. 206,00

Angolare Plus dx 32x120x4,5x2 P. 206,00
SP RD 13P (Ant.) P. 206,00

Angolare Plus dx 32x120x4,5x2 P. 206,00
SP RD 13L (Lux*) P. 206,00

Battiscopa 5,5x60 P. 8,00
SP BP 346 Rett. P. 9,50

Gradone Plus 32x120x4,5x2 P. 179,00
SP RP 342 Rett. P. 179,00
SP RL 342 Rett. P. 179,00

Angolare Plus sx 32x120x4,5x2 P. 206,00
SP RS 34P (Ant.) P. 206,00

Angolare Plus sx 32x120x4,5x2 P. 206,00
SP RS 34L (Lux*) P. 206,00

Angolare Plus dx 32x120x4,5x2 P. 206,00
SP RD 34P (Ant.) P. 206,00

Angolare Plus dx 32x120x4,5x2 P. 206,00
SP RD 34L (Lux*) P. 206,00

EXOTIC BROWN

SILVER DREAM



60x120

60x120

R: Rettificato | Rectified
P: Anticato | Aged
L: Lux*

R: Rettificato | Rectified
P: Anticato | Aged
L: Lux*

60x120 MIX SIZES RETT.
2 pcs/box 2 pcs/box 2 pcs/box
30x120 - 20x120 - 10x120

60x120 MIX FLOOR
1 pcs/box 1 pcs/box 1 pcs/box
60x120 - 60x80 - 60x40

51x29,2
MOSAICO HEXAGON
RETT. (Ant) **M. 120,00**

30x30
MOSAICO RETT.
(Ant./Lux*)
M. 249,00

30x30
MOSAICO 5x5
RETT. (Ant.)
M. 104,00

60x120
SP 6144 P **M. 80,00**
SP 6144 L **M. 88,00**

30x120
SP 3144 P **M. 80,00**
SP 3144 L **M. 88,00**

SP MIP 44 **M. 88,00**
(Anticato)

60x60
SP 6044 R **M. 53,50**
SP 6044 P **M. 66,00**
SP 6044 L **M. 76,50**

30x60
SP 3644 P **M. 57,50**

10x30
SP 1044 P **M. 76,00**

SP MP 441
MOSAICO 5x5
RETT. (Ant.)
M. 104,00

60x120 MIX SIZES RETT.
2 pcs/box 2 pcs/box 2 pcs/box
30x120 - 20x120 - 10x120

60x120 MIX FLOOR
1 pcs/box 1 pcs/box 1 pcs/box
60x120 - 60x80 - 60x40

51x29,2
MOSAICO HEXAGON
RETT. (Ant) **M. 120,00**

30x30
MOSAICO RETT.
(Ant./Lux*)
M. 249,00

30x30
MOSAICO 5x5
RETT. (Ant.)
M. 104,00

60x120
SP 6122 P **M. 80,00**
SP 6122 L **M. 88,00**

30x120
SP 3122 P **M. 80,00**
SP 3122 L **M. 88,00**

SP MIP 22 **M. 88,00**
(Anticato)

60x60
SP 6022 R **M. 53,50**
SP 6022 P **M. 66,00**
SP 6022 L **M. 76,50**

30x60
SP 3622 P **M. 57,50**

10x30
SP 1022 P **M. 76,00**

SP MP 221
MOSAICO 5x5
RETT. (Ant.)
M. 104,00

Battiscopa 5,5x60 **P. 8,00**
SP BP 446 Rett. **P. 8,00**
SP BL 446 Rett. **P. 9,50**

Gradone Plus 32x120x4,5x2 **P. 179,00**
SP RP 442 Rett. **P. 179,00**
SP RL 442 Rett. **P. 179,00**

Angolare Plus sx 32x120x4,5x2 **P. 206,00**
SP RS 44P (Ant.) **P. 206,00**
Angolare Plus dx 32x120x4,5x2

Angolare Plus sx 32x120x4,5x2 **P. 206,00**
SP RS 44L (Lux*) **P. 206,00**
Angolare Plus dx 32x120x4,5x2

SP RD 44P (Ant.) **P. 206,00**
SP RD 44L (Lux*) **P. 206,00**

Battiscopa 5,5x60 **P. 8,00**
SP BP 226 Rett. **P. 8,00**
SP BL 226 Rett. **P. 9,50**

Gradone Plus 32x120x4,5x2 **P. 179,00**
SP RP 222 Rett. **P. 179,00**
SP RL 222 Rett. **P. 179,00**

Angolare Plus sx 32x120x4,5x2 **P. 206,00**
SP RS 22P (Ant.) **P. 206,00**
Angolare Plus dx 32x120x4,5x2

Angolare Plus sx 32x120x4,5x2 **P. 206,00**
SP RS 22L (Lux*) **P. 206,00**
Angolare Plus dx 32x120x4,5x2

SP RD 22P (Ant.) **P. 206,00**
SP RD 22L (Lux*) **P. 206,00**

ROYAL STATUARIO



60x120

R: Rettificato | Rectified
P: Anticato | Aged
L: Lux*

60x120 MIX SIZES RETT.
2 pcs/box 2 pcs/box 2 pcs/box
30x120 - 20x120 - 10x120

60x120
SP 6110 P M. 80,00
SP 6110 L M. 88,00

30x120
SP 3110 P M. 80,00
SP 3110 L M. 88,00

SP MIP 10 M. 88,00
(Anticato)

60x120 MIX FLOOR
1 pcs/box 1 pcs/box 1 pcs/box
60x120 - 60x80 - 60x40

SP FLO 10 MIX FLOOR ANTICATO M. 92,00

60x60
SP 6010 R M. 53,50
SP 6010 P M. 66,00
SP 6010 L M. 76,50

30x60
SP 3610 P M. 57,50

10x30
SP 1010 P M. 76,00

51x29,2
MOSAICO HEXAGON
RETT. (Ant) M. 120,00

30x30
SP MO 103
MOSAICO RETT.
(Ant./Lux*)
M. 249,00

30x30
SP MP 101
MOSAICO 5x5
RETT. (Ant.)
M. 104,00

Battiscopa 5,5x60
SP BP 106 Rett. P. 8,00
SP BL 106 Rett. P. 9,50

Gradone Plus 32x120x4,5x2
SP RP 102 Rett. P. 179,00
SP RL 102 Rett. P. 179,00

Angolare Plus sx 32x120x4,5x2
SP RS 10P (Ant.) P. 206,00
Angolare Plus dx 32x120x4,5x2
SP RD 10P (Ant.) P. 206,00

Angolare Plus sx 32x120x4,5x2
SP RS 10L (Lux*) P. 206,00
Angolare Plus dx 32x120x4,5x2
SP RD 10L (Lux*) P. 206,00

DECORI / DECORS

5x120
DK DP 301 LIST. DAKOTA AVANA RESERVE P. 8,00

5x120
DK DP 131 LIST. DAKOTA NATURALE RESERVE P. 8,00

5x120
DK DP 231 LIST. DAKOTA TORTORA RESERVE P. 8,00

6x30
DK DF 301 FASCIA DAKOTA AVANA P. 13,00

6x30
DK DF 131 FASCIA DAKOTA NATURALE P. 13,00

6x30
DK DF 231 FASCIA DAKOTA TORTORA P. 13,00

5x120
AN DL 222 LIST. ASPEN GREY LUX* P. 10,00

5x120
AN DL 132 LIST. ASPEN NATURAL LUX* P. 10,00

5x120
AN DL 302 LIST. ASPEN HAVANA LUX* P. 10,00

5x60
SP DP 001 LISTONE RAME P. 33,00

5x60
SP DP 002 LISTONE NICHEL P. 33,00

8,5x8,5
BK DE 222 HEXAGON COLOR MIX4 P. 18,50

8,5x8,5
BK DE 232 HEXAGON TEXTURE MIX4 P. 18,50

0,5x120 **0000086** MATITA ALLUMINIO P. 20,90

0,5x120 **0000087** MATITA ALLUMINIO WHITE P. 34,90

0,5x120 **0000088** MATITA ALLUMINIO BLACK P. 34,90

0,5x120 **0000556** MATITA ALLUMINIO RAME P. 34,90

0,5x120 **0000557** MATITA ALLUMINIO BRONZO P. 34,90

Articoli realizzati in alluminio per l'uso a parete, adatti a raccordare piastrelle di diverso spessore (9 mm / 7 mm).

Aluminium strip for use between wall tiles of different thicknesses (9 mm / 7 mm).



60x120
SP 6122 W SUPREME FUSION COLD
M. 78,00



30x120
SP 3122 W SUPREME FUSION COLD
M. 78,00



30x120
SP DI 22 W DEC. LINE MIX COLD RETT.
P. 180,00



60x120
SP 6134 W SUPREME FUSION HOT
M. 78,00



30x120
SP 3134 W SUPREME FUSION HOT
M. 78,00



30x120
SP DI 34 W DEC. LINE MIX HOT RETT.
P. 180,00

▼
9 mm
▲

Per maggiori informazioni vedi pag. 287

For further information see page 287



SCHEMI DI POSA INSTALLATION PATTERNS

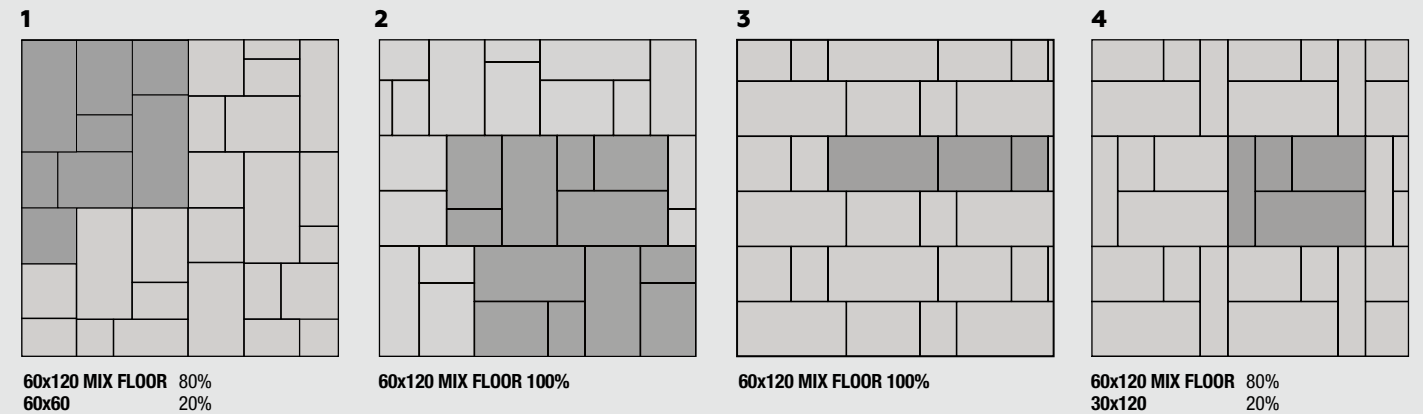

SUPREME FUSION COLD 60X120
DEC. LINE FUSION COLD MIX 30X120

GRES PORCELLANATO A MASSA COLORATA - CLASSIFICAZIONE SECONDO NORME EN 14411 (ISO 13006) ALLEGATO G GRUPPO Bia
FULL BODY COLORED PORCELAIN TILES - CLASSIFICATION IN ACCORDANCE WITH EN 14411 (ISO 13006) ANNEX G GROUP Bia



F.to nominale Nominal size	F.to reale (mm) Work size (mm)	Spessore Thickness	Tipologia imballo Type of packing	Lastre/Imballo Slabs/Packing	Pz/Imballo Pcs/Packing	Mq/Scatola Sqm/Box	Kg/Scatola Kg/Box	Scatole/Imballo Box/Packing	Mq totali Sqm total	Kg/Imballo Kg/Packing	Kg totali Kg total	Prezzo imballo Packing Price
60x120 / 24"x48" ant./lux*	596x1194	9	Pallet	60	2	1,44	28,00	30	43,20	20	860	-
60x120 / 24"x48" MIX WALL	-	9	Pallet	-	2	1,44	27,20	26	37,44	20	748	-
30x120 / 12"x48" ant./lux*	297x1194	9	Pallet	144	4	1,44	28,00	36	51,84	20	1.028	-
60x120 / 24"x48" MIX FLOOR	-	9	Pallet	52	2	1,44	28,00	26	37,44	20	748	-
60x60 / 24"x24" rett./ant./lux*	596x596	9	Pallet	120	3	1,08	21,20	40	43,20	20	868	-
30x60 / 12"x24" ant.	297x596	9	Pallet	240	6	1,08	21,20	40	43,20	20	868	-
10x30 / 4"x12" ant.	97,6x297	9	Pallet	1152	18	0,54	11,60	64	34,56	20	762	-
30x60 / 12"x24" W&P	297x596	9	Pallet	-	6	1,08	20,00	40	43,20	20	815	-
60x120 / 24"x48" W&P	596x1194	9	Pallet	-	2	1,44	26,20	26	37,44	20	722	-
30x120 / 12"x48" W&P	297x1194	9	Pallet	-	4	1,44	26,20	18	25,92	20	509	-

I pezzi speciali, per effetto delle lavorazioni, possono presentare variazioni di tonalità. Due to working process, special trims may show variations in tonality. L'unità minima di vendita per tutti gli articoli (fondi, decori e pezzi speciali) è la scatola completa. The minimum sales quantity for all items (plain tiles, decorations and special trims) is one full box. I dati relativi agli imballi sono aggiornati al momento della stampa del catalogo e pertanto possono subire variazioni nel corso del tempo. Data referring to packaging have been update at time of printing; the actual data may be slightly different. Approfondimenti sugli imballi a pag. 282 dell'area tecnica. Details concerning packaging available at page 282 inside technical area.

NORDIK WOOD

AUTO-LEVELING™
Tavola levellabile - Easy laylay

GRES PORCELLANATO / PORCELAIN TILES

SUPERFICI / SURFACES



Naturale
Natural



Grip
Antislippery

FORMATI / SIZES



26x200
10"x78"

7 mm



20x120
8"x48"



60x60
12"x48"

9 mm



30x120
12"x48"

20 mm



GOLD



BEIGE



BROWN



SMOKED



NORDIK WOOD BEIGE 26X200

NORDIK WOOD

AUTO-LEVELING™
Facile installazione - Easy laying

GRES PORCELLANATO
PORCELAIN TILES

WOOD

GOLD



±7 mm

26x200 RETT. 0003673 M. 104,00

±9 mm

20x120 RETT. 0003687 M. 70,00

GRIP R11 ±9 mm

20x120 GRIP RETT. 0004609 M. 70,00

X20 R11 ±20 mm

30x120 RETT. 0004816 M. 99,00





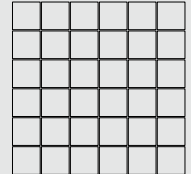



Per la serie completa vedi pag.: 248
For the complete collection see at page: 248

30x30

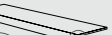

0004613 ±9 mm
MOSAICO GOLD RETT.
M. 104,00 

±9 mm

	BATTISCOPA 	6,5x120
	RETT. 0004617	P. 9,50
	GRADONE PLUS 	32x120x4,5x2
	RETT. 0004621	P. 169,00
	ANGOLARE PLUS SX 	32x120x4,5x2
	RETT. 0004625	P. 196,00
	ANGOLARE PLUS DX 	32x120x4,5x2
	RETT. 0004629	P. 196,00

NORDIK WOOD GOLD 60x120, MOSAICO T36 30x30,
NORDIK STONE BLACK 60x60, MOSAICO T36 30x30

20x120

NORDIK WOOD

AUTO-LEVELING™
Facile installazione - Easy laying

GRES PORCELLANATO
PORCELAIN TILES

BEIGE



20x120

±7 mm

26x200 RETT. **0003672** M. 104,00

±9 mm

20x120 RETT. **0003686** M. 70,00

GRIP R11 ±9 mm

20x120 GRIP RETT. **0004608** M. 70,00

X20 R11 ±20 mm

30x120 RETT. **0004815** M. 99,00





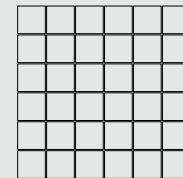

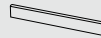

Per la serie completa vedi pag.: 248
For the complete collection see at page: 248

30x30

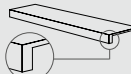

0004612 ±9 mm
MOSAICO BEIGE RETT.
M. 104,00 

±9 mm

	BATTISCOPIA 	6,5x120
	RETT. 0004616	P. 9,50
	GRADONE PLUS 	32x120x4,5x2
	RETT. 0004620	P. 169,00
	ANGOLARE PLUS SX 	32x120x4,5x2
	RETT. 0004624	P. 196,00
	ANGOLARE PLUS DX 	32x120x4,5x2
	RETT. 0004628	P. 196,00

WOOD

BROWN



20x120

±7 mm

26x200 RETT. **0003674** M. 104,00

±9 mm

20x120 RETT. **0003688** M. 70,00

GRIP R11 ±9 mm





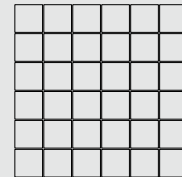



20x120 GRIP RETT. **0004610** M. 70,00

30x30

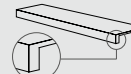

0004614 ±9 mm
MOSAICO BROWN RETT.
M. 104,00 

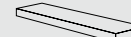
±9 mm

	BATTISCOPIA 	6,5x120
	RETT. 0004618	P. 9,50
	GRADONE PLUS 	32x120x4,5x2
	RETT. 0004622	P. 169,00
	ANGOLARE PLUS SX 	32x120x4,5x2
	RETT. 0004626	P. 196,00
	ANGOLARE PLUS DX 	32x120x4,5x2
	RETT. 0004630	P. 196,00

NORDIK WOOD

AUTO-LEVELING™
Facile installazione - Easy laying



20x120

GRES PORCELLANATO
PORCELAIN TILES

SMOKED

			±7 mm
26x200 RETT.	0003675	M. 104,00	
			±9 mm
20x120 RETT.	0003689	M. 70,00	
			±9 mm
GRIP R11			±9 mm
20x120 GRIP RETT.	0004611	M. 70,00	

30x30

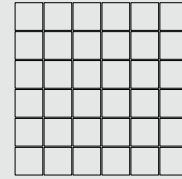

0004615 ±9 mm
MOSAICO SMOKED RETT.
M. 104,00



60X60
0005045
PALACE BEIGE / GOLD RETT.
M. 66,00

±9 mm



60X60
0005047
MANSION GOLD / BROWN RETT.
M. 66,00

±9 mm

GRES PORCELLANATO - CLASSIFICAZIONE SECONDO NORME EN 14411 (ISO 13006) ALLEGATO G GRUPPO BIa
PORCELAIN TILES - CLASSIFICATION IN ACCORDANCE WITH EN 14411 (ISO 13006) ANNEX G GROUP BIa

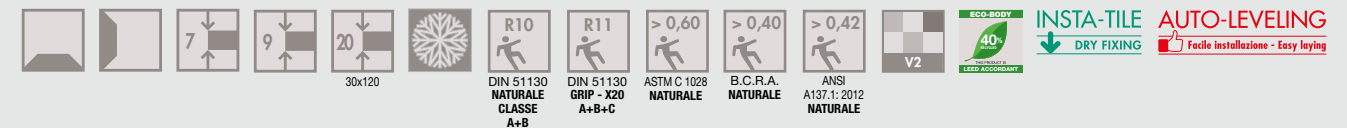

F.to nominale Nominal size	F.to reale (mm) Work size (mm)	Spessore Thickness	Tipologia imballo Type of packing	Lastre/Imballo Slabs/Packing	Pz/Imballo Pcs/Packing	Mq/Scatola SqM/Box	Kg/Scatola Kg/Box	Scatole/Imballo Box/Packing	Mq totali SqM total	Kg/Imballo Kg/Packing	Kg totali Kg total	Prezzo imballo Packing Price
26x200 / 10"x78" rett.	264,4x2000	7 mm	Cavalletto Rack Pallet	80	5	2,60	45,50	16	41,60	50	778	-
20x120 / 8"x48" rett.	199x1194	9 mm	Pallet	216	6	1,44	27,20	36	51,84	20	999	-
60x60 / 24"x24" rett.	596x596	9 mm	Pallet	120	3	1,08	21,20	40	43,20	20	868	-
30x120 / 12"x48" rett.	296x1195,5	20 mm	Pallet	72	2	0,72	32,00	36	25,92	20	1.172	-

I pezzi speciali, per effetto delle lavorazioni, possono presentare variazioni di tonalità. Due to working process, special trims may show variations in tonality.
L'unità minima di vendita per tutti gli articoli (fondi, decori e pezzi speciali) è la scatola completa. The minimum sales quantity for all items (plain tiles, decorations and special trims) is one full box.
I dati relativi agli imballi sono aggiornati al momento della stampa del catalogo e pertanto possono subire variazioni nel corso del tempo.
Data referring to packaging have been update at time of printing; the actual data may be slightly different.
Approfondimenti sugli imballi a pag. 282 dell'area tecnica. Details concerning packaging available at page 282 inside technical area.

NORDIK WOOD

MULTIPLE SENSATIONS

MULTIPLE SENSATIONS è la materioteca di FLAVIKER, un contenitore di materie diverse sapientemente combinate insieme per dare vita ad atmosfere sorprendenti ed in linea con le principali tendenze del design contemporaneo.

MULTIPLE SENSATIONS from FLAVIKER is a collection of different materials which can be combined to create striking and original atmospheres in line with the latest trends in contemporary design.

NORDIK WOOD



GOLD



BEIGE



BROWN



SMOKED

NORDIK STONE

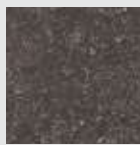

BLACK



BLACK



SAND



GREY

HYPER

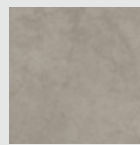

GREY



TAUPE

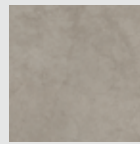

GREY

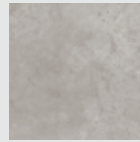

SILVER

STILL NO_W

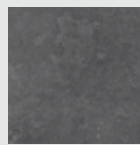

COAL



SAND

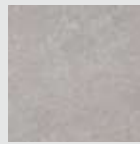

GRAY

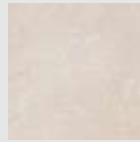

SAND

REBEL

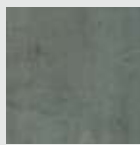

EMERALD

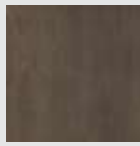

BRONZE



WHITE



SILVER



NORDIK STONE BLACK - WOOD BEIGE



NORDIK WOOD BROWN, HYPER GREY



NORDIK WOOD SMOKED, RIVER MOON, LAVABO RIVER LEAD



NORDIK WOOD GOLD, REBEL EMERALD

COZY

AUTO LEVELING™
Tutti i modelli - Tutti i tipi

GRES PORCELLANATO / PORCELAIN TILES

SUPERFICI / SURFACES

Naturale
Natural

FORMATI / SIZES

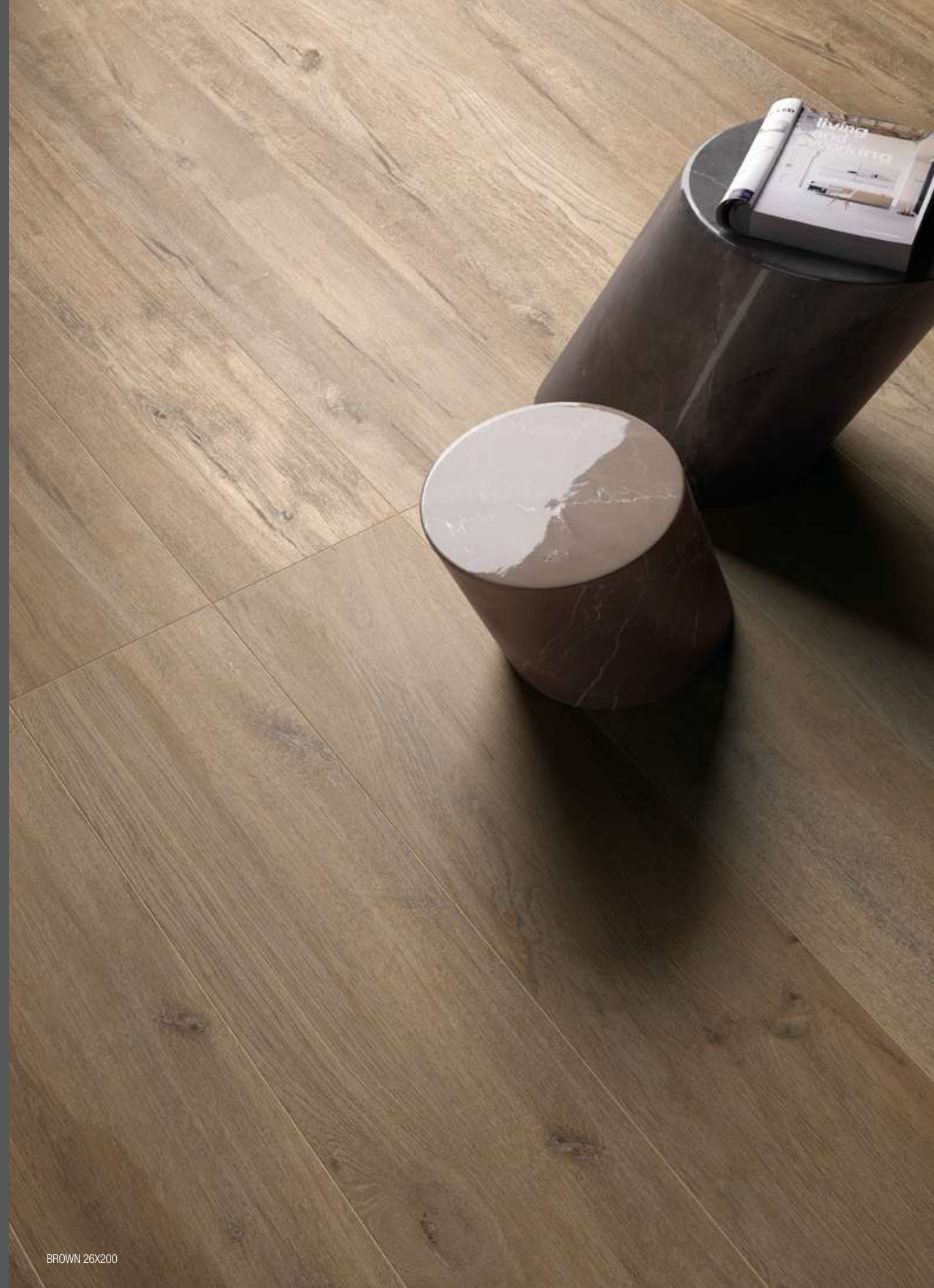
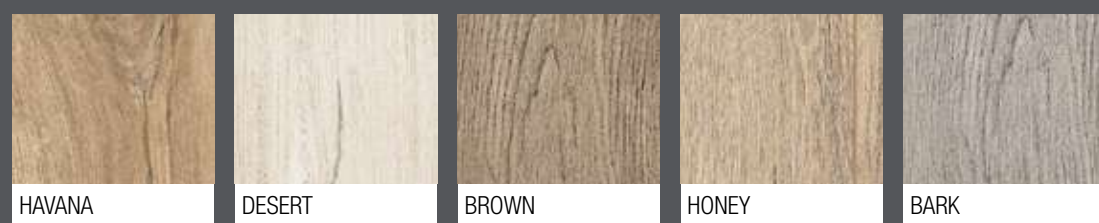
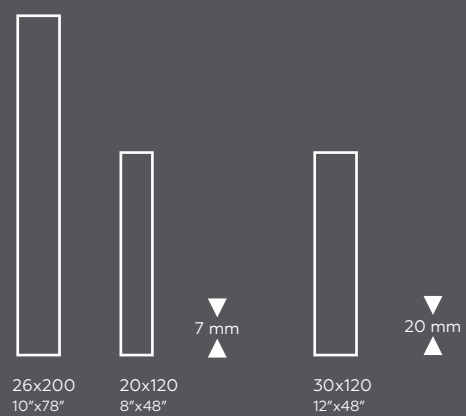

BROWN 26X200

HONEY



HONEY 26X200, GRADONE PLUS 32X120X4,5X1,5



20x120

7 mm

26x200	RETT.	0000472	M. 104,00
20x120	RETT.	0000475	M. 70,00

34x26

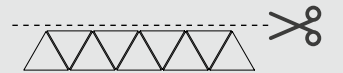
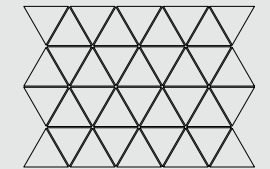



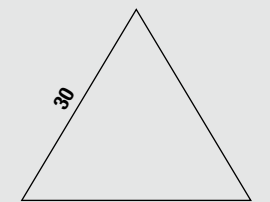





0001281
MOS. TRIANGOLI HONEY RETT.
M. 349,00 



0001112
TRIANGOLO 30 HONEY RETT.
M. 249,00  = 0,54 Mq

7 mm

	BATTISCOPA		6,5x120
	RETT.	0001264	P. 9,50
	GRADONE PLUS		32x120x4,5x1,5
	RETT.	0001268	P. 169,00
	ANGOLARE PLUS SX		32x120x4,5x1,5
	RETT.	0001272	P. 196,00
	ANGOLARE PLUS DX		32x120x4,5x1,5
	RETT.	0001276	P. 196,00

DESERT

±7 mm

26x200 RETT.	0000471	M. 104,00
20x120 RETT.	0000474	M. 70,00

34x26

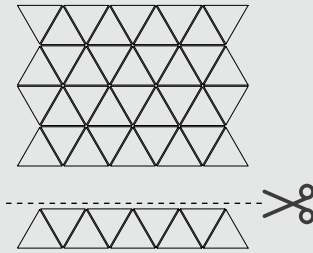



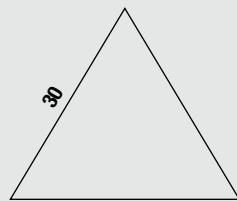

0001280
MOS. TRIANGOLI DESERT RETT.
M. 349,00 



0001111
TRIANGOLO 30 DESERT RETT.
M. 249,00  = 0,54 Mq

±7 mm

	BATTISCOPA		6,5x120
	RETT.	0001263	P. 9,50
	GRADONE PLUS		32x120x4,5x1,5
	RETT.	0001267	P. 169,00
	ANGOLARE PLUS SX		32x120x4,5x1,5
	RETT.	0001271	P. 196,00
	ANGOLARE PLUS DX		32x120x4,5x1,5
	RETT.	0001275	P. 196,00

20x120

BROWN

±7 mm

26x200 RETT.	0001079	M. 104,00
20x120 RETT.	0001078	M. 70,00

34x26

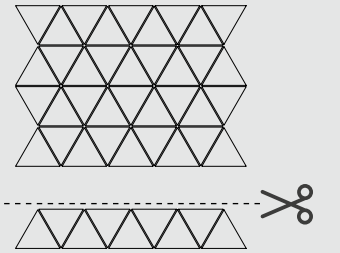



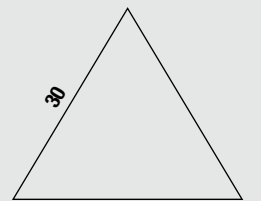



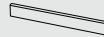

0001283
MOS. TRIANGOLI BROWN RETT.
M. 349,00 



0001114
TRIANGOLO 30 BROWN RETT.
M. 249,00  = 0,54 Mq

±7 mm

	BATTISCOPA		6,5x120
	RETT.	0001266	P. 9,50
	GRADONE PLUS		32x120x4,5x1,5
	RETT.	0001270	P. 169,00
	ANGOLARE PLUS SX		32x120x4,5x1,5
	RETT.	0001274	P. 196,00
	ANGOLARE PLUS DX		32x120x4,5x1,5
	RETT.	0001278	P. 196,00

26x200

HAVANA

±7 mm

26x200 RETT. 0002342 M. 104,00

20x120 RETT. 0002344 M. 70,00

X20 R11 ±20 mm

30x120 RETT. 0003084 M. 99,00

Per la serie completa vedi pag.: 250
For the complete collection see at page: 250

34x26

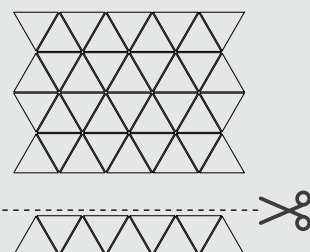

0002350
MOS. TRIANGOLI HAVANA RETT.
M. 349,00 

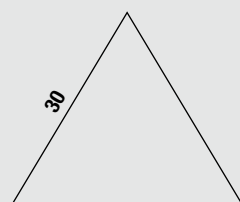

0002345
TRIANGOLO 30 HAVANA RETT.
M. 249,00  = 0,54 Mq

±7 mm

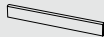
	BATTISCOPA		6,5x120
	RETT.	0002346	P. 9,50
	GRADONE PLUS		32x120x4,5x1,5
	RETT.	0002347	P. 169,00
	ANGOLARE PLUS SX		32x120x4,5x1,5
	RETT.	0002348	P. 196,00
	ANGOLARE PLUS DX		32x120x4,5x1,5
	RETT.	0002349	P. 196,00

20x120

BARK

±7 mm

26x200 RETT. 0000473 M. 104,00

20x120 RETT. 0000476 M. 70,00

X20 R11 ±20 mm

30x120 RETT. 0003085 M. 99,00

Per la serie completa vedi pag.: 250
For the complete collection see at page: 250

34x26

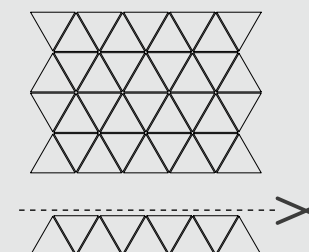



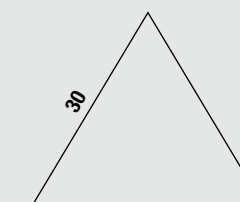



0001282
MOS. TRIANGOLI BARK RETT.
M. 349,00 

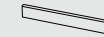

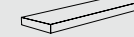
0001113
TRIANGOLO 30 BARK RETT.
M. 249,00  = 0,54 Mq

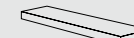
±7 mm

	BATTISCOPA		6,5x120
	RETT.	0001265	P. 9,50
	GRADONE PLUS		32x120x4,5x1,5
	RETT.	0001269	P. 169,00
	ANGOLARE PLUS SX		32x120x4,5x1,5
	RETT.	0001273	P. 196,00
	ANGOLARE PLUS DX		32x120x4,5x1,5
	RETT.	0001277	P. 196,00

20x120



BROWN TRIANGOLO 30 / HONEY TRIANGOLO 30

01.1 2 colori

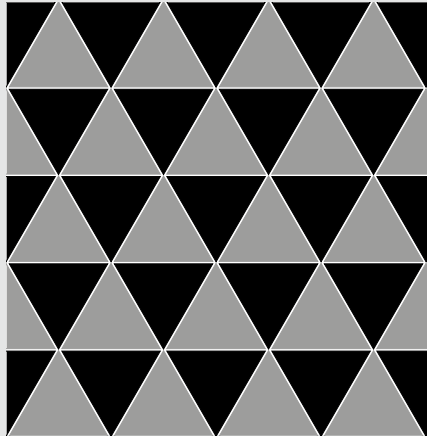

COLOR 1 50% ■
COLOR 2 50% ■

01.2 2 colori

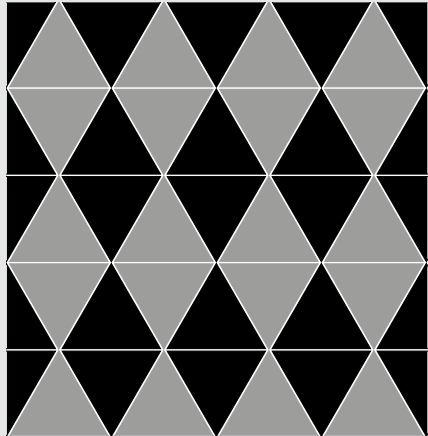

COLOR 1 50% ■
COLOR 2 50% ■

01.3 2 colori

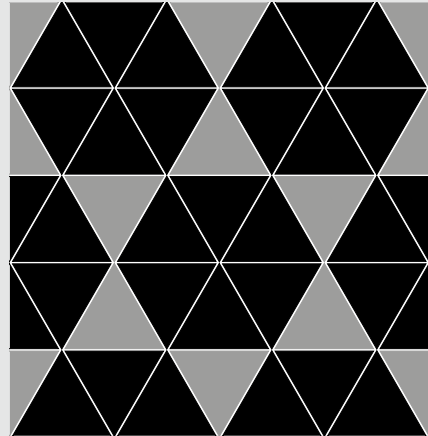

COLOR 1 75% ■
COLOR 2 25% ■

01.4 2 colori

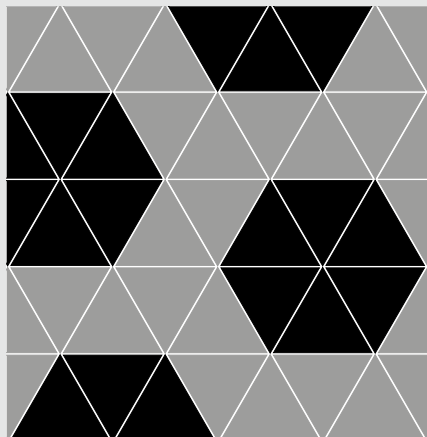

COLOR 1 57% ■
COLOR 2 43% ■

01.5 3 colori

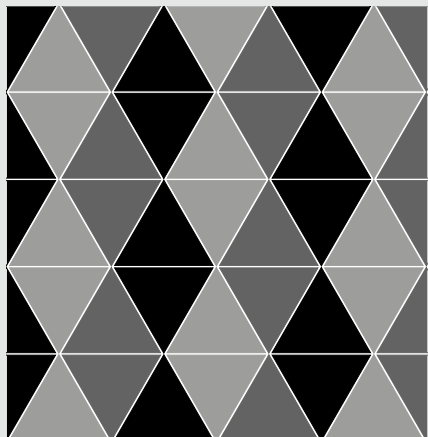

COLOR 1 33,33% ■ COLOR 3 33,33% ■
COLOR 2 33,33% ■

01.6 3 colori

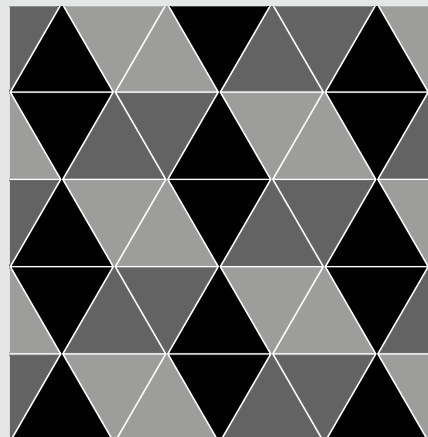

COLOR 1 33,33% ■ COLOR 3 33,33% ■
COLOR 2 33,33% ■

01.7 3 colori

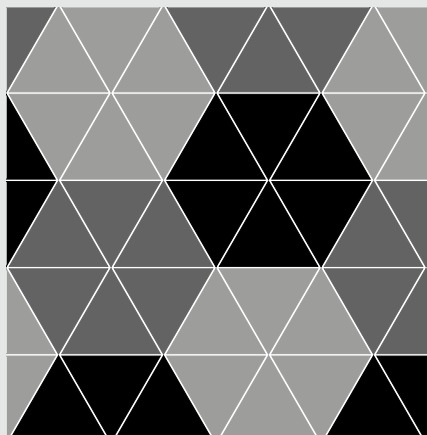

COLOR 1 33,33% ■ COLOR 3 33,33% ■
COLOR 2 33,33% ■

01.8 4 colori

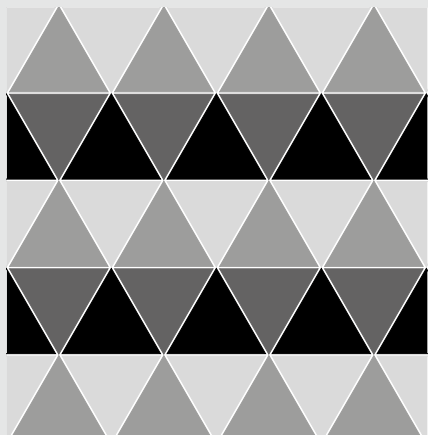

COLOR 1 25% ■ COLOR 3 25% ■
COLOR 2 25% ■ COLOR 4 25% ■

02 2 colori

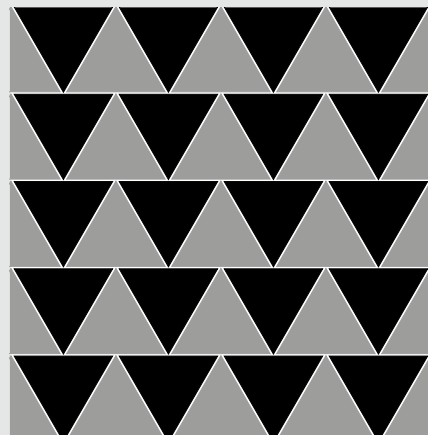

COLOR 1 50% ■
COLOR 2 50% ■

GRES PORCELLANATO - CLASSIFICAZIONE SECONDO NORME EN 14411 (ISO 13006) ALLEGATO G GRUPPO BIa
PORCELAIN TILES - CLASSIFICATION IN ACCORDANCE WITH EN 14411 (ISO 13006) ANNEX G GROUP BIa

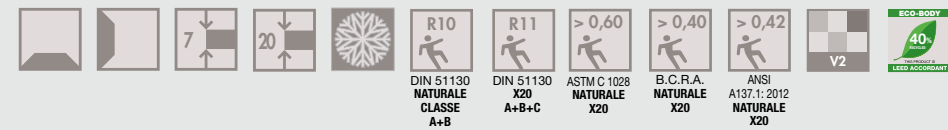

F.to nominale Nominal size	F.to reale (mm) Work size (mm)	Spessore Thickness	Tipologia imballo Type of packing	Lastre/ImballoPz/Imballo Slabs/Packing Pcs/Packing	Mq/Scatola SqM/Box	Kg/Scatola Kg/Box	Scatole/Imballo Box/Packing	Mq totali SqM total	Kg/Imballo Kg/Packing	Kg totali Kg total	Prezzo imballo Packing Price
26x200 / 10"x78" rett.	264,4x2000	7 mm	Cavalletto Rack pallet	80	5	2,60	45,50	16	41,60	50	778 -
20x120 / 8"x48" rett.	197,3x1194	7 mm	Pallet	288	8	1,92	33,60	36	69,12	20	1.230 -
30x120 / 12"x48" rett.	295x1195	20 mm	Pallet	72	2	0,72	32,65	36	25,92	20	1.190 -

I pezzi speciali, per effetto delle lavorazioni, possono presentare variazioni di tonalità. Due to working process, special trims may show variations in tonality.
L'unità minima di vendita per tutti gli articoli (fondi, decori e pezzi speciali) è la scatola completa. The minimum sales quantity for all items (plain tiles, decorations and special trims) is one full box.
I dati relativi agli imballi sono aggiornati al momento della stampa del catalogo e pertanto possono subire variazioni nel corso del tempo.
Data referring to packaging have been update at time of printing; the actual data may be slightly different.
Approfondimenti sugli imballi a pag. 282 dell'area tecnica. Details concerning packaging available at page 282 inside technical area.

COZY MULTIPLE SENSATIONS

AUTO-LEVELING™
 Facile installazione - Easy laying

MULTIPLE SENSATIONS è la materioteca di FLAVIKER, un contenitore di materie diverse sapientemente combinate insieme per dare vita ad atmosfere sorprendenti ed in linea con le principali tendenze del design contemporaneo.

MULTIPLE SENSATIONS from FLAVIKER is a collection of different materials which can be combined to create striking and original atmospheres in line with the latest trends in contemporary design.

COZY	HYPER	RIVER	HANGAR	STILL NO_W	SUPREME/ SUPREME EVO
 HAVANA	 TAUPE	 MOON	 SMOKE	 GRAY	 NOIR LAURENT
 DESERT	 TAUPE	 EARTH	 ASH	 GRAY	 BLACK DELUXE
 BROWN	 GREY	 ECRU	 SAND	 SAND	 ONYX PRESTIGE
 HONEY	 SILVER	 ECRU	 COAL	 COAL	 BLACK DELUXE
 BARK	 GREY	 LEAD	 COAL	 COAL	 EXOTIC BROWN



PLACE_2B ASPEN

AUTO-LEVELING
▶> [Click on the icon to see the video](#)

GRES PORCELLANATO A MASSA COLORATA / FULL BODY COLORED PORCELAIN TILES

SUPERFICI / SURFACES



Naturale
Natural



LUX+
Polished

FORMATI / SIZES



40x170
16"x68"



20x170
8"x68"

7 mm
9 mm



20x120
8"x48"



8,5x35
3.4"x14"

9 mm



30x120
12"x48"

20 mm

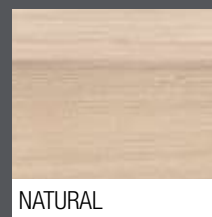

NATURAL

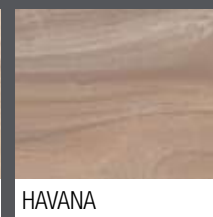

HAVANA

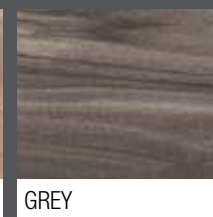

GREY



ASPEN NATURAL RETT. 40X170_GRADONE PLUS ASPEN NATURAL 32X120X4,5X2

PLACE_2B ASPEN

GRES PORCELLANATO A MASSA COLORATA
FULL BODY COLORED PORCELAIN TILES

WOOD

GREY

NATURAL



20x170



20x170

R: Rettificato | Rectified
L: Lux*

R: Rettificato | Rectified
L: Lux*

40x170 **20x170**

20x120 **5x120 LISTELLO LUX***

AN 4722 R M. 93,00 AN 2722 R M. 93,00 AN 2122 R M. 70,00 AN DL 222 P. 10,00

AN 4722 L M. 102,00 AN 2722 L M. 102,00

⊗ 9mm
⊗ 7mm

40x170 **20x170**

20x120 **5x120 LISTELLO LUX***

AN 4713 R M. 93,00 AN 2713 R M. 93,00 AN 2113 R M. 70,00 AN DL 132 P. 10,00

AN 4713 L M. 102,00 AN 2713 L M. 102,00

⊗ 9mm
⊗ 7mm

Battiscopa Rettificato 6,5x120 AN BN 222 P. 9,50

Gradone Plus 32x120x4,5x2 AN RT 222 P. 169,00
Gradone Plus Lux* 32x120x4,5x1,5 AN RL 222 P. 179,00

Angolare Plus sx 32x120x4,5x2 AN RA 22S P. 196,00
Ang. Plus Lux* sx 32x120x4,5x1,5 AN RL 22S P. 206,00

Angolare Plus dx 32x120x4,5x2 AN RA 22D P. 196,00
Ang. Plus Lux* dx 32x120x4,5x1,5 AN RL 22D P. 206,00

Battiscopa Rettificato 6,5x120 AN BN 132 P. 9,50

Gradone Plus 32x120x4,5x2 AN RT 132 P. 169,00
Gradone Plus Lux* 32x120x4,5x1,5 AN RL 132 P. 179,00

Angolare Plus sx 32x120x4,5x2 AN RA 13S P. 196,00
Ang. Plus Lux* sx 32x120x4,5x1,5 AN RL 13S P. 206,00

Angolare Plus dx 32x120x4,5x2 AN RA 13D P. 196,00
Ang. Plus Lux* dx 32x120x4,5x1,5 AN RL 13D P. 206,00

PLACE_2B ASPEN

HAVANA

GRES PORCELLANATO A MASSA COLORATA
FULL BODY COLORED PORCELAIN TILES

GRES PORCELLANATO
PORCELAIN TILES

WOOD



RESIZE



8,5x35
AN 83 530 M. 53,50
ASPEN HAVANA / NATURAL



ASPEN HAVANA/NATURAL 8,5X35

20x170

R: Rettificato | Rectified
L: Lux*

*Per la serie completa vedi pag.218 | For the complete collection see page 218

40x170
AN 4730 R M. 93,00
AN 4730 L M. 102,00

20x170
AN 2730 R M. 93,00
AN 2730 L M. 102,00

20x120
AN 2130 R M. 70,00

20mm 30x120 X20
R11

5x120 LISTELLO LUX*
4

AN DL 302 P. 10,00

*AN 3130 M M. 99,00

± 9mm
± 7mm
± 20mm

Battiscopa Rettificato 6,5x120
AN BN 302 P. 9,50

Gradone Plus 32x120x4,5x2
AN RT 302 P. 169,00
Gradone Plus Lux* 32x120x4,5x1,5
AN RL 302 P. 179,00

Angolare Plus sx 32x120x4,5x2
AN RA 30S P. 196,00
Ang. Plus Lux* sx 32x120x4,5x1,5
AN RL 30S P. 206,00

Angolare Plus dx 32x120x4,5x2
AN RA 30D P. 196,00
Ang. Plus Lux* dx 32x120x4,5x1,5
AN RL 30D P. 206,00

GRES PORCELLANATO A MASSA COLORATA - CLASSIFICAZIONE SECONDO NORME EN 14411 (ISO 13006) ALLEGATO G GRUPPO BIa
FULL BODY COLORED PORCELAIN TILES - CLASSIFICATION IN ACCORDANCE WITH EN 14411 (ISO 13006) ANNEX G GROUP BIa

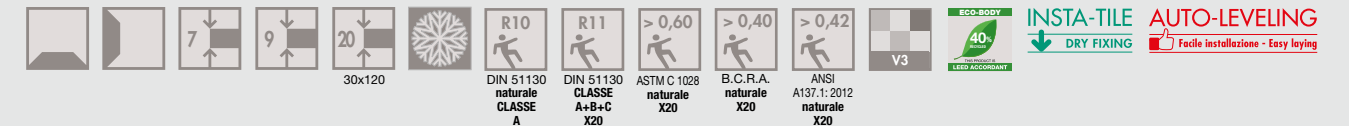

F.to nominale Nominal size	F.to reale (mm) Work size (mm)	Spessore Thickness	Tipologia imballo Type of packing	Lastre/ImballoPz/Imballo Slabs/Packing Pcs/Packing	Mq/Scatola SqM/Box	Kg/Scatola Kg/Box	Scatole/Imballo Box/Packing	Mq totali SqM total	Kg/Imballo Kg/Packing	Kg totali Kg total	Prezzo imballo Packing Price	
40x170 / 16"x68" rett.	400x1700	9	Pallet	64	2	1,36	27,00	32	43,52	20	884	-
40x170 / 16"x68" lux	400x1700	7	Pallet	96	3	2,04	35,00	32	65,28	20	1.164	-
20x170 / 8"x68" rett.	199x1700	9	Pallet	144	4	1,36	27,00	36	48,96	20	992	-
20x170 / 8"x68" lux	199x1700	7	Pallet	180	5	1,70	29,00	36	61,20	20	1.088	-
20x120 / 8"x48" rett.	199x1194	9	Pallet	216	6	1,44	27,20	36	51,84	20	999	-
30x120 / 12"x48" rett.	295x1200	20	Pallet	64	2	0,72	33,62	32	23,04	20	1.096	-
8,5x35 / 3.4"x14" nat.	-	9	Pallet	1680	20	0,602	12,50	84	50,57	20	1.065	-

I pezzi speciali, per effetto delle lavorazioni, possono presentare variazioni di tonalità. Due to working process, special trims may show variations in tonality. L'unità minima di vendita per tutti gli articoli (fondi, decori e pezzi speciali) è la scatola completa. The minimum sales quantity for all items (plain tiles, decorations and special trims) is one full box. I dati relativi agli imballi sono aggiornati al momento della stampa del catalogo e pertanto possono subire variazioni nel corso del tempo. Data referring to packaging have been update at time of printing; the actual data may be slightly different. Approfondimenti sugli imballi a pag. 282 dell'area tecnica. Details concerning packaging available at page 282 inside technical area.

PLACE_2B DUBLIN

AUTO-LEVELING
Il look realistico, tra l'altro

GRES PORCELLANATO A MASSA COLORATA / FULL BODY COLORED PORCELAIN TILES

SUPERFICI / SURFACES



Naturale
Natural

FORMATI / SIZES

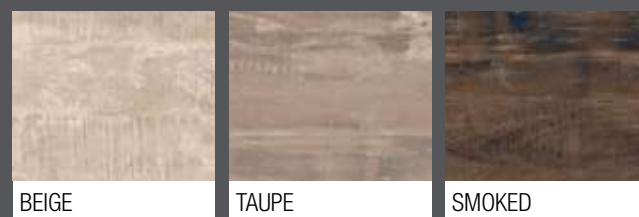
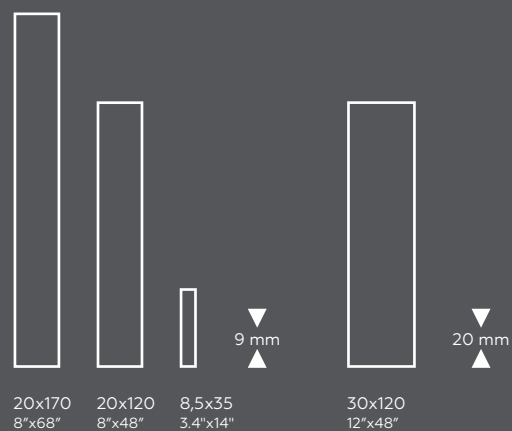

DUBLIN BEIGE RETT. 20X170_20X120

PLACE_2B DUBLIN

GRES PORCELLANATO A MASSA COLORATA
FULL BODY COLORED PORCELAIN TILES

WOOD

TAUPE

BEIGE



20x170



20x170

R: Rettificato | Rectified

*Per la serie completa vedi pag. 252 | For the complete collection see page 252

R: Rettificato | Rectified

20x170



DB 2723 R M. 93,00

20x120

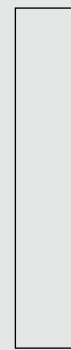

DB 2123 R M. 70,00

R11
20mm
30x120
X20

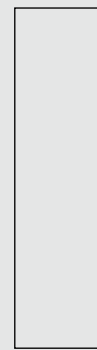

*DB 3123 M
M. 99,00

20x170



DB 2730 R M. 93,00

20x120

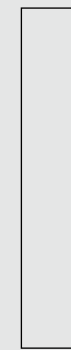

DB 2130 R M. 70,00



Battiscopa Rettificato 6,5x120
DB BN 232 P. 9,50

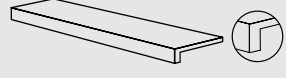

Gradone Plus 32x120x4,5x2
DB RT 232 P. 169,00

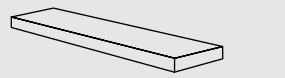

Angolare Plus sx 32x120x4,5x2
DB RA 23S P. 196,00
Angolare Plus dx 32x120x4,5x2
DB RA 23D P. 196,00



Battiscopa Rettificato 6,5x120
DB BN 302 P. 9,50

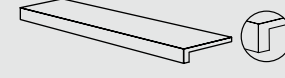

Gradone Plus 32x120x4,5x2
DB RT 302 P. 169,00

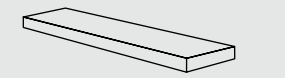

Angolare Plus sx 32x120x4,5x2
DB RA 30S P. 196,00
Angolare Plus dx 32x120x4,5x2
DB RA 30D P. 196,00

PLACE_2B DUBLIN

SMOKED

GRES PORCELLANATO A MASSA COLORATA
FULL BODY COLORED PORCELAIN TILES

GRES PORCELLANATO
PORCELAIN TILES

WOOD



20x170

R: Rettificato | Rectified

20x170



DB 2790 R M. 93,00

20x120

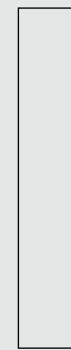

DB 2190 R M. 70,00



Battiscopa Rettificato 6,5x120
DB BN 902 P. 9,50

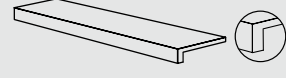

Gradone Plus 32x120x4,5x2
DB RT 902 P. 169,00

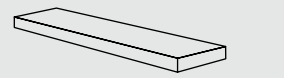

Angolare Plus sx 32x120x4,5x2
DB RA 90S P. 196,00
Angolare Plus dx 32x120x4,5x2
DB RA 90D P. 196,00

RESIZE

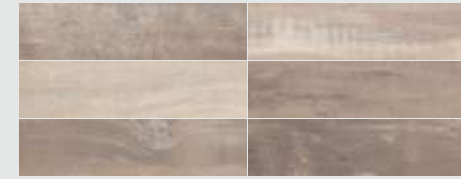

8,5x35
AN 83 513 M. 53,50
DUBLIN TAUPE / BEIGE

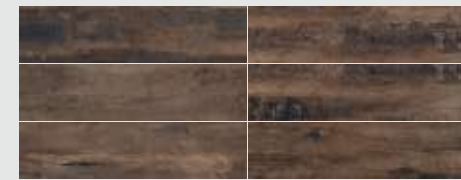

8,5x35
AN 83 522 M. 53,50
DUBLIN SMOKED



DUBLIN TAUPE/BEIGE 8,5X35

GRES PORCELLANATO A MASSA COLORATA - CLASSIFICAZIONE SECONDO NORME EN 14411 (ISO 13006) ALLEGATO G GRUPPO BIa
FULL BODY COLORED PORCELAIN STONEWARE - CLASSIFICATION IN ACCORDANCE WITH EN 14411 (ISO 13006) ANNEX G GROUP BIa

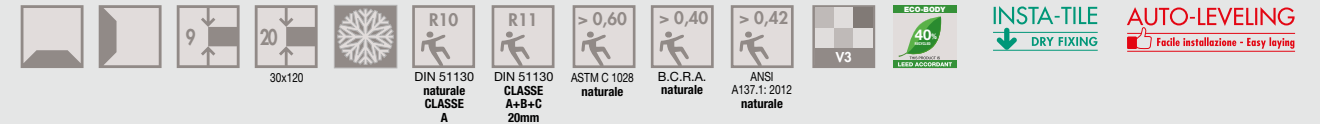

F.to nominale Nominal size	F.to reale (mm) Work size (mm)	Spessore Thickness	Tipologia imballo Type of packing	Lastre/Imballo Slabs/Packing	Pz/Imballo Pcs/Packing	Mq/Scatola SqM/Box	Kg/Scatola Kg/Box	Scatole/Imballo Box/Packing	Mq totali SqM total	Kg/Imballo Kg/Packing	Kg totali Kg total	Prezzo imballo Packing Price
20x170 / 8"x68" rett.	199x1700	9	Pallet	144	4	1,36	27,00	36	48,96	20	992	-
20x120 / 8"x48" rett.	199x1194	9	Pallet	216	6	1,44	27,20	36	51,84	20	999	-
30x120 / 12"x48" rett.	295x1200	20	Pallet	64	2	0,72	33,62	32	23,04	20	1.096	-
8,5x35 / 3.4"x14" nat.	-	9	Pallet	1680	20	0,602	12,50	84	50,57	20	1.065	-

I pezzi speciali, per effetto delle lavorazioni, possono presentare variazioni di tonalità. Due to working process, special trims may show variations in tonality. L'unità minima di vendita per tutti gli articoli (fondi, decori e pezzi speciali) è la scatola completa. The minimum sales quantity for all items (plain tiles, decorations and special trims) is one full box. I dati relativi agli imballi sono aggiornati al momento della stampa del catalogo e pertanto possono subire variazioni nel corso del tempo. Data referring to packaging have been update at time of printing; the actual data may be slightly different. Approfondimenti sugli imballi a pag. 282 dell'area tecnica. Details concerning packaging available at page 282 inside technical area.

DAKOTA

AUTO-LEVELING™
▶ [Info](#) ▶ [Downloads](#) ▶ [Buy Now](#)

GRES PORCELLANATO A MASSA COLORATA / FULL BODY COLORED PORCELAIN TILES

SUPERFICI / SURFACES



Naturale
Natural



Reserve
Structured

FORMATI / SIZES



40x170
16"x68"



20x170
8"x68"



30x120
12"x48"



20x120
8"x48"



20x80
8"x32"

9 mm



30x120
12"x48"

20 mm



NATURALE



AVANA



GRIGIO



TORTORA



DAKOTA NATURALE 20X170, 20X120



20x80

20x80

R: Rettificato | Rectified
S: Reserve Rettificato | Rectified

*Per la serie completa vedi pag. 254 | For the complete collection see page 254

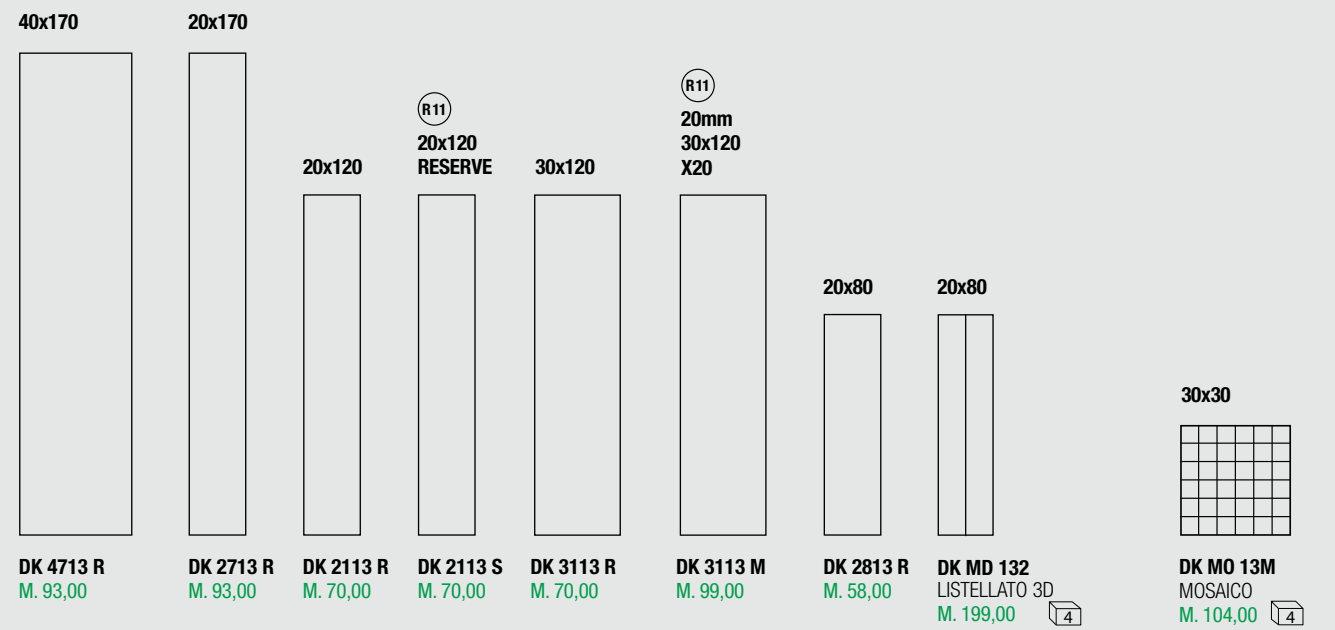

Battiscopa Rettificato
DK BN 132 6,5x120 P. 9,50
DK BN 139 6,5x80 P. 8,00

Elemento Elle Rettificato Reserve 15x60x4
DK EN 136 P. 46,50

Gradone Plus 32x120x4,5x2
DK RT 132 A P. 169,00

Angolare Plus sx 32x120x4,5x2
DK RA 13S
Angolare Plus dx 32x120x4,5x2
DK RA 13D P. 196,00



R: Rettificato | Rectified
S: Reserve Rettificato | Rectified

*Per la serie completa vedi pag. 254 | For the complete collection see page 254

R: Rettificato | Rectified
S: Reserve Rettificato | Rectified

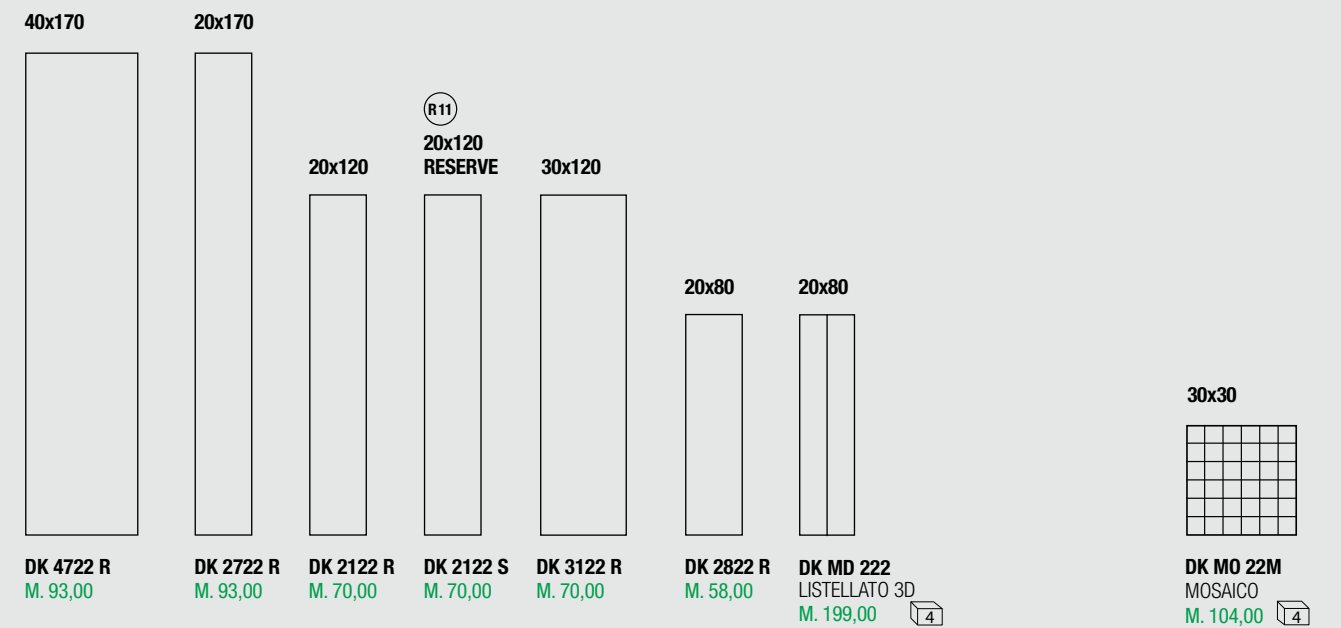
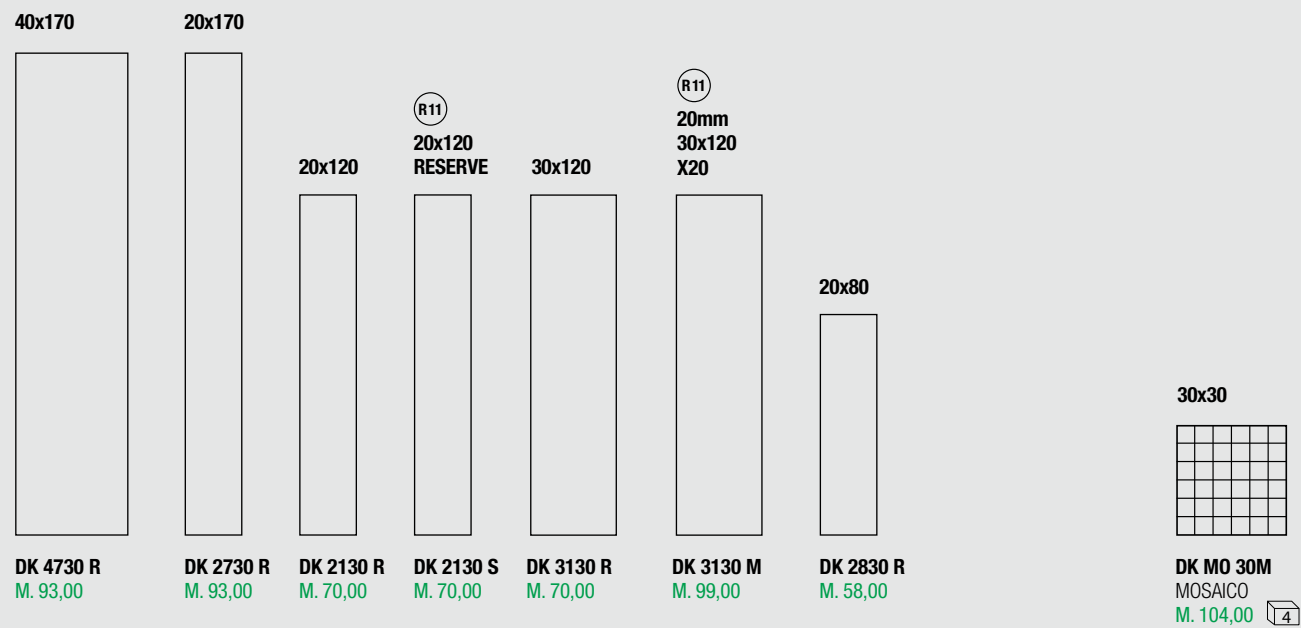

Battiscopa Rettificato
DK BN 302 6,5x120 P. 9,50
DK BN 309 6,5x80 P. 8,00

Elemento Elle Rettificato Reserve 15x60x4
DK EN 306 P. 46,50

Gradone Plus 32x120x4,5x2
DK RT 302 A P. 169,00

Angolare Plus sx 32x120x4,5x2
DK RA 30S
Angolare Plus dx 32x120x4,5x2
DK RA 30D P. 196,00

Battiscopa Rettificato
DK BN 222 6,5x120 P. 9,50
DK BN 229 6,5x80 P. 8,00

Elemento Elle Rettificato Reserve 15x60x4
DK EN 226 P. 46,50

Gradone Plus 32x120x4,5x2
DK RT 222 A P. 169,00

Angolare Plus sx 32x120x4,5x2
DK RA 22S
Angolare Plus dx 32x120x4,5x2
DK RA 22D P. 196,00

TORTORA



20x80

20x80

R: Rettificato | Rectified
S: Reserve Rettificato | Rectified

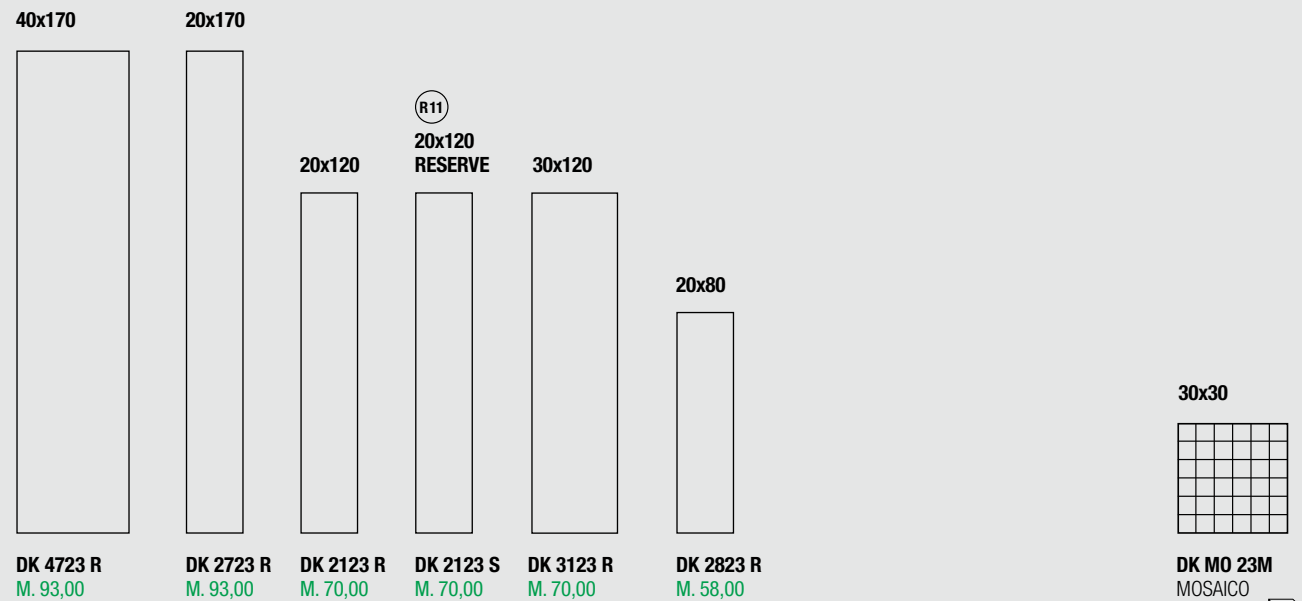

DECORI / DECORS



SCHEMI DI POSA / INSTALLATION PATTERNS

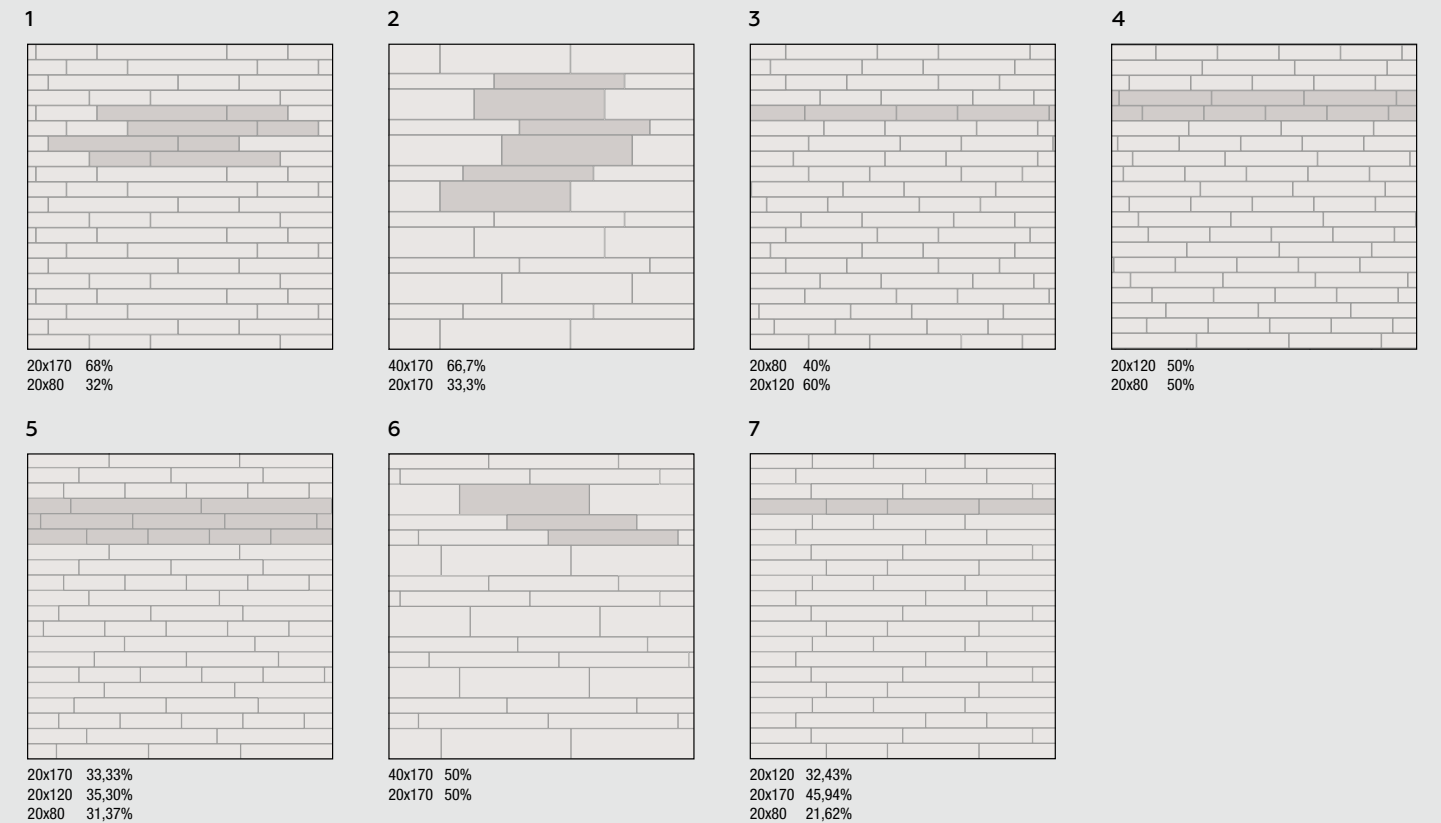

GRES PORCELLANATO A MASSA COLORATA - CLASSIFICAZIONE SECONDO NORME EN 14411 (ISO 13006) ALLEGATO G GRUPPO B1a
FULL BODY COLORED PORCELAIN TILES - CLASSIFICATION IN ACCORDANCE WITH EN 14411 (ISO 13006) ANNEX G GROUP B1a

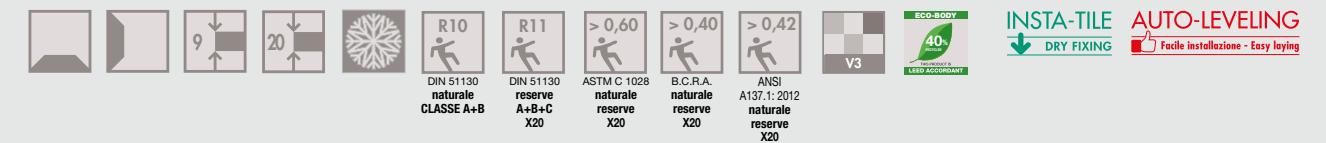

F.to nominale	F.to reale (mm)	Spessore	Tipologia imballo	Lastre/Imballo	Pz/Imballo	Mq/Scatola	Kg/Scatola	Scatole/Imballo	Mq totali	Kg/Imballo	Kg totali	Prezzo imballo
Nominal size	Work size (mm)	Thickness	Type of packing	Slabs/Packing	Pcs/Packing	Sqm/Box	Kg/Box	Box/Packing	Sqm total	Kg/Packing	Kg total	Packing Price
40x170 / 16"x68" rett.	400x1700	9	Pallet	64	2	1,36	27,00	32	43,52	20	884	-
20x170 / 8"x68" rett.	199x1700	9	Pallet	144	4	1,36	27,00	36	48,96	20	992	-
20x120 / 8"x48" rett.	199x1194	9	Pallet	216	6	1,44	27,20	36	51,84	20	999	-
20x80 / 8"x32" rett.	199x800	9	Pallet	336	8	1,28	25,00	42	53,76	20	1.070	-
30x120 / 12"x48" rett.	297x1194	9	Pallet	144	4	1,44	28,00	36	51,84	20	1.028	-
30x120 / 12"x48" rett.	295x1200	20	Pallet	64	2	0,72	33,62	32	23,04	20	1.096	-

I pezzi speciali, per effetto delle lavorazioni, possono presentare variazioni di tonalità. Due to working process, special trims may show variations in tonality. L'unità minima di vendita per tutti gli articoli (fondi, decori e pezzi speciali) è la scatola completa. The minimum sales quantity for all items (plain tiles, decorations and special trims) is one full box. I dati relativi agli imballi sono aggiornati al momento della stampa del catalogo e pertanto possono subire variazioni nel corso del tempo. Data referring to packaging have been update at time of printing; the actual data may be slightly different. Approfondimenti sugli imballi a pag. 282 dell'area tecnica. Details concerning packaging available at page 282 inside technical area.

ZEN

AUTO-LEVELING™
▶ [Info e download](#) [in pdf](#)

GRES PORCELLANATO A MASSA COLORATA / FULL BODY COLORED PORCELAIN TILES

SUPERFICI / SURFACES



Naturale
Natural

FORMATI / SIZES



20x120
8"x48"

20x170
8"x68"

9 mm



BONE



HONEY



CAMEL



OAK



ZEN CAMEL 20x120

ZEN

GRES PORCELLANATO A MASSA COLORATA
FULL BODY COLORED PORCELAIN TILES

WOOD

BONE

CAMEL



20x120



20x120

20x120

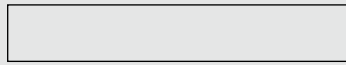

0004938 RETT
M. 55,00



Battiscopa Rettificato
0004946 6,5x120 P. 8,50



20x170

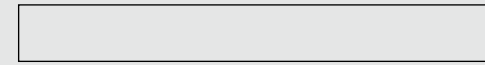

0005051 RETT
M. 73,00



Battiscopa Rettificato
0004948 6,5x120 P. 8,50



20x120

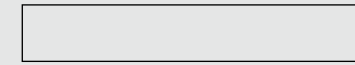

0004940 RETT
M. 55,00

HONEY

OAK



20x120



20x120

20x170



0005050 RETT
M. 73,00



Battiscopa Rettificato
0004947 6,5x120 P. 8,50



20x120

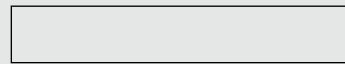

0004939 RETT
M. 55,00

20x120

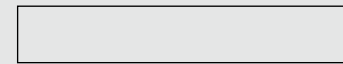

0004941 RETT
M. 55,00



Battiscopa Rettificato
0004949 6,5x120 P. 8,50



GRES PORCELLANATO A MASSA COLORATA - CLASSIFICAZIONE SECONDO NORME EN 14411 (ISO 13006) ALLEGATO G GRUPPO BIa
FULL BODY COLORED PORCELAIN STONEWARE - CLASSIFICATION IN ACCORDANCE WITH EN 14411 (ISO 13006) ANNEX G GROUP BIa



F.to nominale Nominal size	F.to reale (mm) Work size (mm)	Spessore Thickness	Tipologia imballo Type of packing	Lastre/Imballo Slabs/Packing	Pz/Imballo Pcs/Packing	Mq/Scatola SqM/Box	Kg/Scatola Kg/Box	Scatole/Imballo Box/Packing	Mq totale SqM total	Kg/Imballo Kg/Packing	Kg totale Kg total	Prezzo imballo Packing Price
20x120 / 8"x48" rett.	199x1194	9	Pallet	216	6	1,44	27,20	36	51,84	20	999	-
20x170 / 8"x68" rett.	199x1700	9	Pallet	144	4	1,36	27,00	36	48,96	20	992	-

I pezzi speciali, per effetto delle lavorazioni, possono presentare variazioni di tonalità. Due to working process, special trims may show variations in tonality. L'unità minima di vendita per tutti gli articoli (fondi, decori e pezzi speciali) è la scatola completa. The minimum sales quantity for all items (plain tiles, decorations and special trims) is one full box. I dati relativi agli imballi sono aggiornati al momento della stampa del catalogo e pertanto possono subire variazioni nel corso del tempo. Data referring to packaging have been update at time of printing; the actual data may be slightly different. Approfondimenti sugli imballi a pag. 282 dell'area tecnica. Details concerning packaging available at page 282 inside technical area.



X20 PORCELAIN TILES 20 MM

**GRES PORCELLANATO
20 MM**

- 228 REBEL
- 230 HYPER
- 232 RIVER
- 234 HANGAR
- 236 BACKSTAGE
- 238 NORDIK STONE
- 240 STILL NO_W
- 242 NO_W
- 244 FORWARD
- 246 SHADOW
- 248 NORDIK WOOD
- 250 COZY
- 252 PLACE_2B
- 254 DAKOTA

X20 20MM

REBEL

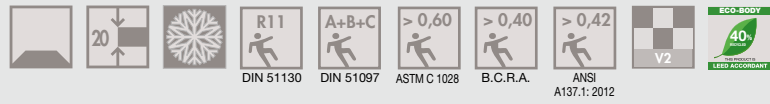

90x90
0004251 REBEL BRONZE 20 mm RETT. 
M. 99,00



90x90
0004252 REBEL LEAD 20 mm RETT. 
M. 99,00



90x90
0004253 REBEL SILVER 20 mm RETT. 
M. 99,00

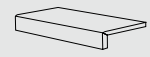

15X90X5
0004255 ELEMENTO L
BRONZE 20 mm RETT.  P. 119,00

0004256 ELEMENTO L
LEAD 20 mm RETT. P. 119,00

0004257 ELEMENTO L
SILVER 20 mm RETT. P. 119,00



18X90
0004258 GRIGLIA
BRONZE 20 mm RETT.  P. 199,00

0004259 GRIGLIA
LEAD 20 mm RETT. P. 199,00

0004260 GRIGLIA
SILVER 20 mm RETT. P. 199,00

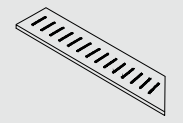

18X90
0004261 ANG. GRIGLIA SX
BRONZE 20 mm RETT.  P. 259,00

0004262 ANG. GRIGLIA SX
LEAD 20 mm RETT. P. 259,00

0004263 ANG. GRIGLIA SX
SILVER 20 mm RETT. P. 259,00

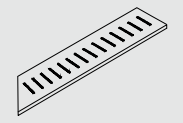

18X90
0004264 ANG. GRIGLIA DX
BRONZE 20 mm RETT.  P. 259,00

0004265 ANG. GRIGLIA DX
LEAD 20 mm RETT. P. 259,00

0004266 ANG. GRIGLIA DX
SILVER 20 mm RETT. P. 259,00

F.to nominale	F.to reale (mm)	Spessore	Tipologia imballo	Lastre/Imballo	Pz/Imballo	Mq/Scatola	Kg/Scatola	Scatole/Imballo	Mq totali	Kg/Imballo	Kg totali	Prezzo imballo
Nominal size	Work size (mm)	Thickness	Type of packing	Slabs/Packing	Pcs/Packing	Sqm/Box	Kg/Box	Box/Packing	Sqm total	Kg/Packing	Kg total	Packing Price
90x90 / 36"x36" rett.	896x896	20	Pallet	30	1	0,81	36,60	30	24,30	20	1.118	-

I pezzi speciali, per effetto delle lavorazioni, possono presentare variazioni di tonalità. Due to working process, special trims may show variations in tonality.
L'unità minima di vendita per tutti gli articoli (fondi, decori e pezzi speciali) è la scatola completa. The minimum sales quantity for all items (plain tiles, decorations and special trims) is one full box.
I dati relativi agli imballi sono aggiornati al momento della stampa del catalogo e pertanto possono subire variazioni nel corso del tempo.
Data referring to packaging have been update at time of printing; the actual data may be slightly different.

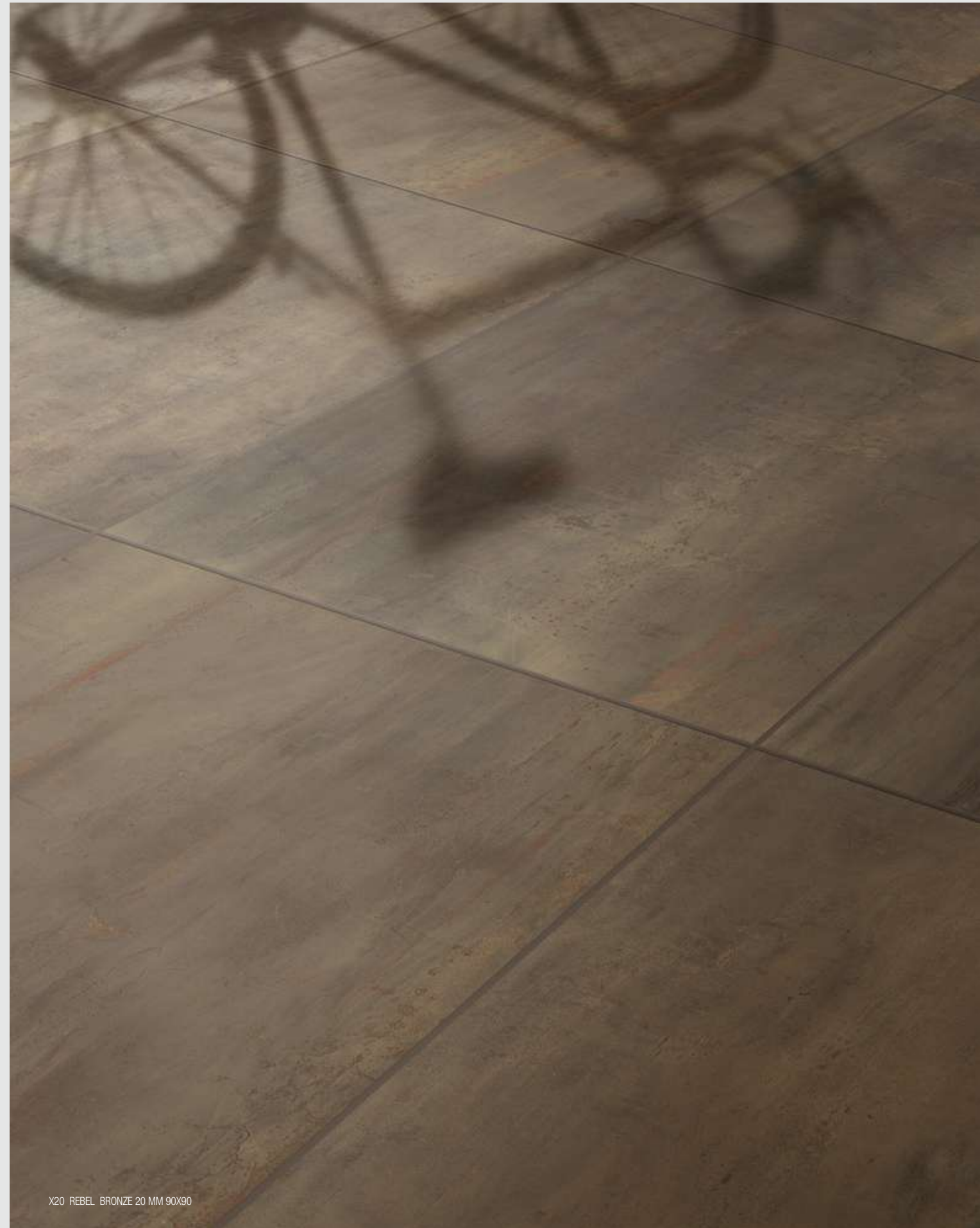

X20 REBEL BRONZE 20 MM 90X90

X20 20MM

HYPER

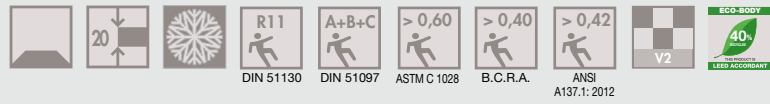

60x120
0002770 HYPER SILVER 20 mm RETT. 
 M. 99,00



60x120
0002771 HYPER GREY 20 mm RETT. 
 M. 99,00



60x120
0002772 HYPER TAUPE 20 mm RETT. 
 M. 99,00



15X60X5 
0002773 ELEMENTO L
 SILVER 20 mm RETT P. 89,00
0002774 ELEMENTO L
 GREY 20 mm RETT P. 89,00
0002775 ELEMENTO L
 TAUPE 20 mm RETT P. 89,00

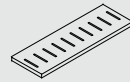

15X60 
0002776 GRIGLIA
 SILVER 20 mm RETT P. 169,00
0002777 GRIGLIA
 GREY 20 mm RETT P. 169,00
0002778 GRIGLIA
 TAUPE 20 mm RETT P. 169,00

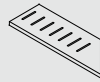

15X60 
0002779 ANG. GRIGLIA SX
 SILVER 20 mm RETT P. 229,00
0002780 ANG. GRIGLIA SX
 GREY 20 mm RETT P. 229,00
0002781 ANG. GRIGLIA SX
 TAUPE 20 mm RETT P. 229,00

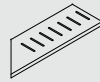

15X60 
0002782 ANG. GRIGLIA DX
 SILVER 20 mm RETT P. 229,00
0002783 ANG. GRIGLIA DX
 GREY 20 mm RETT P. 229,00
0002784 ANG. GRIGLIA DX
 TAUPE 20 mm RETT P. 229,00

F.to nominale Nominal size	F.to reale (mm) Work size (mm)	Spessore Thickness	Tipologia imballo Type of packing	Lastre/Imballo Slabs/Packing	Pz/Imballo Pcs/Packing	Mq/Scatola SqM/Box	Kg/Scatola Kg/Box	Scatole/Imballo Box/Packing	Mq totali SqM total	Kg/Imballo Kg/Packing	Kg totali Kg total	Prezzo imballo Packing Price
60x120 / 24"x48" rett.	596x1195	20	Pallet	30	1	0,72	32,65	30	21,60	20	1.000	-

I pezzi speciali, per effetto delle lavorazioni, possono presentare variazioni di tonalità. Due to working process, special trims may show variations in tonality.
 L'unità minima di vendita per tutti gli articoli (fondi, decori e pezzi speciali) è la scatola completa. The minimum sales quantity for all items (plain tiles, decorations and special trims) is one full box.
 I dati relativi agli imballi sono aggiornati al momento della stampa del catalogo e pertanto possono subire variazioni nel corso del tempo.
 Data referring to packaging have been update at time of printing; the actual data may be slightly different.



HYPER GREY RETT. 120X270 - 60X120 20MM

X20 20MM

RIVER

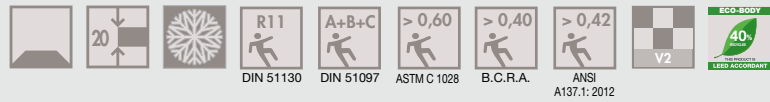

60x120
0001790 RIVER LEAD 20 mm RETT.
 M. 99,00



60x120
0001789 RIVER ECRU 20 mm RETT.
 M. 99,00



15X60X5
0002278 ELEMENTO L
 LEAD 20 mm RETT P. 89,00
0002277 ELEMENTO L
 ECRU 20 mm RETT P. 89,00

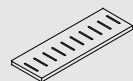

15X60
0002280 GRIGLIA
 LEAD 20 mm RETT P. 169,00
0002279 GRIGLIA
 ECRU 20 mm RETT P. 169,00

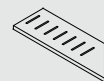

15X60
0002282 ANG. GRIGLIA SX
 LEAD 20 mm RETT P. 229,00
0002281 ANG. GRIGLIA SX
 ECRU 20 mm RETT P. 229,00

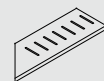

15X60
0002284 ANG. GRIGLIA DX
 LEAD 20 mm RETT P. 229,00
0002283 ANG. GRIGLIA DX
 ECRU 20 mm RETT P. 229,00



F.to nominale Nominal size	F.to reale (mm) Work size (mm)	Spessore Thickness	Tipologia imballo Type of packing	Lastre/Imballo Slabs/Packing	Pz/Imballo Pcs/Packing	Mq/Scatola Sqm/Box	Kg/Scatola Kg/Box	Scatole/Imballo Box/Packing	Mq totali Sqm total	Kg/Imballo Kg/Packing	Kg totali Kg total	Prezzo imballo Packing Price
60x120 / 24"x48" rett.	596x1195	20	Pallet	30	1	0,72	32,65	30	21,60	20	1.000	-

I pezzi speciali, per effetto delle lavorazioni, possono presentare variazioni di tonalità. Due to working process, special trims may show variations in tonality.
 L'unità minima di vendita per tutti gli articoli (fondi, decori e pezzi speciali) è la scatola completa. The minimum sales quantity for all items (plain tiles, decorations and special trims) is one full box.
 I dati relativi agli imballi sono aggiornati al momento della stampa del catalogo e pertanto possono subire variazioni nel corso del tempo.
 Data referring to packaging have been update at time of printing; the actual data may be slightly different.

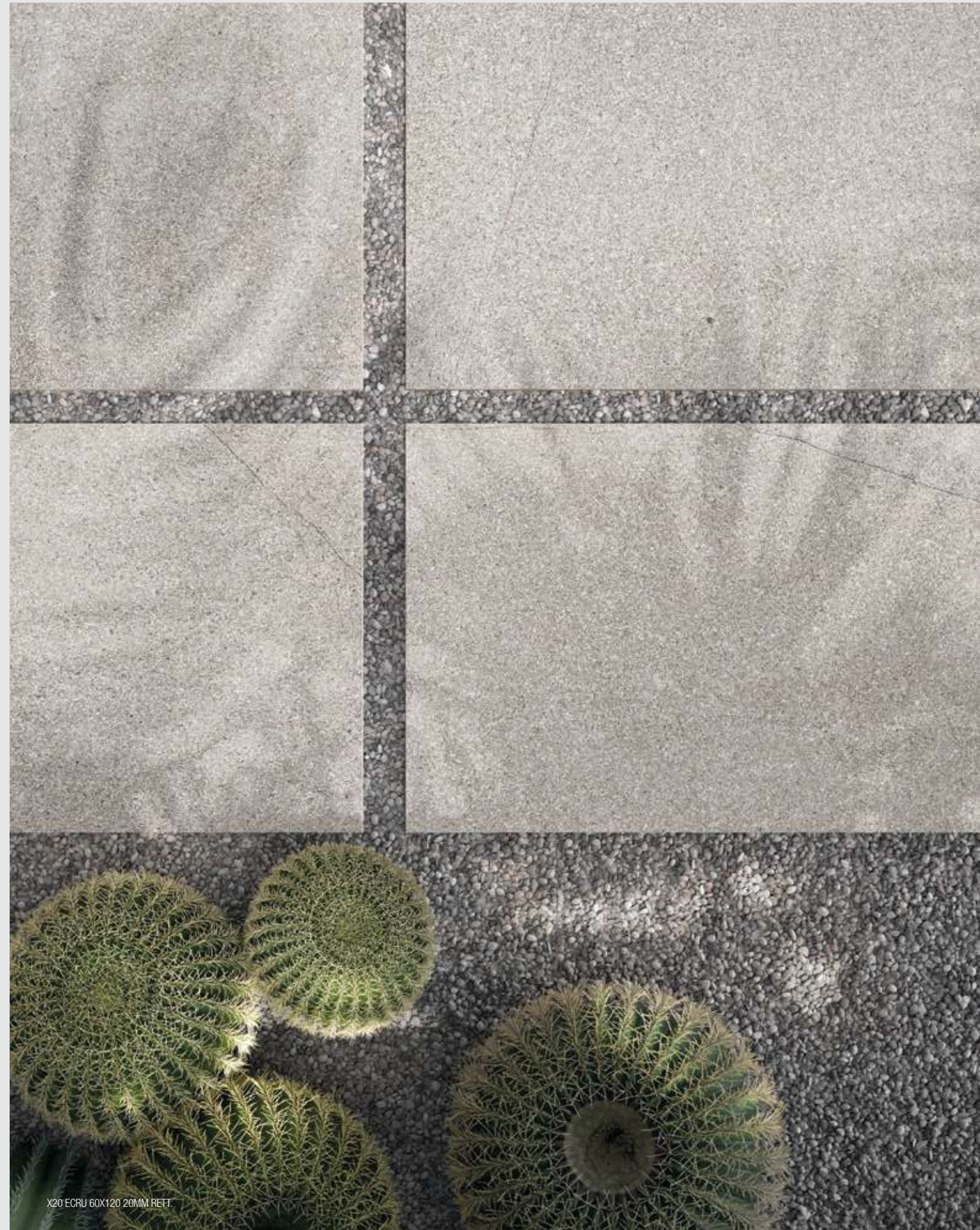

X20 ECRU 60X120 20MM RETT.

X20 20MM

HANGAR

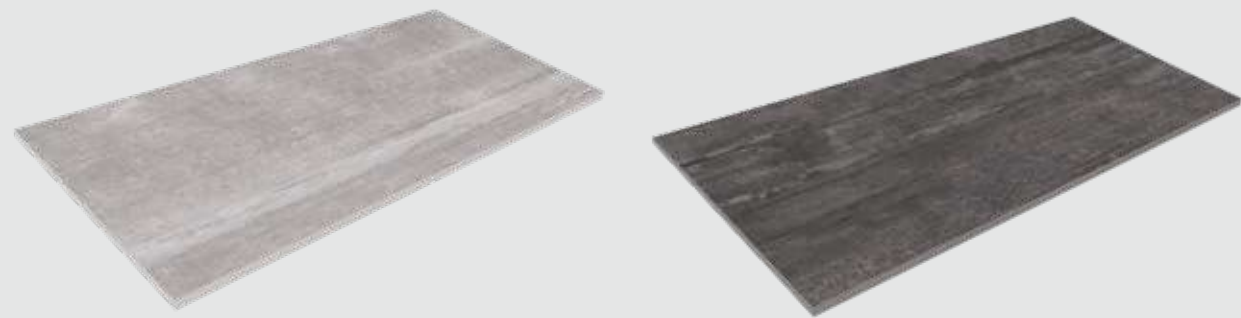
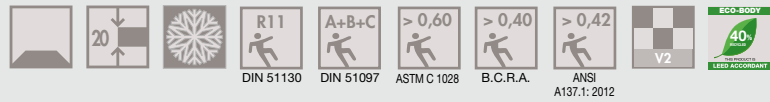

60x120
0000951 HANGAR SMOKE 20 mm RETT. 
 M. 99,00

60x120
0000952 HANGAR COAL 20 mm RETT. 
 M. 99,00



15X60X5
0001018 ELEMENTO L
 SMOKE 20 mm RETT **P. 89,00**
0001019 ELEMENTO L
 COAL 20 mm RETT **P. 89,00**

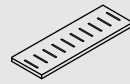

15X60
0001020 GRIGLIA
 SMOKE 20 mm RETT **P. 169,00**
0001021 GRIGLIA
 COAL 20 mm RETT **P. 169,00**

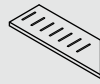

15X60
0001022 ANG. GRIGLIA SX
 SMOKE 20 mm RETT **P. 229,00**
0001023 ANG. GRIGLIA SX
 COAL 20 mm RETT **P. 229,00**

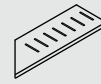

15X60
0001024 ANG. GRIGLIA DX
 SMOKE 20 mm RETT **P. 229,00**
0001025 ANG. GRIGLIA DX
 COAL 20 mm RETT **P. 229,00**

F.to nominale	F.to reale (mm)	Spessore	Tipologia imballo	Lastre/Imballo	Pz/Imballo	Mq/Scatola	Kg/Scatola	Scatole/Imballo	Mq totali	Kg/Imballo	Kg totali	Prezzo imballo
Nominal size	Work size (mm)	Thickness	Type of packing	Slabs/Packing	Pcs/Packing	Sqm/Box	Kg/Box	Box/Packing	Sqm total	Kg/Packing	Kg total	Packing Price
60x120 / 24"x48" rett.	600x1200	20	Pallet	27	1	0,72	34,36	27	19,44	20	943	-

I pezzi speciali, per effetto delle lavorazioni, possono presentare variazioni di tonalità. Due to working process, special trims may show variations in tonality.
 L'unità minima di vendita per tutti gli articoli (fondi, decori e pezzi speciali) è la scatola completa. The minimum sales quantity for all items (plain tiles, decorations and special trims) is one full box.
 I dati relativi agli imballi sono aggiornati al momento della stampa del catalogo e pertanto possono subire variazioni nel corso del tempo.
 Data referring to packaging have been update at time of printing; the actual data may be slightly different.



X20 HANGAR SMOKE 20MM RET 60X120

X20 20MM

BACKSTAGE

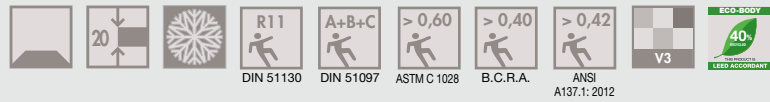

76x76
BK 7622 M BACKSTAGE ASH 20 mm NAT.
 M. 99,00



76x76
BK 7623 M BACKSTAGE GRAPHITE 20 mm NAT.
 M. 99,00

GRES PORCELLANATO A MASSA COLORATA
 FULL BODY COLORED PORCELAIN TILES



20X76X5
BK EL 22 M ELEMENTO L
 BACKSTAGE ASH P. 119,00
BK EL 23 M ELEMENTO L
 BACKSTAGE GRAPHITE P. 119,00

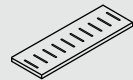

19X76
BK GR 22 M GRIGLIA
 BACKSTAGE ASH P. 199,00
BK GR 23 M GRIGLIA
 BACKSTAGE GRAPHITE P. 199,00

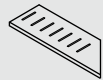

19X76
BK GS 22 M ANG. GRIGLIA SX
 BACKSTAGE ASH P. 259,00
BK GS 23 M ANG. GRIGLIA SX
 BACKSTAGE GRAPHITE P. 259,00

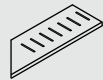

19X76
BK GD 22 M ANG. GRIGLIA DX
 BACKSTAGE ASH P. 259,00
BK GD 23 M ANG. GRIGLIA DX
 BACKSTAGE GRAPHITE P. 259,00

F.to nominale Nominal size	F.to reale (mm) Work size (mm)	Spessore Thickness	Tipologia imballo Type of packing	Lastre/Imballo Slabs/Packing	Pz/Imballo Pcs/Packing	Mq/Scatola Sqm/Box	Kg/Scatola Kg/Box	Scatole/Imballo Box/Packing	Mq totali Sqm total	Kg/Imballo Kg/Packing	Kg totali Kg total	Prezzo imballo Packing Price
76x76 / 30.4"x30.4" nat.	-	20	Pallet	45	1	0,58	29,73	45	26,10	20	1.353	-

I pezzi speciali, per effetto delle lavorazioni, possono presentare variazioni di tonalità. Due to working process, special trims may show variations in tonality.
 L'unità minima di vendita per tutti gli articoli (fondi, decori e pezzi speciali) è la scatola completa. The minimum sales quantity for all items (plain tiles, decorations and special trims) is one full box.
 I dati relativi agli imballi sono aggiornati al momento della stampa del catalogo e pertanto possono subire variazioni nel corso del tempo.
 Data referring to packaging have been update at time of printing; the actual data may be slightly different.

X20 BACKSTAGE ASH 76X76 - ELEMENTO L

X20 20MM

NORDIK STONE

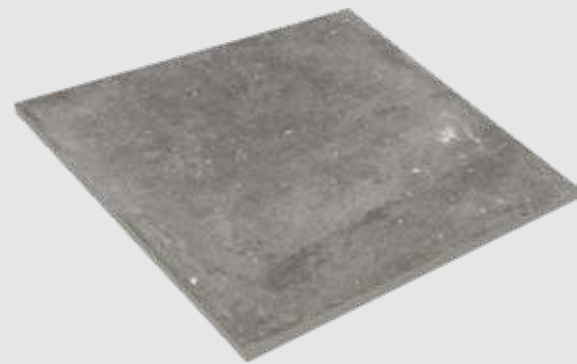
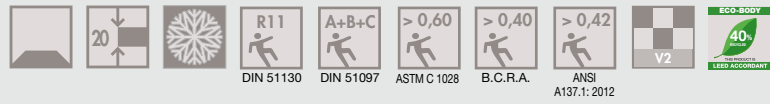

90x90
0004236 NORDIK STONE GREY 20 mm RETT. 
 M. 99,00

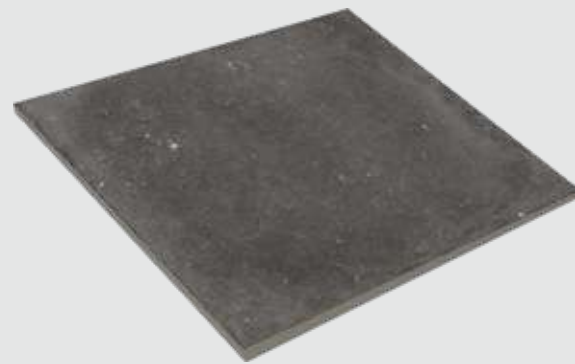

90x90
0004237 NORDIK STONE BLACK 20 mm RETT. 
 M. 99,00



15X90X5
0004239 ELEMENTO L
 NORDIK STONE GREY 20 mm RETT P. 119,00
0004240 ELEMENTO L
 NORDIK STONE BLACK 20 mm RETT P. 119,00

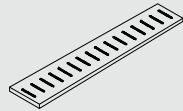

18X90
0004242 GRIGLIA
 NORDIK STONE GREY 20 mm RETT P. 199,00
0004243 GRIGLIA
 NORDIK STONE BLACK 20 mm RETT P. 199,00

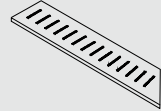

18X90
0004245 ANG. GRIGLIA SX
 NORDIK STONE GREY 20 mm RETT P. 259,00
0004246 ANG. GRIGLIA SX
 NORDIK STONE BLACK 20 mm RETT P. 259,00

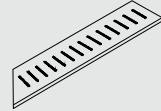

18X90
0004248 ANG. GRIGLIA DX
 NORDIK STONE GREY 20 mm RETT P. 259,00
0004249 ANG. GRIGLIA DX
 NORDIK STONE BLACK 20 mm RETT P. 259,00

F.to nominale	F.to reale (mm)	Spessore	Tipologia imballo	Lastre/Imballo	Pz/Imballo	Mq/Scatola	Kg/Scatola	Scatole/Imballo	Mq totali	Kg/Imballo	Kg totali	Prezzo imballo
Nominal size	Work size (mm)	Thickness	Type of packing	Slabs/Packing	Pcs/Packing	Sqm/Box	Kg/Box	Box/Packing	Sqm total	Kg/Packing	Kg total	Packing Price
90x90 / 36"x36" rett.	896x896	20	Pallet	30	1	0,81	36,60	30	24,30	20	1.118	-

I pezzi speciali, per effetto delle lavorazioni, possono presentare variazioni di tonalità. Due to working process, special trims may show variations in tonality.
 L'unità minima di vendita per tutti gli articoli (fondi, decori e pezzi speciali) è la scatola completa. The minimum sales quantity for all items (plain tiles, decorations and special trims) is one full box.
 I dati relativi agli imballi sono aggiornati al momento della stampa del catalogo e pertanto possono subire variazioni nel corso del tempo.
 Data referring to packaging have been update at time of printing; the actual data may be slightly different.

GRES PORCELLANATO A MASSA COLORATA
 FULL BODY COLORED PORCELAIN TILES



X20 NORDIK STONE BLACK 20 mm RETT. 90X90
 X20 NORDIK WOOD BEIGE 20 mm RETT. 30X120

X20 20MM

STILL NO_W

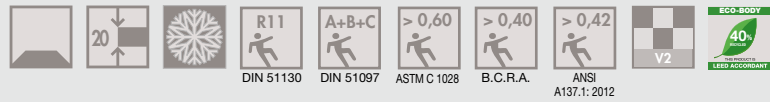

60x120
0000948 SAND 20 mm RETT. 
M. 99,00



60x120
0000949 GRAY 20 mm RETT. 
M. 99,00



60x120
0000950 COAL 20 mm RETT. 
M. 99,00



15X60X5
0001015 ELEMENTO L
SAND 20 mm  P. 89,00
0001016 ELEMENTO L
GRAY 20 mm P. 89,00
0001017 ELEMENTO L
COAL 20 mm P. 89,00

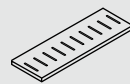

15X60
0001006 GRIGLIA
SAND 20 mm  P. 169,00
0001007 GRIGLIA
GRAY 20 mm P. 169,00
0001008 GRIGLIA
COAL 20 mm P. 169,00

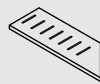

15X60
0001009 ANG. GRIGLIA SX
SAND 20 mm  P. 229,00
0001010 ANG. GRIGLIA SX
GRAY 20 mm P. 229,00
0001011 ANG. GRIGLIA SX
COAL 20 mm P. 229,00

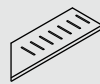

15X60
0001012 ANG. GRIGLIA DX
SAND 20 mm  P. 229,00
0001013 ANG. GRIGLIA DX
GRAY 20 mm P. 229,00
0001014 ANG. GRIGLIA DX
COAL 20 mm P. 229,00

F.to nominale	F.to reale (mm)	Spessore	Tipologia imballo	Lastre/Imballo	Pz/Imballo	Mq/Scatola	Kg/Scatola	Scatole/Imballo	Mq totali	Kg/Imballo	Kg totali	Prezzo imballo
Nominal size	Work size (mm)	Thickness	Type of packing	Slabs/Packing	Pcs/Packing	Sqm/Box	Kg/Box	Box/Packing	Sqm total	Kg/Packing	Kg total	Packing Price
60x120 / 24"x48" rett.	600x1200	20	Pallet	27	1	0,72	34,36	27	19,44	20	943	-

I pezzi speciali, per effetto delle lavorazioni, possono presentare variazioni di tonalità. Due to working process, special trims may show variations in tonality.
L'unità minima di vendita per tutti gli articoli (fondi, decori e pezzi speciali) è la scatola completa. The minimum sales quantity for all items (plain tiles, decorations and special trims) is one full box.
I dati relativi agli imballi sono aggiornati al momento della stampa del catalogo e pertanto possono subire variazioni nel corso del tempo.
Data referring to packaging have been update at time of printing; the actual data may be slightly different.



X20 STILL NO_W COAL 20 mm RETT. 60X120

X20 20MM

NO_W

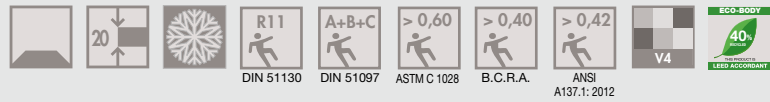

76x76
NO 7622 M NO_W GRAY 20mm NAT.
M. 99,00



76x76
NO 7630 M NO_W SAND 20mm NAT.
M. 99,00



20X76X5
NO EL 22 M ELEMENTO L
NO_W GRAY P. 119,00
NO EL 30 M ELEMENTO L
NO_W SAND P. 119,00

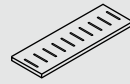

19X76
NO GR 22 M GRIGLIA
NO_W GRAY P. 199,00
NO GR 30 M GRIGLIA
NO_W SAND P. 199,00



19X76
NO GS 22 M ANG. GRIGLIA SX
NO_W GRAY P. 259,00
NO GS 30 M ANG. GRIGLIA SX
NO_W SAND P. 259,00

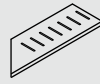

19X76
NO GD 22 M ANG. GRIGLIA DX
NO_W GRAY P. 259,00
NO GD 30 M ANG. GRIGLIA DX
NO_W SAND P. 259,00



F.to nominale	F.to reale (mm)	Spessore	Tipologia imballo	Lastre/Imballo	Pz/Imballo	Mq/Scatola	Kg/Scatola	Scatole/Imballo	Mq totali	Kg/Imballo	Kg totali	Prezzo imballo
Nominal size	Work size (mm)	Thickness	Type of packing	Slabs/Packing	Pcs/Packing	Sqm/Box	Kg/Box	Box/Packing	Sqm total	Kg/Packing	Kg total	Packing Price
76x76 / 30.4"x30.4" nat.	-	20	Pallet	45	1	0,58	29,73	45	26,10	20	1.353	-

I pezzi speciali, per effetto delle lavorazioni, possono presentare variazioni di tonalità. Due to working process, special trims may show variations in tonality.
L'unità minima di vendita per tutti gli articoli (fondi, decori e pezzi speciali) è la scatola completa. The minimum sales quantity for all items (plain tiles, decorations and special trims) is one full box.
I dati relativi agli imballi sono aggiornati al momento della stampa del catalogo e pertanto possono subire variazioni nel corso del tempo.
Data referring to packaging have been update at time of printing; the actual data may be slightly different.



X20 NO_W GRAY 20 mm 76X76

X20 20MM

FORWARD

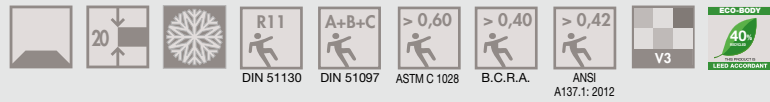

40x80
FW 4830 M FORWARD EARTH 20 mm. NAT.
 M. 93,00



40x80
FW 4822 M FORWARD GREY 20 mm. NAT.
 M. 93,00

GRES PORCELLANATO A MASSA COLORATA
 FULL BODY COLORED PORCELAIN TILES

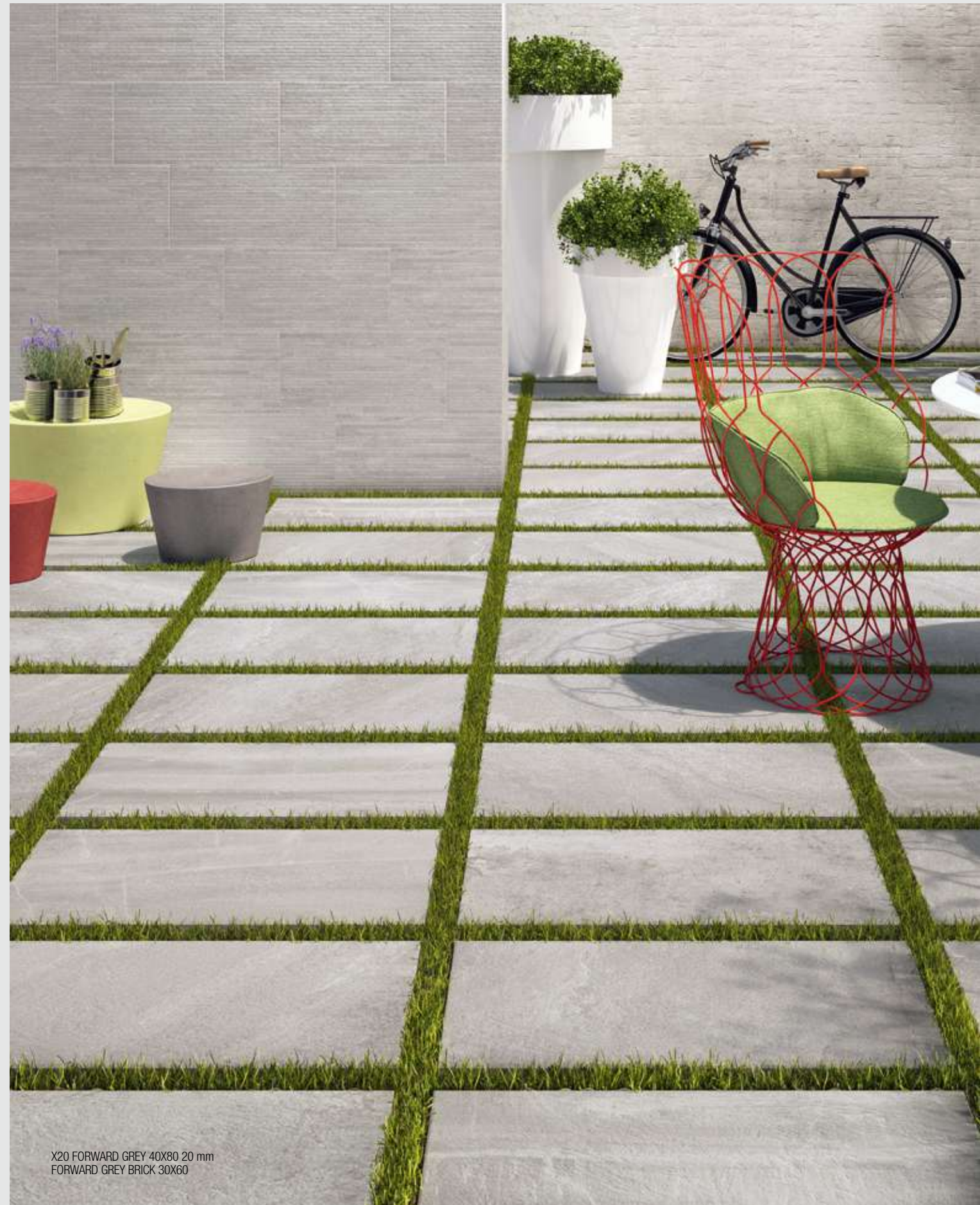

X20 FORWARD GREY 40X80 20 mm
 FORWARD GREY BRICK 30X60



20X40X5
FW EL 30 M ELEMENTO L
 FORWARD EARTH P. 63,00
FW EL 22 M ELEMENTO L
 FORWARD GREY P. 63,00

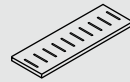

20X80
FW GR 30 M GRIGLIA
 FORWARD EARTH P. 219,00
FW GR 22 M GRIGLIA
 FORWARD GREY P. 219,00



20X80
FW GS 30 M ANG. GRIGLIA SX
 FORWARD EARTH P. 299,00
FW GS 22 M ANG. GRIGLIA SX
 FORWARD GREY P. 299,00

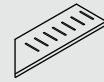

20X80
FW GD 30 D ANG. GRIGLIA DX
 FORWARD EARTH P. 299,00
FW GD 22 M ANG. GRIGLIA DX
 FORWARD GREY P. 299,00

F.to nominale	F.to reale (mm)	Spessore	Tipologia imballo	Lastre/Imballo	Pz/Imballo	Mq/Scatola	Kg/Scatola	Scatole/Imballo	Mq totali	Kg/Imballo	Kg totali	Prezzo imballo
Nominal size	Work size (mm)	Thickness	Type of packing	Slabs/Packing	Pcs/Packing	Sqm/Box	Kg/Box	Box/Packing	Sqm total	Kg/Packing	Kg total	Packing Price
40x80 / 16"x32" nat.	-	20	Pallet	48	2	0,64	28,26	24	15,36	20	698	-

I pezzi speciali, per effetto delle lavorazioni, possono presentare variazioni di tonalità. Due to working process, special trims may show variations in tonality.
 L'unità minima di vendita per tutti gli articoli (fondi, decori e pezzi speciali) è la scatola completa. The minimum sales quantity for all items (plain tiles, decorations and special trims) is one full box.
 I dati relativi agli imballi sono aggiornati al momento della stampa del catalogo e pertanto possono subire variazioni nel corso del tempo.
 Data referring to packaging have been update at time of printing; the actual data may be slightly different.

X20 20MM

SHADOW

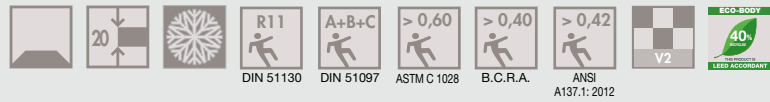

76x76
SH 7622 M SHADOW SMOKE 20 mm NAT. 
M. 99,00



76x76
SH 7690 M SHADOW NIGHT 20 mm NAT. 
M. 99,00

GRES PORCELLANATO A MASSA COLORATA
FULL BODY COLORED PORCELAIN TILES



20X76X5
SH EL 22 M ELEMENTO L
SHADOW SMOKE P. 119,00
SH EL 90 M ELEMENTO L
SHADOW NIGHT P. 119,00

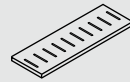

19X76
SH GR 22 M GRIGLIA
SHADOW SMOKE P. 199,00
SH GR 90 M GRIGLIA
SHADOW NIGHT P. 199,00

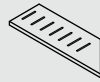

19X76
SH GS 22 M ANG. GRIGLIA SX
SHADOW SMOKE P. 259,00
SH GS 90 M ANG. GRIGLIA SX
SHADOW NIGHT P. 259,00

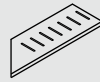

19X76
SH GD 22 M ANG. GRIGLIA DX
SHADOW SMOKE P. 259,00
SH GD 90 M ANG. GRIGLIA DX
SHADOW NIGHT P. 259,00

F.to nominale	F.to reale (mm)	Spessore	Tipologia imballo	Lastre/Imballo	Pz/Imballo	Mq/Scatola	Kg/Scatola	Scatole/Imballo	Mq totali	Kg/Imballo	Kg totali	Prezzo imballo
Nominal size	Work size (mm)	Thickness	Type of packing	Slabs/Packing	Pcs/Packing	Sqm/Box	Kg/Box	Box/Packing	Sqm total	Kg/Packing	Kg total	Packing Price
76x76 / 30.4"x30.4" nat.	-	20	Pallet	45	1	0,58	29,73	45	26,10	20	1.353	-

I pezzi speciali, per effetto delle lavorazioni, possono presentare variazioni di tonalità. Due to working process, special trims may show variations in tonality.
L'unità minima di vendita per tutti gli articoli (fondi, decori e pezzi speciali) è la scatola completa. The minimum sales quantity for all items (plain tiles, decorations and special trims) is one full box.
I dati relativi agli imballi sono aggiornati al momento della stampa del catalogo e pertanto possono subire variazioni nel corso del tempo.
Data referring to packaging have been update at time of printing; the actual data may be slightly different.

X20 20MM

NORDIK WOOD

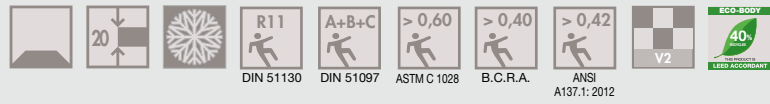

30x120
0004815 NORDIK WOOD BEIGE 20 mm RETT. 
 M. 99,00

30x120
0004816 NORDIK WOOD GOLD 20 mm RETT. 
 M. 99,00



15X60X5
0004817 ELEMENTO L
 NORDIK WOOD BEIGE 20 mm P. 89,00
0004818 ELEMENTO L
 NORDIK WOOD GOLD 20 mm P. 89,00

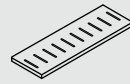

15X60
0004819 GRIGLIA
 NORDIK WOOD BEIGE 20 mm P. 169,00
0004820 GRIGLIA
 NORDIK WOOD GOLD 20 mm P. 169,00

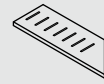

15X60
0004821 ANG. GRIGLIA SX
 NORDIK WOOD BEIGE 20 mm P. 229,00
0004822 ANG. GRIGLIA SX
 NORDIK WOOD GOLD 20 mm P. 229,00

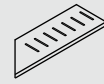

15X60
0004823 ANG. GRIGLIA DX
 NORDIK WOOD BEIGE 20 mm P. 229,00
0004824 ANG. GRIGLIA DX
 NORDIK WOOD GOLD 20 mm P. 229,00

F.to nominale Nominal size	F.to reale (mm) Work size (mm)	Spessore Thickness	Tipologia imballo Type of packing	Lastre/Imballo Slabs/Packing	Pz/Imballo Pcs/Packing	Mq/Scatola Sqm/Box	Kg/Scatola Kg/Box	Scatole/Imballo Box/Packing	Mq totali Sqm total	Kg/Imballo Kg/Packing	Kg totali Kg total	Prezzo imballo Packing Price
60x120 / 24"x48" rett.	296x1195,5	20	Pallet	72	2	0,72	32,00	36	25,92	20	1.172	-

I pezzi speciali, per effetto delle lavorazioni, possono presentare variazioni di tonalità. Due to working process, special trims may show variations in tonality.
 L'unità minima di vendita per tutti gli articoli (fondi, decori e pezzi speciali) è la scatola completa. The minimum sales quantity for all items (plain tiles, decorations and special trims) is one full box.
 I dati relativi agli imballi sono aggiornati al momento della stampa del catalogo e pertanto possono subire variazioni nel corso del tempo.
 Data referring to packaging have been update at time of printing; the actual data may be slightly different.

X20 NORDIK WOOD GOLD 20 mm RETT. 30X120

X20 20MM

COZY

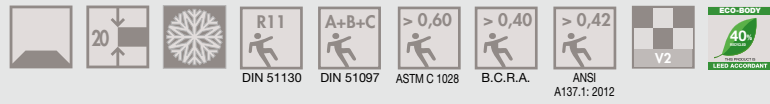

30X120
0003084 COZY HAVANA 20 mm RETT. 
 M. 99,00

30X120
0003085 COZY BARK 20 mm RETT. 
 M. 99,00

GRES PORCELLANATO A MASSA COLORATA
 FULL BODY COLORED PORCELAIN TILES

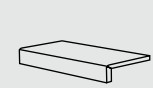

15X60X5
0003105 ELEMENTO L
 COZY HAVANA P. 89,00
0003106 ELEMENTO L
 COZY BARK P. 89,00

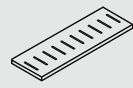

15X60
0003107 GRIGLIA
 COZY HAVANA P. 169,00
0003108 GRIGLIA
 COZY BARK P. 169,00



15X60
0003109 ANG. GRIGLIA SX
 COZY HAVANA P. 229,00
0003110 ANG. GRIGLIA SX
 COZY BARK P. 229,00

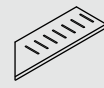

15X60
0003111 ANG. GRIGLIA DX
 COZY HAVANA P. 229,00
0003112 ANG. GRIGLIA DX
 COZY BARK P. 229,00

F.to nominale	F.to reale (mm)	Spessore	Tipologia imballo	Lastre/Imballo	Pz/Imballo	Mq/Scatola	Kg/Scatola	Scatole/Imballo	Mq totali	Kg/Imballo	Kg totali	Prezzo imballo
Nominal size	Work size (mm)	Thickness	Type of packing	Slabs/Packing	Pcs/Packing	Sqm/Box	Kg/Box	Box/Packing	Sqm total	Kg/Packing	Kg total	Packing Price
30x120 / 12"x48" rett.	295x1195	20	Pallet	72	2	0,72	32,65	36	25,92	20	1.190	-

I pezzi speciali, per effetto delle lavorazioni, possono presentare variazioni di tonalità. Due to working process, special trims may show variations in tonality.
 L'unità minima di vendita per tutti gli articoli (fondi, decori e pezzi speciali) è la scatola completa. The minimum sales quantity for all items (plain tiles, decorations and special trims) is one full box.
 I dati relativi agli imballi sono aggiornati al momento della stampa del catalogo e pertanto possono subire variazioni nel corso del tempo.
 Data referring to packaging have been update at time of printing; the actual data may be slightly different.

X20 COZY HAVANA RETT. 30X120 20MM

X20 20MM

PLACE_2B

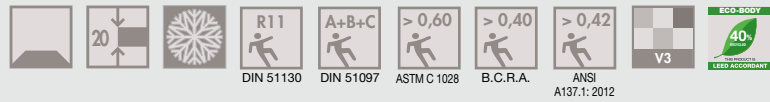

30X120
DB 3123 M DUBLIN TAUPE 20 mm RETT. 
M. 99,00

30X120
AN 3130 M ASPEN HAVANA 20 mm RETT. 
M. 99,00

GRES PORCELLANATO A MASSA COLORATA
FULL BODY COLORED PORCELAIN TILES



15X60X5
DB EL 23 M ELEMENTO L
DUBLIN TAUPE P. 89,00
AN EL 30 M ELEMENTO L
ASPEN HAVANA P. 89,00

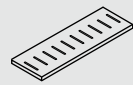

15X60
DB GR 23 M GRIGLIA
DUBLIN TAUPE P. 169,00
AN GR 30 M GRIGLIA
ASPEN HAVANA P. 169,00



15X60
DB GS 23 M ANG. GRIGLIA SX
DUBLIN TAUPE P. 229,00
AN GS 30 M ANG. GRIGLIA SX
ASPEN HAVANA P. 229,00

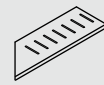

15X60
DB GD 23 M ANG. GRIGLIA DX
DUBLIN TAUPE P. 229,00
AN GD 30 M ANG. GRIGLIA DX
ASPEN HAVANA P. 229,00

F.to nominale	F.to reale (mm)	Spessore	Tipologia imballo	Lastre/Imballo	Pz/Imballo	Mq/Scatola	Kg/Scatola	Scatole/Imballo	Mq totali	Kg/Imballo	Kg totali	Prezzo imballo
Nominal size	Work size (mm)	Thickness	Type of packing	Slabs/Packing	Pcs/Packing	Sqm/Box	Kg/Box	Box/Packing	Sqm total	Kg/Packing	Kg total	Packing Price
30x120 / 12"x48" rett.	295x1200	20	Pallet	64	2	0,72	33,62	32	23,04	20	1.096	-

I pezzi speciali, per effetto delle lavorazioni, possono presentare variazioni di tonalità. Due to working process, special trims may show variations in tonality.
L'unità minima di vendita per tutti gli articoli (fondi, decori e pezzi speciali) è la scatola completa. The minimum sales quantity for all items (plain tiles, decorations and special trims) is one full box.
I dati relativi agli imballi sono aggiornati al momento della stampa del catalogo e pertanto possono subire variazioni nel corso del tempo.
Data referring to packaging have been update at time of printing; the actual data may be slightly different.

X20 DUBLIN TAUPE RETT. 30X120 - GRIGLIA - ANG. GRIGLIA SX/DX

X20 20MM

DAKOTA

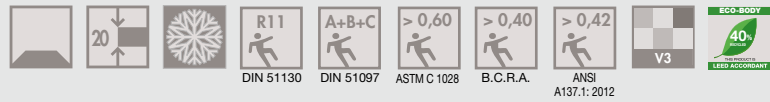

30X120
DK 3113 M DAKOTA NATURALE 20 mm RETT.
 M. 99,00

30X120
DK 3130 M DAKOTA AVANA 20 mm RETT.
 M. 99,00



15X60X5
DK EL 13 M ELEMENTO L
 DAKOTA NATURALE P. 89,00
DK EL 30 M ELEMENTO L
 DAKOTA AVANA P. 89,00

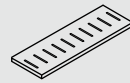

15X60
DK GR 13 M GRIGLIA
 DAKOTA NATURALE P. 169,00
DK GR 30 M GRIGLIA
 DAKOTA AVANA P. 169,00



15X60
DK GS 13 M ANG. GRIGLIA SX
 DAKOTA NATURALE P. 229,00
DK GS 30 M ANG. GRIGLIA SX
 DAKOTA AVANA P. 229,00

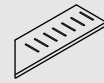

15X60
DK GD 13 M ANG. GRIGLIA DX
 DAKOTA NATURALE P. 229,00
DK GD 30 M ANG. GRIGLIA DX
 DAKOTA AVANA P. 229,00

F.to nominale	F.to reale (mm)	Spessore	Tipologia imballo	Lastre/Imballo	Pz/Imballo	Mq/Scatola	Kg/Scatola	Scatole/Imballo	Mq totali	Kg/Imballo	Kg totali	Prezzo imballo
Nominal size	Work size (mm)	Thickness	Type of packing	Slabs/Packing	Pcs/Packing	Sqm/Box	Kg/Box	Box/Packing	Sqm total	Kg/Packing	Kg total	Packing Price
30x120 / 12"x48" rett.	295x1200	20	Pallet	64	2	0,72	33,62	32	23,04	20	1.096	-

I pezzi speciali, per effetto delle lavorazioni, possono presentare variazioni di tonalità. Due to working process, special trims may show variations in tonality.
 L'unità minima di vendita per tutti gli articoli (fondi, decori e pezzi speciali) è la scatola completa. The minimum sales quantity for all items (plain tiles, decorations and special trims) is one full box.
 I dati relativi agli imballi sono aggiornati al momento della stampa del catalogo e pertanto possono subire variazioni nel corso del tempo.
 Data referring to packaging have been update at time of printing; the actual data may be slightly different.



X20 DAKOTA NATURALE 30X120 - GRIGLIA - ANG. GRIGLIA SX/DX

X20_{20 MM}



POSA TRADIZIONALE TRADITIONAL INSTALLATION



La posa tradizionale è ideale per la realizzazione di pavimentazioni carrabili. Traditional installation is ideal for floorings that will be driven over by vehicles.

POSA A SECCO SU SABBIA DRY INSTALLATION ON SAND



La posa su sabbia permette di creare percorsi e camminamenti per spiagge e stabilimenti balneari. Installing on top of sand is ideal for creating paths and walkways on beaches and beach bars.

POSA A SECCO SU GHIAIA DRY INSTALLATION ON GRAVEL



La posa su ghiaia permette il perfetto drenaggio delle acque piovane. Installing on gravel enables perfect drainage of rainwater.

POSA SOPRAELEVATA DA ESTERNO OUTDOOR RAISED LAYING SYSTEM



Il sistema di pavimentazione sopraelevata prevede l'utilizzo di supporti portanti di tipo autolivellante, regolabili oppure fissi che si adattano con semplicità e sicurezza ad ogni tipo di pavimento sottostante. Il sistema permette la realizzazione di piani di posa con altezze variabili, da terra, comprese fra 25 e 270 mm. L'indipendenza della pavimentazione dai supporti garantisce l'assorbimento di eventuali movimenti strutturali. Il sistema sopraelevato non necessita di massetto in cemento e consente una diminuzione del peso sulla struttura portante. Le fughe aperte tra una piastrella ed un'altra consentono un facile deflusso dell'acqua piovana evitando tutti i rischi di accumulo o di ristagno. La presenza dell'intercapedine fra il piano di calpestio e il piano di appoggio favorisce l'aerazione e l'isolamento termico. Questa soluzione permette inoltre il passaggio di impianti e tubazioni nell'intercapedine, e la facile ispezione degli stessi una volta installata la pavimentazione.

The raised floor system foresees the use of self-levelling, adjustable or fixed load bearing supports that easily adapt to the floor below in total safety. The system is suitable to create laying designs with variable heights from the ground, which range between 25 and 270 mm. The independence of the flooring from the supports guarantees the absorption of any structural movements. The raised system does not require a cement screed and reduces the load on the bearing structure. The open joints between the tiles allow rainwater to easily drain off, avoiding any risk of water accumulation or stagnation. The gap between the tread surface and the support surface favours ventilation and heat insulation. This solution allows for the installation of systems and piping in the gap, which can be easily inspected even once the floor has been installed.

POSA A SECCO SU ERBA DRY INSTALLATION ON GRASS



La posa diretta su erba permette di creare percorsi e camminamenti integrandosi perfettamente nell'ambiente. Installing directly on top of grass enables the creation of paths and walkways that blend in perfectly with the surroundings.

CONSUMO SUPPORTI PER PAVIMENTAZIONE SOPRAELEVATA SUPPORTS FOR RAISED LAYING SYSTEM USAGE

Formato Piastrella Tile size	Posa lineare Linear laying	Posa alternate Alternate laying
40x80 / 16"x32"	6,25 pz/m ²	6,25 pz/m ²
30x120 / 12"x48"	5,6 pz/m ²	5,6 pz/m ²
60x120 / 24"x48"	2,78 pz/m ²	2,78 pz/m ²
76x76 / 30.4"x30.4"	6,93 pz/m ²	6,93 pz/m ²
90x90 / 36"x36"	5 pz/m ²	5 pz/m ²

N.B il calcolo tiene conto di un supporto centrale in corrispondenza del lato lungo della piastrella.
N.B the calculation takes into account a central support at the long side of the tile.

ES. : POSA LINEARE EX. : LINEAR LAYING

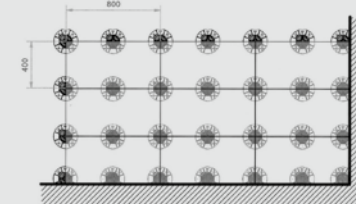

40x80 cm (16"x32")

ES. : POSA ALTERNATA EX. : ALTERNATE LAYING

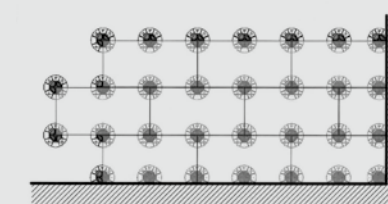

40x80 cm (16"x32")

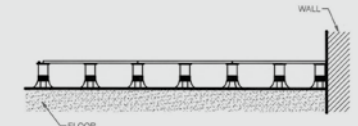

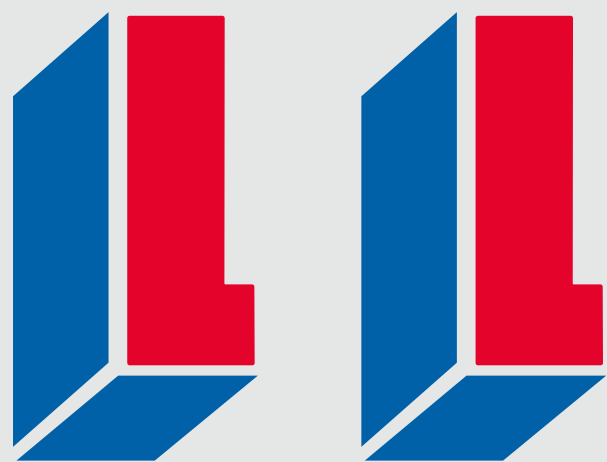

CONTEMPORARY WALL TILES

RIVESTIMENTI
CONTEMPORANEI

260 W_ALL TONES
268 W_ALL

W_ALL TONES



PASTA BIANCA DA RIVESTIMENTO / WHITE BODY WALL TILES

SUPERFICI / SURFACES



Naturale
Natural

FORMATI / SIZES



7 mm

30x120
12"x48"



W_ALL TONES SAGE 30X120,
COZY HAVANA 20X120



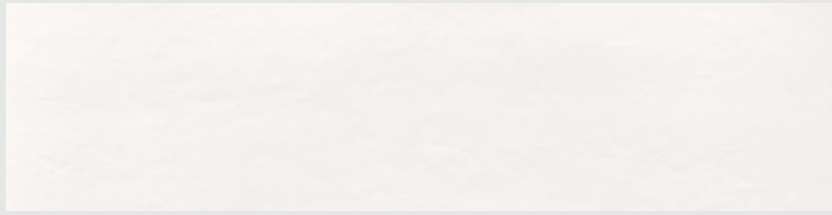

30X120 RETT. **WA 3110W** W_ALL WHITE

M. 70,00

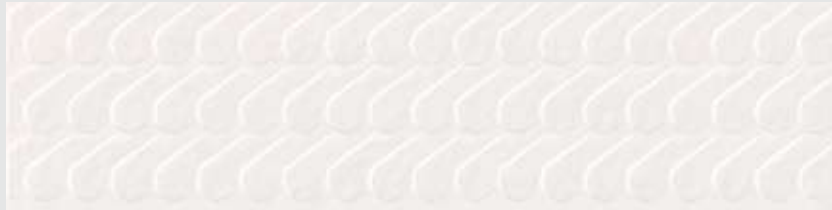

30X120 RETT. **0004329** W_ALL TONES BISQUIT WHITE

M. 82,00

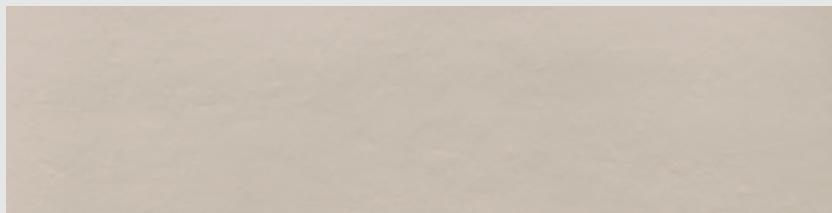

30X120 RETT. **0004328** W_ALL TONES SAND

M. 70,00

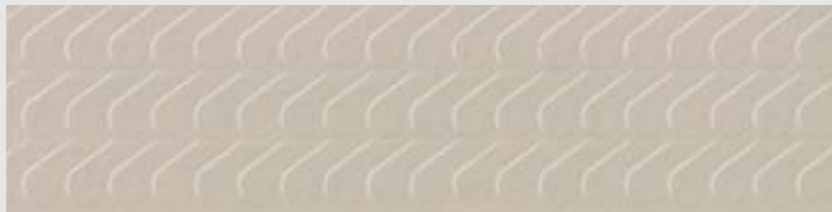

30X120 RETT. **0004340** W_ALL TONES BISQUIT SAND

M. 82,00

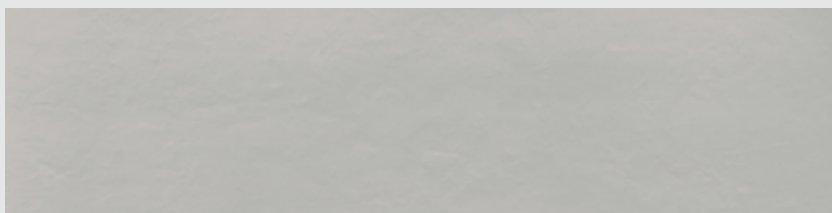

30X120 RETT. **0004333** W_ALL TONES OYSTER

M. 70,00

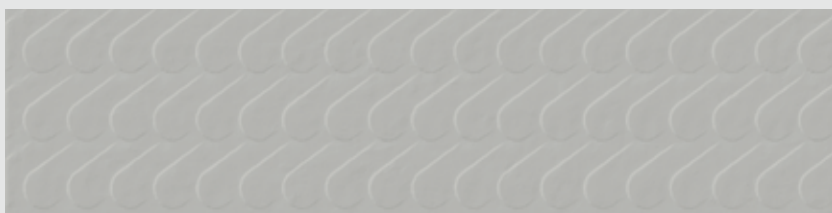

30X120 RETT. **0004341** W_ALL TONES BISQUIT OYSTER

M. 82,00



30X120 RETT. **0004329** W_ALL TONES NUTMEG

M. 70,00



30X120 RETT. **0004330** W_ALL TONES DUSTY BLUE

M. 70,00

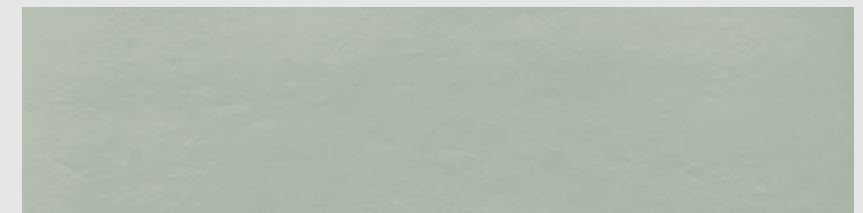

30X120 RETT. **0004331** W_ALL TONES SAGE

M. 70,00

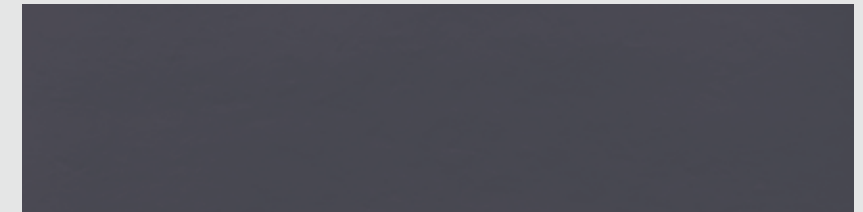

30X120 RETT. **0004332** W_ALL TONES SHADOW

M. 70,00

La non perfetta continuità di linee, rilievi o motivi grafici tra piastrelle adiacenti è naturale conseguenza del processo produttivo, pertanto non costituisce un vizio del prodotto

Any variations in graphic designs or textures between adjacent tiles are a natural consequence of the manufacturing process and do not constitute a product defect.



* 30X120 RETT. **0004335** W_ALL TONES TANGRAM M. 82,00



* 5X120 RETT. **0004597** W_ALL TONES LISTELLO TANGRAM P.10,00

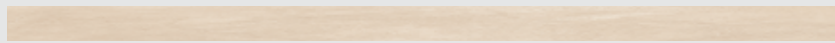

* 5X120 RETT. **0000395** W_ALL TONES LIST. WOOD BEIGE P.10,00

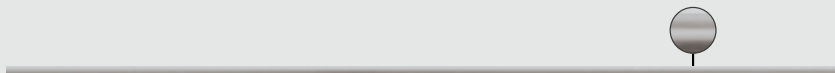

0,5x120 **0000086** MATITA ALLUMINIO P. 20,90

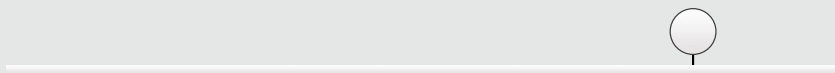

0,5x120 **0000087** MATITA ALLUMINIO WHITE P. 34,90



0,5x120 **0000088** MATITA ALLUMINIO BLACK P. 34,90

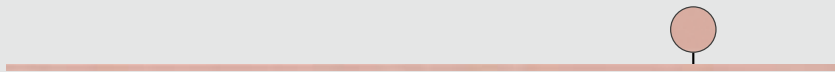

0,5x120 **0000556** MATITA ALLUMINIO RAME P. 34,90

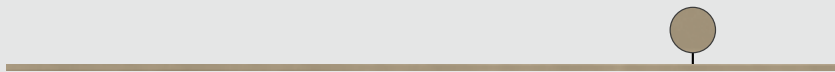

0,5x120 **0000557** MATITA ALLUMINIO BRONZO P. 34,90

Articoli realizzati in alluminio per l'uso a parete, adatti a raccordare piastrelle di diverso spessore (9 mm / 7 mm).
Aluminium strip for use between wall tiles of different thicknesses (9 mm / 7 mm).

* La non perfetta continuità di linee, rilievi o motivi grafici tra piastrelle adiacenti è naturale conseguenza del processo produttivo, pertanto non costituisce un vizio del prodotto.

Any variations in graphic designs or textures between adjacent tiles are a natural consequence of the manufacturing process and do not constitute a product defect.



W_ALL TONES WHITE 30X120, DUSTY BLUE 30X120, DEC. TANGRAM 30X120,
LIST. TANGRAM, HYPER SILVER, NORDIK WOOD SMOKED 20X120

PASTA BIANCA DA RIVESTIMENTO - CLASSIFICAZIONE SECONDO NORME EN 14411 (ISO 13006) ALLEGATO G GRUPPO BI1b
WHITE BODY WALL TILES - CLASSIFICATION IN ACCORDANCE WITH EN 14411 (ISO 13006) ANNEX G GROUP BI1b

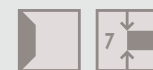

F.to nominale Nominal size	F.to reale (mm) Work size (mm)	Spessore Thickness	Tipologia imballo Type of packing	Lastre/Imballo Slabs/Packing	Pz/Imballo Pcs/Packing	Mq/Scatola Sqm/Box	Kg/Scatola Kg/Box	Scatole/Imballo Box/Packing	Mq total Sqm total	Kg/Imballo Kg/Packing	Kg total Kg total	Prezzo imballo Packing Price
30x120 / 12"x48" rett.	297x1194	7	Pallet	160	4	1,44	23,00	40	57,60	20	940	-

I dati relativi agli imballi sono aggiornati al momento della stampa del catalogo e pertanto possono subire variazioni nel corso del tempo.
Data referring to packaging have been update at time of printing; the actual data may be slightly different.

W_ALL

W&P™

PASTA BIANCA DA RIVESTIMENTO / WHITE BODY WALL TILES

SUPERFICI / SURFACES



Naturale
Natural

FORMATI / SIZES



60x120
24"x48"



30x120
12"x48"

7 mm

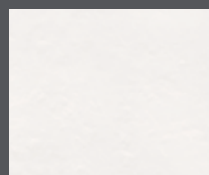

WHITE

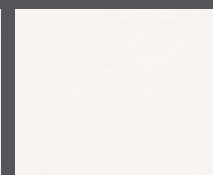

MILK

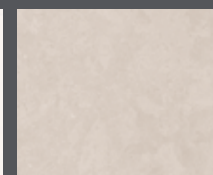

STONE BEIGE

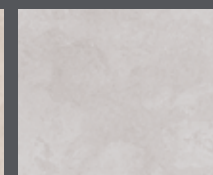

STONE GRIGIO

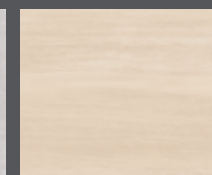

WOOD BEIGE

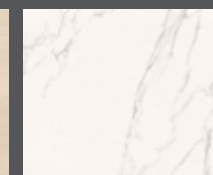

STATUARIO

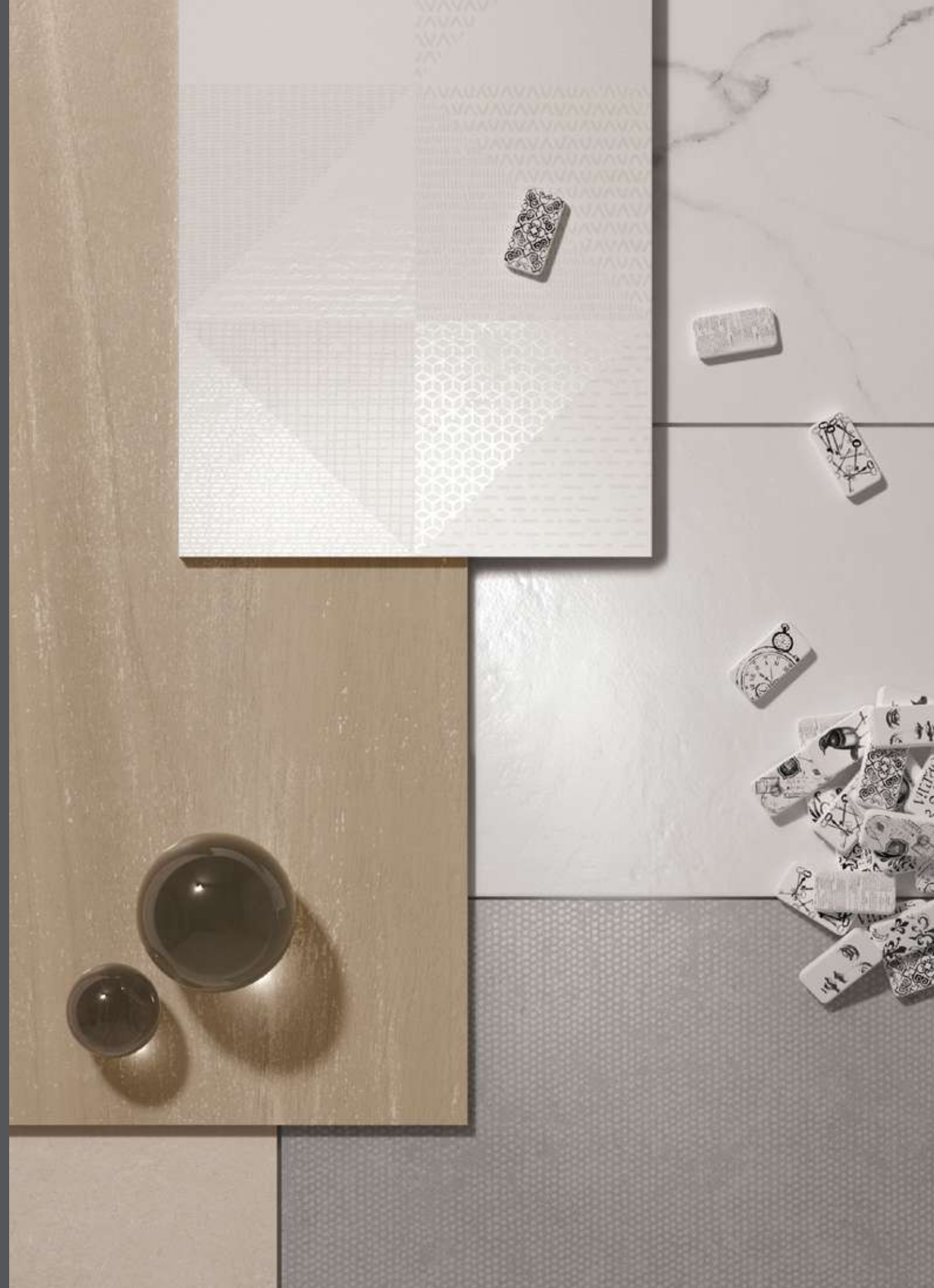



W_ALL STONE DRAW BEIGE 30X120



W_ALL MILK 30X120 / MILK SKETCH 30X120 / MATITA ALLUMINIO BLACK 0.5X120
BACKSTAGE GRAPHITE 60X60



W_ALL STONE DRAW GRIGIO 30X120 / STONE GRIGIO 30X120 / WOOD BEIGE 30X120
STILL NO_W GRAY 80X80



60x120 RETT. **WA 6110 W** W_ALL WHITE

M. 70,00

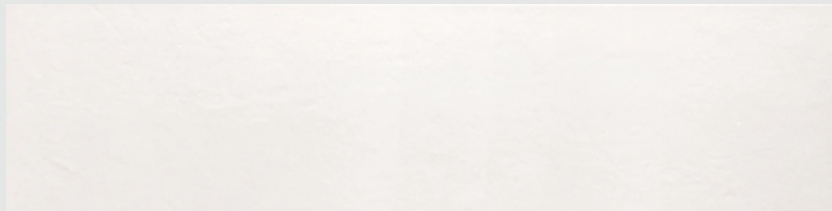

30x120 RETT. **WA 3110 W** W_ALL WHITE

M. 70,00



30x120 RETT. **WA 3110 S** W_ALL WHITE PLEATS

M. 82,00



0,5x120 **0000086** MATITA ALLUMINIO

P. 20,90

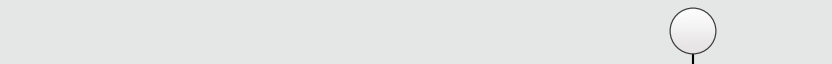

0,5x120 **0000087** MATITA ALLUMINIO WHITE

P. 34,90



0,5x120 **0000088** MATITA ALLUMINIO BLACK

P. 34,90

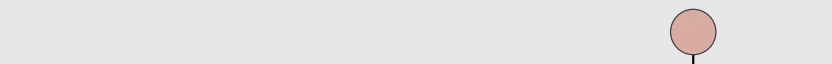

0,5x120 **0000556** MATITA ALLUMINIO RAME

P. 34,90

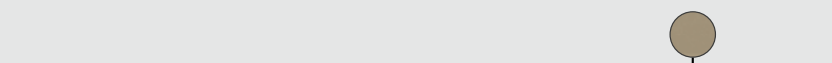

0,5x120 **0000557** MATITA ALLUMINIO BRONZO

P. 34,90

Articoli realizzati in alluminio per l'uso a parete, adatti a raccordare piastrelle di diverso spessore (9 mm / 7 mm).
Aluminium strip for use between wall tiles of different thicknesses (9 mm / 7 mm).



60x120 RETT. **WA 6111 W** W_ALL MILK

M. 70,00

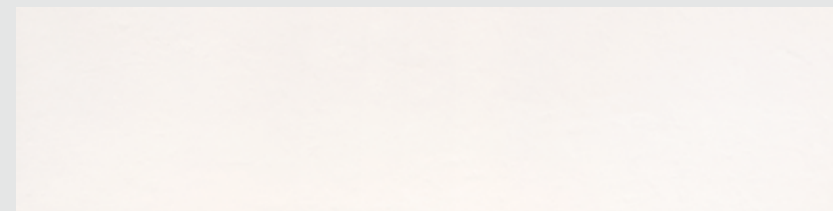

30x120 RETT. **WA 3111 W** W_ALL MILK RETT

M. 70,00



30x120 RETT. **WA 3111 S** W_ALL MILK RELIEF

M. 82,00



30x120 RETT. **WA 3111 D** W_ALL MILK SKETCH

M. 82,00

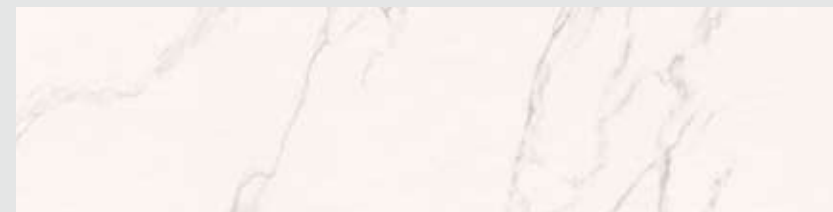

30x120 RETT. **WA 3112 W** W_ALL STATUARIO

M. 70,00

La non perfetta continuità di linee, rilievi o motivi grafici tra piastrelle adiacenti è naturale conseguenza del processo produttivo, pertanto non costituisce un vizio del prodotto

Any variations in graphic designs or textures between adjacent tiles are a natural consequence of the manufacturing process and do not constitute a product defect.

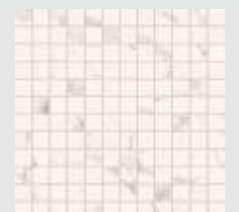

30x30
WA MO 121 W_ALL STATUARIO MOS.
M. 199,00





30x120 RETT. **WA 3130 W** W_ALL STONE BEIGE

M. 70,00

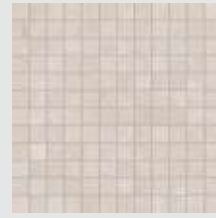

30x30
WA MO 301 W_ALL STONE MOS. BEIGE
M. 199,00



30x120 RETT. **WA 3122 W** W_ALL STONE GRIGIO

M. 70,00

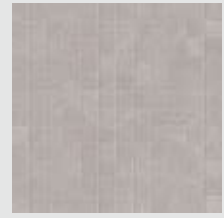

30x30
WA MO 221 W_ALL STONE MOS. GRIGIO
M. 199,00



30x120 RETT. **WA 3130 S** W_ALL RELIEF BEIGE

M. 82,00



30x120 RETT. **WA 3122 S** W_ALL STONE RELIEF GRIGIO

M. 82,00

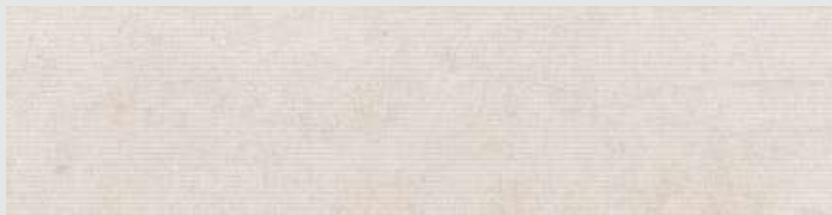

30x120 RETT. **WA 3130 D** W_ALL DRAW BEIGE

M. 82,00



30x120 RETT. **WA 3122 D** W_ALL STONE DRAW GRIGIO

M. 82,00



30x120 RETT. **0000394** WOOD BEIGE

M. 70,00



5x120 RETT. **0000395** LIST. WOOD BEIGE



P. 10,00

La non perfetta continuità di linee, rilievi o motivi grafici tra piastrelle adiacenti è naturale conseguenza del processo produttivo, pertanto non costituisce un vizio del prodotto

Any variations in graphic designs or textures between adjacent tiles are a natural consequence of the manufacturing process and do not constitute a product defect.

PASTA BIANCA DA RIVESTIMENTO - CLASSIFICAZIONE SECONDO NORME EN 14411 (ISO 13006) ALLEGATO G GRUPPO B11b
WHITE BODY WALL TILES - CLASSIFICATION IN ACCORDANCE WITH EN 14411 (ISO 13006) ANNEX G GROUP B11b



F.to nominale Nominal size	F.to reale (mm) Work size (mm)	Spessore Thickness	Tipologia imballo Type of packing	Lastre/Imballo Slabs/Packing	Pz/Imballo Pcs/Packing	Mq/Scatola Sqm/Box	Kg/Scatola Kg/Box	Scatole/Imballo Box/Packing	Mq totali Sqm total	Kg/Imballo Kg/Packing	Kg totali Kg total	Prezzo imballo Packing Price
60x120 / 24"x48" rett.	596x1194	7	Pallet	64	2	1,44	23,00	32	46,08	20	756	-
30x120 / 12"x48" rett.	297x1194	7	Pallet	160	4	1,44	23,00	40	57,60	20	940	-
30x120 / 12"x48" RELIEF	297x1194	7	Pallet	144	4	1,44	23,00	36	51,84	20	848	-

I dati relativi agli imballi sono aggiornati al momento della stampa del catalogo e pertanto possono subire variazioni nel corso del tempo.
Data referring to packaging have been update at time of printing; the actual data may be slightly different.



TECHNICAL INFORMATION

INFORMAZIONI TECNICHE

- 278 WIDE
- 284 AUTOLEVELING / INSTA-TILE
- 286 GRADONE JOLLY
- 287 W&P
- 288 CONSIGLI POSA E PULIZIA
INSTALLATION AND CLEANING ADVICE
- 292 CARATTERISTICHE TECNICHE
TECHNICAL CHARACTERISTICS
- 294 ECOSOSTENIBILITÀ
ECO-SUSTAINABILITY
- 294 GUIDA ALLA CONSULTAZIONE
CONSULTATION GUIDE
- 295 CONDIZIONI GENERALI DI VENDITA
GENERAL SALES TERMS AND CONDITIONS

CERAMIC R-EVOLUTION

Il progetto WIDE FLAVIKER parte dalla rivoluzionaria tecnologia produttiva CONTINUA+, che permette di produrre lastre in gres porcellanato robuste e leggere allo stesso tempo, grazie allo spessore ridotto di 6 e 7 mm, fino alla dimensione record di 160x320 cm. Il nuovo sistema di pressatura prevede la compattazione a secco delle materie prime e consente di ottenere superfici particolarmente apprezzabili sia per la qualità estetica che per le performance tecniche.

FLAVIKER's WIDE collection consists of tough yet lightweight porcelain slabs with a thickness of just 6 and 7 mm and a record size of 160x320 cm produced using the revolutionary CONTINUA+ technology. The new pressing system involves dry compaction of raw materials and is able to produce surfaces that combine excellent aesthetic quality with outstanding technical performance.



WIDE & STRONG

WIDE è perfettamente idoneo sia per il rivestimento che per la pavimentazione, in ambito residenziale e commerciale. Gli spessori 6 e 7 mm consentono di mantenere un'ottima resistenza al carico di rottura reale.

WIDE is ideal as both a floor and wall covering in residential and commercial projects. The 6 and 7 mm thickness enables it to maintain excellent breaking strength in real situations.



LITE GOES WIDE

Gli spessori 6 e 7 mm consentono e di ridurre il peso per mq con interessanti vantaggi in termini di maneggevolezza e movimentazione.

The 6 and 7 mm thickness results in a reduced weight per square metre, bringing significant advantages in terms of ease of working and handling.



WIDE IS LEVELING

La combinazione fra impasto ad elevata plasticità, spessore e grande dimensione, dona particolare elasticità al prodotto, per ottenere risultati di posa sempre impeccabili.

The combination of a body with high plasticity, thickness and dimensions makes for a highly elastic product that delivers consistently flawless results.



EASY AS WIDE

La formulazione dell'impasto, unita alla compattazione a secco e alla cottura in forni di nuova concezione, genera un gres particolarmente facile da tagliare e lavorare.

The chemical formulation of the body combined with the raw material dry compaction process produces a porcelain slab that is easy to cut and work with.



WIDE MEANS GREEN

L'impasto contiene il 40% minimo di materie prime di qualità recuperate da altri processi produttivi, per questo i prodotti WIDE possono essere accreditati all'interno del sistema internazionale LEED.

As the body contains a minimum of 40% high-quality raw materials recycled from other production processes, WIDE collection products qualify for LEED international certification.

PESO WEIGHT

FLAVIKER 9 mm = 19,5 Kg x mq
FLAVIKER 7 mm = 17,5 Kg x mq
FLAVIKER 6 mm = 15,0 Kg x mq

indicatore di flessibilità flexibility index	deflessione massima sotto carico di 350 N maximum deflection under load of 350 N	lato/length 2400 mm	> 50 mm
		lato/length 2700 mm	> 70 mm
		lato/length 3200 mm	> 100 mm

NEW DIMENSIONS

Uno degli obiettivi del progetto WIDE è quello di fornire un materiale ceramico tecnologicamente avanzato facilmente utilizzabile in contesti anche molto diversi, per dimensione e per destinazione d'uso. WIDE è un vero e proprio programma di formati, tutti rettificati, pensati per coprire a 360° le esigenze legate alla progettazione, a partire dagli spazi residenziali, fino alle grandi opere in ambito pubblico e commerciale.

One of the aims of the WIDE project is to supply a hi-tech ceramic material that is easy to use in very different sizes and applications. WIDE comes in a large selection of sizes, all rectified, ideal for uses ranging from residential through to large-scale works in public and commercial spaces.

EVERYWHERE YOU LIKE

Tenendo conto delle principali qualità del materiale, tra cui la robustezza, la resistenza agli sbalzi termici, oltre allo spessore contenuto e alla facilità di lavorazione, le grandi lastre WIDE ampliano la destinazione d'uso del gres porcellanato. Sempre meno fughe e sempre più spazio alla creatività di progettisti e interior designers, che grazie ai prodotti WIDE possono apprezzare la versatilità di una ceramica senza più confini.

Taking account of the material's key qualities, including strength, thermal shock resistance, low thickness and ease of working, the WIDE large-size slabs extend the fields of use of porcelain. The WIDE collection has fewer joints while giving enormous creative freedom to architects and interior designers, who appreciate the versatility of this ceramic surface without limits.



PAVIMENTI INTERNI
INDOOR FLOORS



RIVESTIMENTI INTERNI
INDOOR WALLS

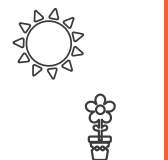

FACCIATE ESTERNE
INCOLLATE E VENTILATE
GLUED AND VENTILATED
EXTERIOR FAÇADES



PAVIMENTI AREE ESTERNE
OUTDOOR FLOORS



PIANI LAVORO CUCINE
KITCHEN COUNTERTOPS



TOP E FINITURE PER AMBIENTI
BAGNO
BATHROOM VANITY TOPS AND
SHELVES



ELEMENTI DI ARREDO E DESIGN
PER INTERNI
INTERIOR FURNISHING AND
DESIGN ELEMENTS

POSA MOVIMENTAZIONE DELLE LASTRE

Durante le verifiche preliminari sul cantiere è opportuno accertare anche la possibilità di movimentare facilmente le lastre all'interno dei locali di posa. Tutti i formati che superano i 100 cm sia di lunghezza che di larghezza devono essere maneggiati da 2 posatori. Per una corretta gestione delle lastre, a partire dalla fase di apertura degli imballi, è necessario avvalersi di dispositivi idonei per la movimentazione. Per la movimentazione manuale e la successiva posa in opera delle lastre WIDE 160x320, al fine di garantire la sicurezza per gli operatori e l'integrità del materiale, è vivamente consigliato l'utilizzo di barre di movimentazione con ventose. 1

Per gli altri formati WIDE inferiori può essere sufficiente l'utilizzo delle sole ventose, anche in relazione allo spessore di 7 mm, che da una maggiore resistenza al prodotto. 2

Gli appositi carrelli di movimentazione sono ideali sul cantiere come "magazzino" per una o più lastre, oltre che per effettuare in totale sicurezza l'operazione di spalmatura dell'adesivo sul retro della lastra. 3

LAYING HANDLING THE SLABS

When performing a preparatory inspection of the site, it is important to check whether the slabs can be handled easily in the installation area. All sizes in excess of 100 cm in either direction must be handled by 2 installers. Always use proper handling equipment to handle the slabs, from unpacking onwards.

When handling and laying WIDE 160x320 cm slabs by hand, use handling bars with suction cups to safeguard both the material and the installers themselves. 1

For smaller WIDE sizes, it may be sufficient to use just suction cups, especially given that the product is 7 mm thick and therefore quite robust. 2

Handling carts are ideally suited for holding slabs on site as well as for applying the adhesive to the back of the slab in total safety. 3



TAGLIO DELLE LASTRE

È opportuno effettuare le operazioni di taglio su una superficie piana, stabile e planare. È consigliato l'utilizzo di guide da taglio professionali con carrello incisore. 4

Una volta rimossa la lastra dall'imballo e posizionata sul piano di lavoro segnare alle due estremità la dimensione da asportare. Posizionare e bloccare la guida di taglio, tenendo conto della distanza del disco di taglio. 5

Incidere le estremità della lastra per circa 5 cm spingendo il carrello di incisione dall'interno verso l'esterno, procedere poi con l'incisione della lastra avendo cura di esercitare una pressione ed un avanzamento del carrello costanti per tutta la lunghezza del taglio.

Traslare la lastra in modo da portare la linea di incisione al di fuori del piano di lavoro di circa 5/10 cm.

Rimuovere la guida di incisione ed iniziare l'operazione di troncatura posizionando l'apposita pinza in corrispondenza della linea incisa; esercitare una pressione leggera e progressiva verso il basso. Quest'operazione risulterà molto semplice in quanto i prodotti Wide sono privi di tensionature e per questo facilmente lavorabili. 6

A questo punto si può procedere con la finitura, che dovrà essere effettuata utilizzando gli appositi tamponi diamantati o in alternativa mediante dischi resinosi abrasivi. 7/8

CUTTING THE SLABS

We recommend cutting the slabs on a flat, stable surface (table). Use professional cutting guides with a cutting slide. 4

Remove the slab from its packaging and place it on the table, then mark the cut at both ends. Locate and lock the cutting guide (make sure to account for the cutting disk offset). 5

Cut the ends of the slab by pushing the slide about 5 cm from the interior to the edge of the slab, then cut the slab in a single smooth, even stroke at constant pressure.

Slide the slab so that the cut line is about 5 to 10 cm beyond the edge of the table.

Remove the cutting guide and shear off the excess material with the clamp located at the cut line; exert gradual, light pressure downwards. This is made particularly easy by the fact that

Wide products have no tensioning and are thus easy to work. 6

You can now finish the slab using diamond pads or abrasive resin disks. 7/8

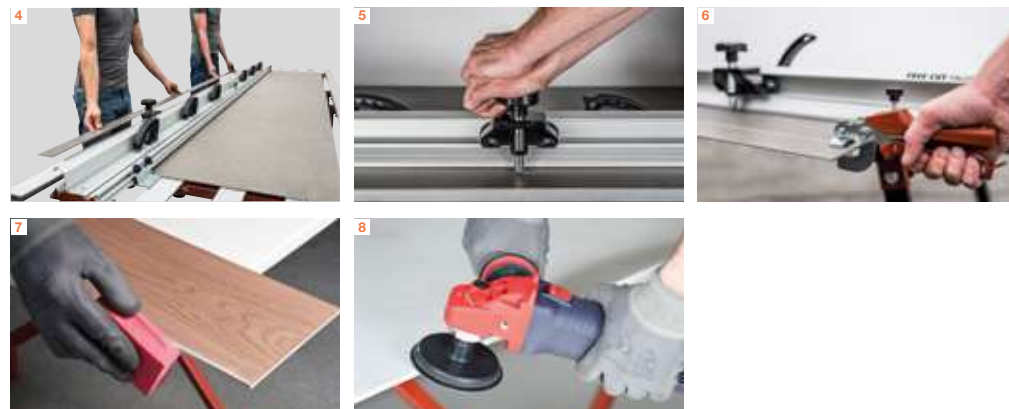

TAGLI A L/SCASSI/ FORI RETTANGOLARI

Una volta tracciata sulla lastra la porzione da asportare è opportuno eseguire, in corrispondenza del punto di congiunzione delle linee, fori di diametro 6/8 mm con foretti diamantati a umido o a secco. 9

Congiungere poi i fori mediante una smerigliatrice angolare equipaggiata con disco diamantato (diametro max. 125 mm) 10

CUTS L CUTS / RECESSED CUTS / RECTANGULAR HOLES

Once you have marked the cut on the slab, drill through the corners of the cut with a dry or wet 6 or 8 mm diamond bit. 9

Now join up the holes with an angle grinder fitted with a diamond disk (maximum dia. 125 mm) 10

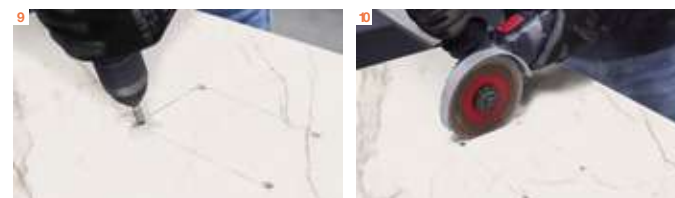

INCOLLAGGIO

Le lastre WIDE richiedono l'utilizzo della tecnica a doppia spalmatura, ovvero il collante dev'essere applicato sia sul fondo di posa che sul retro della lastra. **11** Assicurarsi che la superficie da rivestire sia consistente, planare, priva di polvere e di unti/grassi, così come è bene rimuovere le polveri che possono trovarsi a contatto delle lastre. Stendere il collante sulla superficie da rivestire con spatola a denti inclinati con dente minimo di 8mm con movimenti lineari e mai circolari. Stendere il collante sul retro della lastra con spatola dentata mai inferiore a 5 mm (tenendo conto che la somma delle spatole utilizzate per sottofondo e lastra dev'essere compresa fra i 13 e i 14mm). Per garantire la perfetta posa dei prodotti WIDE occorre far defluire per vibrazione le bolle d'aria che si possono formare fra la lastra e l'adesivo fino a ottenere il "letto pieno" di collante. Per fare ciò è consigliabile avvalersi di un battitore manuale in gomma oppure utilizzare gli appositi dispositivi elettrici batti-piastrelle. **12/13** In relazione al grande formato è consigliato l'utilizzo di distanziali livellanti facendo attenzione che lo strato di adesivo fra lastra e massetto sia almeno di 4 mm, per evitare interruzioni nella massa adesiva. **14/15** La fuga minima consigliata, in relazione alla posizione dei giunti di dilatazione, è di 2 mm. Nel caso di pareti e pavimenti a contatto, da posare entrambi con lastre ceramiche, è indispensabile rispettare questa larghezza minima per garantire un perfetto risultato nel tempo. A rivestimento è possibile realizzare fughe inferiori in base alle opportune verifiche tecniche da effettuarsi sul cantiere. Le fughe dovranno essere riempite per almeno i 2/3 dello spessore con l'apposito sigillante, pertanto occorre prestare attenzione all'eventuale presenza di residui di adesivo all'interno.

GLUING

WIDE slabs must be back-buttered; in other words, the adhesive must be applied both to the substrate and the back of the slab. **11** Make sure the surface is stable, flat, clear of grease and dust, and also wipe off any dust on the back of the slab. Apply the adhesive to the surface with an angled tooth trowel (at least 8 mm), in a linear motion (never in circles). Apply the adhesive to the back of the slab with a toothed trowel (at least 5 mm); note that the sum of the trowel sizes used for the slab and substrate must be 13 - 14 mm. To ensure perfect installation of WIDE products, use vibration to eliminate any bubbles between the slab and the adhesive to obtain a full bonding effect. Use either a rubber mallet or electric tile vibrator for this purpose. **12/13** When installing large sizes, we recommend using levelling spacers; the layer of adhesive between the slab and the substrate must be at least 4 mm thick to ensure continuity. **14/15** The expansion joint between slabs should be at least 2 mm wide. For contact walls and floors, both installed with ceramic slabs, this minimum dimension must be used to ensure a long-lasting result. A smaller joint width is possible when installing walls, following technical inspection on site. The joints must be filled to at least 2/3 of their depth with sealant; take care to remove all adhesive from the joint first.



Indicazioni tecniche sviluppate in collaborazione con Assoposa. Technical instructions developed in collaboration with Assoposa.



LOGISTICA NUOVI SISTEMI DI IMBALLO

L'innovazione della gamma WIDE si esprime anche attraverso la parte logistica del progetto. FLAVIKER Group rivoluziona il sistema di imballaggio delle lastre ed è oggi l'unica azienda che ha portato il sistema a cavalletto impilabile alla dimensione di cm 75x246x149, 75x276x147,5, 75x168x109 e 75x26x200.

Questi i principali vantaggi offerti:

- essendo impilabile permette di ottimizzare gli spazi all'interno dei magazzini.*
- la profondità di 75 cm consente di sfruttare a pieno il volume di carico dei container (3 pallets ne occupano perfettamente la larghezza).
- Il posizionamento verticale del prodotto garantisce una maggiore protezione delle lastre durante le fasi di trasporto.
- facilita le operazioni sul cantiere in quanto le lastre si trovano già posizionate in verticale, il materiale è facilmente ispezionabile e removibile per l'installazione.
- le dimensioni complessive del cavalletto consentono maggiori spazi di manovra all'interno dei locali di posa rispetto alle casse tradizionali e agevolano il sollevamento del materiale mediante mezzi meccanici (gru-montacarichi).
- è caratterizzato da un sistema di regettatura che consente di liberare anche 1 solo collo alla volta, senza compromettere la stabilità del materiale che rimane sul pallet, evitando così il rischio di rotture. Le lastre dovranno essere liberate rispettando la sequenza opposta rispetto a quella con cui sono state confezionate, quindi iniziando dall'ultimo collo regettato.

LOGISTICS NEW PACKAGING SYSTEMS

Innovation in the WIDE range is also reflected in the project's logistics. FLAVIKER Group has revolutionised the packaging of ceramic slabs and is the only company to have expanded the stacking rack pallet system to the 75x246x149, 75x276x147,5, 75x168x109 and 75x26x200 cm size.

This has the following advantages:

- stacking optimises the use of space in warehouses.*
- the 75 cm depth enables full use of container load space (3 pallets fit perfectly side by side). The vertical positioning of the product better protects the slabs during shipping.
- it facilitates work on site, since the slabs are already positioned vertically, making the material easy to inspect and remove for installation.
- the overall size of the rack pallet provides greater space for manoeuvring in the installation area in comparison with conventional crates, and also makes it easier to lift the slabs mechanically (with a crane or lift).
- the rack pallet system employs strapping which allows the user to remove a single package at a time without affecting the stability of the other packages on the pallet, thus minimising the risk of breakage. The slabs must be released from the packaging by reversing the packaging sequence, i.e. starting with the last package to have been strapped on.

CAVALLETTO impilabile Stackable Rack pallet

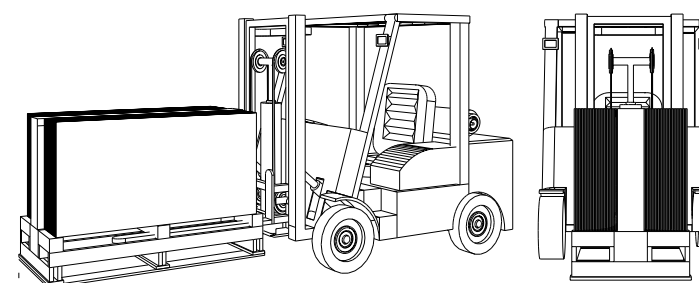
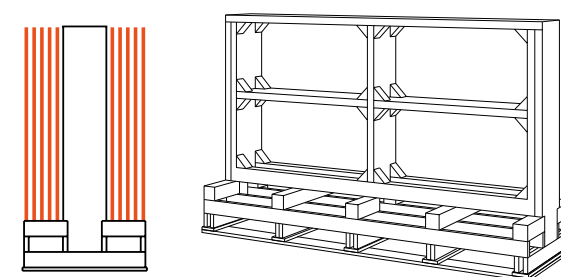

Modalità di trasporto consigliata per ottenere la massima visibilità.

Recommended transport system for maximum visibility.

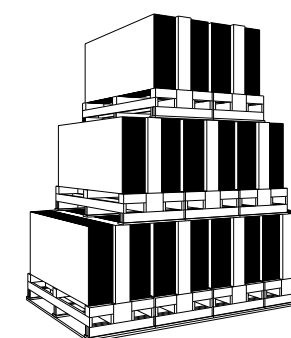

*Esempio di sovrapposizione del rack pallet con il formato 80x160.

*Example of stacked rack pallets with the 80x160 cm size.

Per una corretta movimentazione di casse, cavalletti e pallet si raccomanda l'utilizzo di un carrello elevatore a forche con lunghezza di almeno 2,5 mt e con il posizionamento nella massima larghezza.

Top handle crates, rack pallets and pallets properly, use a lift truck with at least 2.5 m forks at their maximum width.

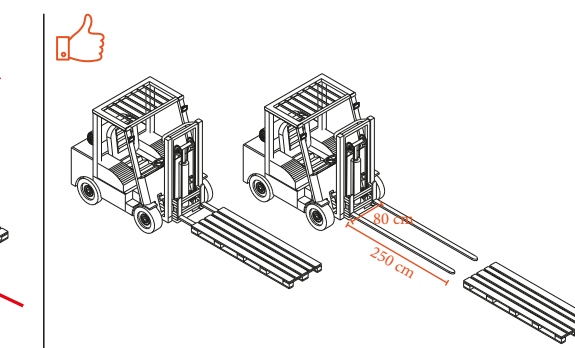
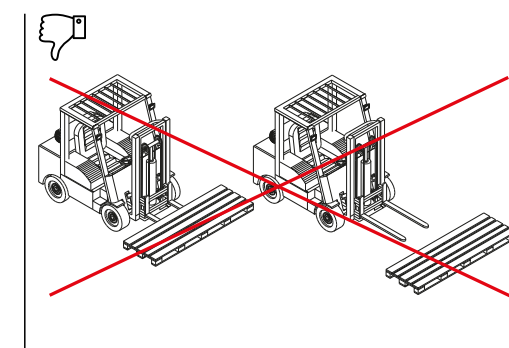

WIDE

SUPERSIZE SLABS

CASSA - Crate

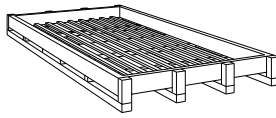

Ingombro Size
174x345x27,5
(160x320 RETT/LUX*)
€ 130,00

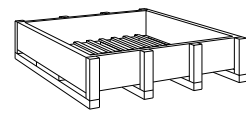

Ingombro Size
174x185x42,5
(160x160 RETT/LUX*)
€ 90,00

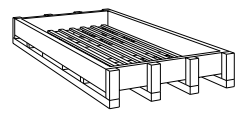

Ingombro Size
134x265x32
(120x240 LUX*)
€ 100,00

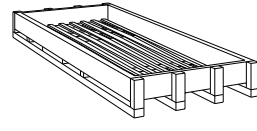

Ingombro Size
134x295x32
(120x270 LUX*)
€ 100,00

CAVALLETTO - Rack pallet

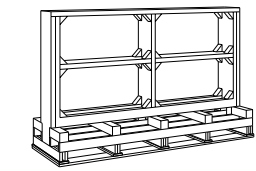

Ingombro Size
75x246x149
(120x240 RETT)
€ 120,00

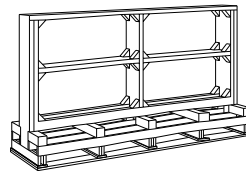

Ingombro Size
75x276x147,5
(120x270 RETT)
€ 120,00

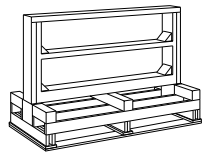

Ingombro Size
75x168x109
(80x160 RETT)
€ 50,00

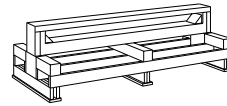

Ingombro Size
75x26x200
(26x200 RETT)
€ 50,00

CAVALLETTO PER CONTAINERS - Rack pallet for containers

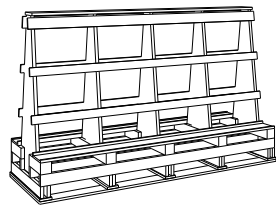

Ingombro Size
75x330x201
(160x320 RETT/LUX*)
€ 235,00

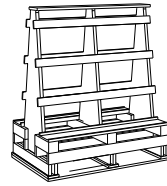

Ingombro Size
75x170x201
(160x160 RETT/LUX*)
€ 170,00

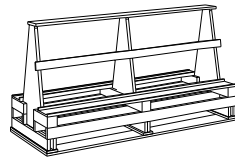

Ingombro Size
75x280x161
(120x270 RETT/LUX*)
€ 210,00

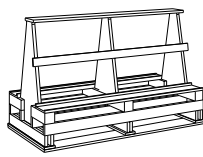

Ingombro Size
75x250x161
(120x240 RETT/LUX*)
€ 190,00



Ingombro Size
75x130x149
(120x120 RETT./LUX*)
€ 190,00

PALLET CON SPONDE - Pallet with sides

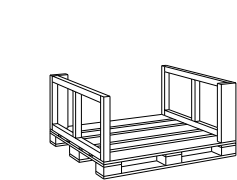

Ingombro Size
122x143x70
(120x120 LUX*)

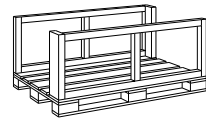

Ingombro Size
99x162x70
(80x160 LUX*)



Ingombro Size
80x130x60
(60x120 30x120 80x80)
VERTICALE/VERTICAL

PALLET PER ORDINI AL VENDUTO - Picking order pallet

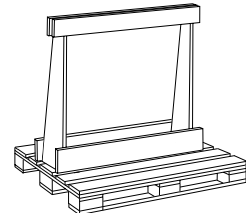

Ingombro Size
80x130x120
(120x120)
VERTICALE/VERTICAL
€ 25,00

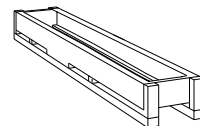

Ingombro Size
35x225x32
(26x200 RETT)

IMBALLI 12 MM - PACKAGING 12 MM

CASSA - Crate

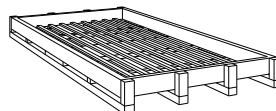

Ingombro Size
174x345x27,5
(163,5x323)
€ 130,00

CAVALLETTO CONTAINER LEGNO A - FRAME

Container Rack pallet wood A - frame

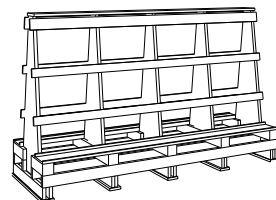

Ingombro Size
75x330x201
(163,5x323)
€ 235,00

CAVALLETTO CONTAINER METALLO A - FRAME

Container Rack pallet metal A - frame

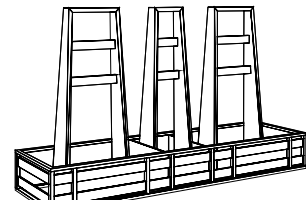

Ingombro Size
75x330x201
(163,5x323)
€ 400,00

IMBALLI PACKAGING

	F.to nominale (cm) Nominal size (cm)	F.to reale (mm) Work size (mm)	Spessore Thickness	Tipologia imballo Type of packing	Lastre/ Imballo Slabs/ Packing	Pz/Scatola Pcs/Box	Mq/Scatola SqM/Box	Kg/Scatola Kg/Box	Scatole/ Imballo Box/Packing	Mq totali SqM total	Kg/Imballo Kg/Packing	Kg totali Kg total	Prezzo imballo Packing Price
	163,5x323 nat	1635x3230	12mm	Cassa Crate	10	-	-	-	-	51,20	139	1.660	€ 130,00
	163,5x323 lux*	1635x3230	12mm	Cassa Crate	9	-	-	-	-	46,08	139	1.508	€ 130,00
	163,5x323 nat/lux*	1635x3230	12mm	Cavalletto container legno A - frame Container Rack pallet wood A - frame	22	-	-	-	-	112,64	180	3.524	€ 235,00
	163,5x323 nat/lux*	1635x3230	12mm	Cavalletto container metallo A - frame Container Rack pallet metal A - frame	22	-	-	-	-	112,64	180	3.524	€ 400,00
	160x320 rett/lux*	1596,5x3195	6 mm	Cassa Crate	14	-	-	-	-	71,68	139	1.214	€ 130,00
				Cavalletto container Container Rack pallet	36	-	-	-	-	184,32	180	2.945	€ 235,00
	120x270 rett	1194x2700	6 mm	Cassa Crate	18	-	-	-	-	58,32	112	987	€ 115,00
				Cavalletto Rack pallet	36	-	-	-	-	116,64	115	1.865	€ 135,00
				Cavalletto container Container rack pallet	36	-	-	-	-	116,64	130	1.880	€ 210,00
	120x240 rett/lux*	1194x2390	6 mm	Cavalletto Rack pallet	40	-	-	-	-	115,20	100	2.116	€ 120,00
				Cassa Crate	20	-	-	-	-	57,60	100	1.108	€ 100,00
				Cavalletto container Container Rack pallet	40	-	-	-	-	115,20	115	2.131	€ 190,00
	160x160 rett/lux*	1596,5x1596,5	6 mm	Cassa (160x160) Crate	28	-	-	-	-	71,68	75	1.150	€ 90,00
				Cassa (160x320) Crate	28	-	-	-	-	71,68	139	1.214	€ 130,00
				Cavalletto container Container Rack pallet	36	-	-	-	-	92,16	95	1.477	€ 170,00
	80x160 rett/lux*	797,25x1596,5	9 mm	Cavalletto Rack pallet	44	2	2,56	50,00	22	56,32	70	1.170	€ 50,00
				Pallet con sponde Pallet with sides	44	2	2,56	50,00	22	56,32	40	1.140	-
	120x120 rett/lux*	1194x1194	7 mm	Pallet con sponde Pallet with sides	44	2	2,88	50,40	22	63,36	40	1.149	-
	120x120 rett/lapp	1194x1194	9 mm	Pallet con sponde Pallet with sides	36	2	2,88	56,16	18	51,84	40	1.051	-
	26x200 rett	264,4x2000	7 mm	Cavalletto Rack pallet	80	5	2,60	45,50	16	41,60	50	778	-

12 MM 163,5X323

FLAVIKER garantisce una superficie utile pari a 1635x3230 mm, la fatturazione invece è calcolata sulla base del formato 1600x3200 mm. FLAVIKER guarantees a useful surface area of 1635x3230 mm whereas billing is calculated on the basis of a 1600x3200 mm size.

Su richiesta, le lastre in 12 mm di FLAVIKER possono essere rinforzate strutturalmente con una stuoia in fibra di vetro applicata sul retro con apposito collante. L'applicazione della stuoia prevede una maggiorazione di € 9,00 al mq sul prezzo netto della lastra. On request, the 12 mm slabs from FLAVIKER can be reinforced with fiberglass matting applied to the rear surface using a special adhesive. The fiberglass matting application involves a 9,00 € per sqm increase on the slab's net price.

AUTO-LEVELING™

Facile installazione - Easy laying

CARATTERISTICHE

Auto-Leveling garantisce la massima facilità di posa ai listoni di grande formato. La tecnologia si basa sull'impiego di impasti a base di materie prime per loro natura altamente stabili e resistenti, ma al tempo stesso ad elevata plasticità, che conferiscono a questa tipologia di prodotti qualità uniche. Il materiale ottenuto, caratterizzato da un minimo grado di convessità, aderisce perfettamente al massetto. Una volta posata, la piastrella si auto-livella, mantenendo una perfetta planarità. La tecnologia Auto-Leveling si applica alle lastre ceramiche nei formati 20x170 e 40x170 cm (sp9mm).

CHARACTERISTICS

Auto-Leveling guarantees the maximum ease of installation for large-format planks. The technology uses raw materials that combine stability and strength with high plasticity, giving unique qualities to this type of product. The resultant tiles have a small degree of convexity and bond perfectly to the screed. Once installed, the tiles self-level and maintain perfect flatness. Auto-Leveling technology is used for ceramic tiles in sizes 20x170 cm and 40x170 cm (thickness 9mm).



Indicatore di flessibilità
flexibility index

Lastre prodotte con materie prime ad elevata plasticità, resistenti ma flessibili.
Ceramic slabs manufactured with highly plastic raw materials, strong and flexible at the same time.



Appoggiate su qualsiasi superficie, anche non perfettamente planare, le lastre si auto-livellano.
Laid on the screed they self-level, even if the surface is not perfectly flat.



Il prodotto auto-leveling agevola la posa tradizionale, si monta senza distanziali livellanti, seguendo qualsiasi schema di posa.
Auto-leveling tiles help the traditional fixing, every installation pattern can be achieved, without leveling spacers.

indicatore di flessibilità flexibility index	deflessione massima sotto carico di 350 N maximum deflection under load of 350 N	lato/length 1200 mm	> 20 mm
		lato/length 1700 mm	> 30 mm

INSTA-TILE

DRY FIXING

Le lastre Auto-Leveling nel formato 20x170 possono essere montate seguendo il sistema Insta-Tile, un nuovo metodo di posa a secco che consiste nel fissaggio del materiale direttamente sul pavimento preesistente, senza alcuna opera di demolizione. Dopo aver steso un tappetino in sughero o polietilene dello spessore di circa 2 mm, si consiglia di posizionare una serie di distanziali di 5 mm lungo tutte le pareti interessate per poi proseguire con la posa delle piastrelle, a giunto unito, praticando tutti i tagli necessari fino a coprire completamente il vecchio pavimento. Per contenere le dilatazioni si consiglia di applicare qualche goccia di silicone lungo il perimetro, per poi rimuovere i distanziali e procedere con l'inserimento del profilo o del battiscopa. Il nuovo pavimento, la cui superficie risulterà perfettamente planare anche senza l'utilizzo di colle e sigillanti e potrà facilmente essere rimosso e recuperato in qualsiasi momento.

Our 20x170 auto-leveling slabs can be laid using the Insta-Tile system, which is a new dry-fixing method that consists in laying the tiles directly on top of the existing floor, without any scrapping or removal work. After laying an approximately 2 mm thick cork or polyethylene underlayer, we recommend you fit a series of 5 mm spacers along all the perimeter before laying the tiles. The tiles should be laid with a closed joint and cut where necessary to completely cover the old floor. To limit expansion, it is recommended to apply a few drops of silicon around the outer edge, then remove the spacers and fit the edge trim or the skirting. The new floor, whose surface should be perfectly flat even without the use of glues or sealants, can be removed and re-used at any time.

Installazione prevista esclusivamente con prodotti AUTO-LEVELING nel formato 20x170.



Installazione adatta unicamente ad ambienti INDOOR.

This system can be used for INDOORS installation only.



Si sconsiglia l'utilizzo di INSTA-TILE negli ambienti maggiormente umidi o sporchevoli, come bagno e cucina.

INSTA-TILE is not recommended in wet or easily dirtied areas, such as bathrooms and kitchens.



Il metodo INSTA-TILE permette di stendere le lastre senza alcuna fuga.

AUTO-LEVELING tiles can be installed with close joints.

INSTA-TILE

DRY FIXING



L'applicazione può avvenire in diverse situazioni:

- su massetto in cemento
 - su massetto in cemento con impianto di riscaldamento
 - su pavimento preesistente in ceramica, legno o linoleum
 - su pavimento preesistente con impianto di riscaldamento
- In tutti questi casi dev'essere utilizzato un materassino in sughero o in polietilene su cui stendere le lastre. È possibile direttamente su moquette di basso spessore senza l'ausilio del materassino.

It can be laid in different solutions:

- on top of cement screeds,
 - on top of cement screeds with heating systems
 - on top of existing ceramic, wooden or linoleum floorings
 - on top of existing floorings with heating systems
- In all these cases, a cork or polyethylene underflooring must be used.

The planks can also be laid directly on top of short-pile carpet, without needing the underflooring.



Il pavimento INSTA-TILE si può pulire con normali detersivi, utilizzando regolarmente il panno bagnato ed i vari sistemi mop. Nel caso di versamento importante di liquidi, sollevare le lastre ceramiche nella zona interessata aiutandosi con una ventosa, asciugare o sostituire la porzione del materassino sottostante e ri-posizionare le piastrelle.

Insta-Tile flooring can be cleaned with normal cleaning detergents, using a wet cloth or a traditional mop. In the event of major spills, lift up the ceramic tiles in the affected area using a suction cup, dry or replace the area of underflooring below and refit the tiles.



Si sconsiglia l'utilizzo di INSTA-TILE in presenza di animali domestici.

We do not recommend use of the INSTA-TILE system in homes with pets.

ACCESSORI PER POSA A SECCO INSTA-TILE ACCESSORY FOR DRY FIXING INSTA-TILE

TAPPETINI PER SOTTOPAVIMENTO IN ROTOLO

Codice Code	Misura Size	Prezzo Price	imb.	confezione packaging
TPPPOL1	TAPPETO POLIETILENE ANTRACITE 2,5 mm rotolo dimensione 1,50x25,00 m	11,50 / mq	1	rotolo da 37,5 mq
TPPSUG1	TAPPETO SUGHERO NATURALE 2 mm rotolo dimensione 1,00x30,00 m	10,50 / mq	1	rotolo da 30 mq



Tappeto polietilene antracite 2,5 mm



Tappeto sughero naturale 2 mm

ELEMENTI DI FINITURA

Codice Code	Misura Size	Prezzo Price	imb.	confezione packaging
RACALL1	RACCORDO ALLUMINIO ANODIZZ. PAVIMENTO/PARETE barra di lunghezza 1,20 m - h = 4,5 mm	14,70 / pz	5	scatola da 5 pz
TERALL1	TERMINALE di DISLIVELLO ALLUMINIO ANODIZZ. barra di lunghezza 1,20 m - h = 11 mm	17,30 / pz	5	scatola da 5 pz
PRFALL1	PROFILO di DISLIVELLO ALLUMINIO ANODIZZ. barra di lunghezza 1,20 m - h = 10 mm	18,00 / pz	5	scatola da 5 pz

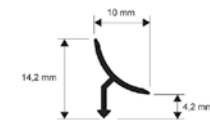

Raccordo pavimento/parete



Terminale di dislivello



Profilo di dislivello

Per maggiori informazioni sulla tecnologia Auto-leveling e sul sistema di posa Insta-Tile puoi effettuare il download del filmato ufficiale di presentazione su www.flaviker.it
For further information on Auto-leveling technology and the Insta-Tile installation system, download the official presentation video on the website www.flaviker.it

Il gradone Jolly **JO** di **OLMOlab** è un pre-assemblato costituito da due lastre in gres porcellanato: la pedata, di dimensione 120x40 cm e l'alzata di dimensione 120x20 cm, tenute insieme perpendicolarmente lungo lo spigolo da una resina ad alta resistenza.

Le dimensioni di questo elemento pre-assemblato sono state studiate per permettere ai posatori, una volta calcolate le reali dimensioni della scala, di ricavarne tutte le parti che compongono il gradino definitivo (un fascione, da cui si possono estrapolare gli elementi laterali e il battiscopa e l'elemento gradino già assemblato).

JO, è caratterizzato da una lavorazione "JOLLY" in tutti i lati, in modo da facilitare il lavoro dei posatori nella fase di assemblaggio (vedi puntini neri nel disegno in basso).

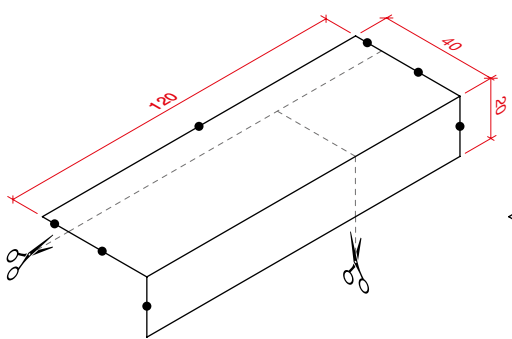

FASCIONE
Dall'elemento "fascione" si possono ricavare i laterali L1 e L2 e il battiscopa B1 e B2.

STRIP
The strip can be cut into the side pieces L1 and L2 and the skirting elements B1 and B2.

GRADINO
L'elemento "gradino", una volta rifilata la lastra verticale, riportandola alla giusta dimensione dell'alzata, è pronto per essere posato, presentando i 2 lati "jollati" da assemblare con i "laterali" L1 ed L2. Anche gli elementi B1 e B2 sono pronti per essere posizionati.

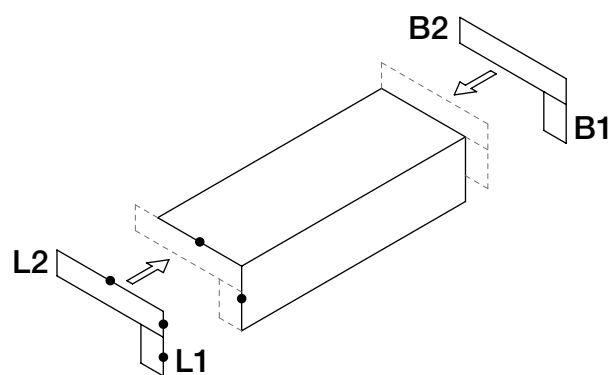

The Jolly **JO** step from **OLMOlab** is a pre-assembled unit consisting of two porcelain slabs (a 120x40 cm tread and a 120x20 cm riser) held together at right-angles by a high-strength resin.

The dimensions of this pre-assembled unit are specially chosen to enable tile layers to cut out all the components of the finished step (a strip, from which the side pieces and skirting can be cut, and the pre-assembled step itself) according to the real dimensions of the stairs.

JO comes with mitred edges on all sides to facilitate the tile layer's work during assembly (see black dots in drawing below).

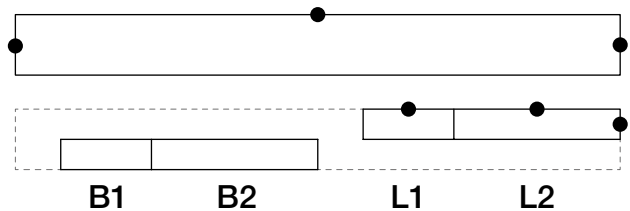
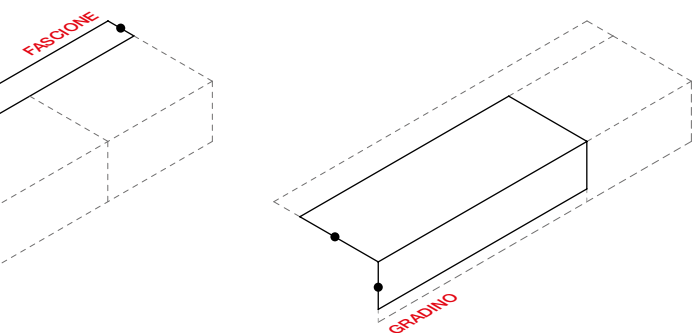

STEP
After trimming the vertical section to the correct size for the riser, the step element is ready for installation. It comes with 2 mitred edges to ensure a perfect joint with the side pieces L1 and L2. The skirting elements B1 and B2 are also ready to be installed.

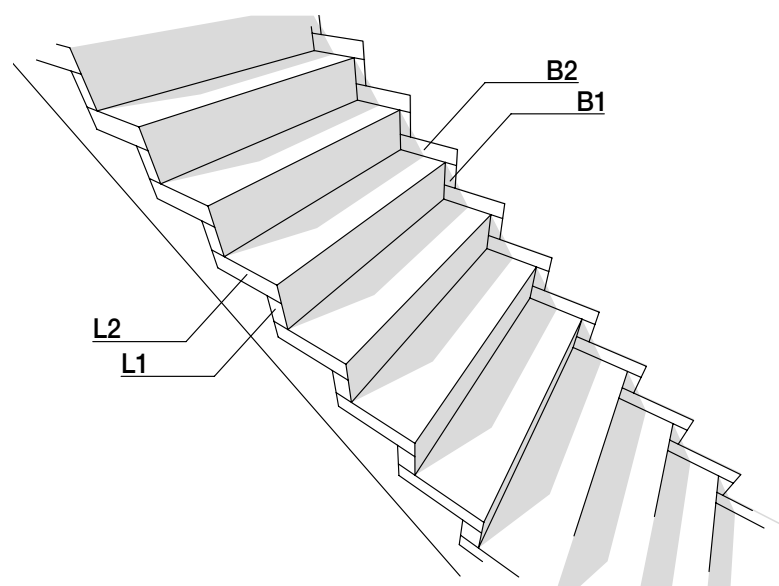

CARATTERISTICHE

Wall&Porcelain nasce come evoluzione della ceramica da rivestimento tradizionale e allo stesso tempo riprende qualità tipiche del gres porcellanato, pur senza averne i limiti. È possibile produrre in W&P lastre ceramiche rettificate di grande formato, fino a 60x120 cm (tecnicamente non realizzabili in bicottura o monoporosa), leggere, maneggevoli, sottili (7 mm) e perfettamente planari, più facili da posare, lavorare e tagliare rispetto al gres, pratiche come i rivestimenti classici, ma inalterabili nel tempo e senza difetti post posa. W&P, oltre ad unire qualità tecniche di prodotto e praticità d'uso, incontra il design e permette di realizzare proposte sempre nuove e diversificate, in linea con le ultime tendenze e facilmente coordinabili con i pavimenti in gamma. Ispirazioni che spaziano dai wallpaper, fino alle superfici strutturate e 3D, per utilizzi molto diversi, ideali per la progettazione di tutti gli ambienti interni.

CHARACTERISTICS

Wall&Porcelain combines the qualities of conventional ceramic wall tiles with those of porcelain tiles while avoiding their respective limitations. W&P can be used to produce large-size rectified ceramic panels up to 60x120 cm in size (not technically possible for double-fired or monoporosa tiles). These panels are lightweight, thin (7 mm), easy to handle and perfectly flat. They are easier to install, work with and cut than porcelain and are just as practical as conventional wall tiles while also being supremely durable and free of post-installation defects. But along with technical qualities and practicality of use, W&P also attains a high level of design and can create ever new and diversified offerings that follow the latest trends and coordinate easily with the floor tiles in the range. The tiles draw inspiration from a range of sources including wallpapers and textured and 3D surfaces and are suitable for all interior applications.

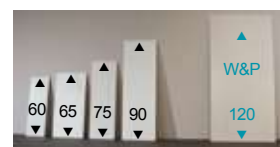

GRANDE FORMATO, BASSO SPESSORE

La tecnologia Wall&Porcelain, a differenza della monoporosa tradizionale, permette di produrre lastre ceramiche rettificate monocalibro di grandi dimensioni e dallo spessore ridotto.

BIG SIZE, THIN THICKNESS

The technology Wall&Porcelain, unlike traditional mono-porous, allow to produce ceramic slabs rectified mono-caliber in big sizes and reduced thickness.



ELASTICITÀ

Wall&Porcelain garantisce una maggiore aderenza alle superfici mantenendo una perfetta planarità.

ELASTICITY

Wall&Porcelain ensures greater adherence to surfaces while maintaining a perfect flatness.



RESISTENZA

Le superfici risultano resistenti, come quelle del gres.

RESISTANCE

The surfaces are resistant, like porcelain stoneware ones.



LEGGEREZZA

Il peso ridotto, rispetto al gres tradizionale, rende il prodotto più maneggevole.

LIGHTWEIGHT

The light weight compared to traditional porcelain stoneware makes this product easy to handle.



PRATICITÀ

Wall&Porcelain è un materiale incredibilmente facile da tagliare e da lavorare.

PRACTICALITY

Wall&Porcelain is a material incredibly easy to cut and process.



AFFIDABILITÀ

È immune dal problema delle microfessurazioni superficiali che possono presentarsi nel post posa (cavillo tardivo).

RELIABILITY

It is immune to the problem of superficial micro-cracks that may occur after the installation (after-laying crazing).

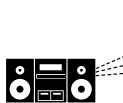

COMFORT

Offre un isolamento termico ed acustico superiore rispetto a quello del gres.

COMFORT

It offers greater thermal and acoustic insulation compared to porcelain stoneware.



INTELLIGENTE

È realizzato con lo speciale impasto ECO-BODY, contenente il 40% di materie prime recuperate da altre lavorazioni industriali.

INTELLIGENCE

It is produced with the special ECO-BODY mix hat contains 40% of raw material recovered from other industrial processes.



ECO-SOSTENIBILE

È rettificato a secco, con un minor consumo di energia e un totale recupero degli scarti di lavorazione.

ECO-SUSTAINABILITY

A dry straight edge cutting system is used with reduced energy consumption and total recovery of processing waste.

INDICATORE DI FLESSIBILITÀ FLEXIBILITY INDEX	DEFLESSIONE MASSIMA SOTTO CARICO DI 200 N RELATIVAMENTE AL LATO 1200 mm MAXIMUM DEFLECTION UNDER LOAD OF 200 N, RELATED TO 1200 mm LENGTH	> 20 mm
-------------------------------------------------	----------------------------------------------------------------------------------------------------------------------------------------------	---------

CONSIGLI PER LA POSA E LA PULIZIA / INSTALLATION AND CLEANING ADVICE

AVVERTENZE GENERALI

Indipendentemente dal tipo di prodotto e formato scelto, prima di procedere con la posa è opportuno fare una verifica sul cantiere per valutare le condizioni dei sottofondi. La posa richiede le migliori condizioni del sottofondo. Che dovrà sempre essere:

-asciutto e stagionato
-planare e privo di fessurazioni
-pulito, libero da polvere detriti o grumi di cemento
-compatto e resistente

La perfetta riuscita di un pavimento o di un rivestimento è il frutto della combinazione di molteplici fattori; per ottenere il migliore effetto estetico nella posa è opportuno ricordare che i prodotti FLAVIKER Group prevedono un numero variabile di pattern grafici, la cui successione all’interno delle scatole avviene in modo del tutto casuale.

POSA DEI PRODOTTI RETTIFICATI

Per raggiungere un effetto ottimale FLAVIKER suggerisce di mantenere almeno 1 o 2 mm di fuga per una posa mono-formato e 2 mm per combinare formati misti nelle pose modulari suggerite dai cataloghi.

POSA DEI PRODOTTI NON RETTIFICATI

L'alto grado di greificazione delle piastrelle FLAVIKER comporta modeste tolleranze di calibro, pertanto nella posa dei prodotti a bordo naturale è consigliabile lasciare una fuga di almeno 3 mm fra le piastrelle.

OPERAZIONI PRELIMINARI

Una volta scelto il materiale da posare, coerentemente con i requisiti tecnici, lo stile e la destinazione d’uso degli ambienti, è bene seguire alcune raccomandazioni prima di procedere con l’installazione.:

-stendere a terra almeno 3mq di prodotto per controllare l’effetto d’insieme, avendo cura di verificarne accuratamente calibro, tonalità e scelta.

-Specie nel caso di prodotti con elevata variabilità grafica, è bene posare il materiale attingendo da più scatole, le variazioni grafiche e cromatiche del prodotto sono una caratteristica qualificante che l’abilità del posatore può valorizzare, al contrario un prodotto posato senza tenerne conto può risultare esteticamente poco gradevole.

-È opportuno evitare di segnare la parte superiore delle piastrelle con matite o pennarelli e dedicare particolare attenzione ai prodotti lucidi, patinati o lappati che dovranno essere coperti durante i lavori di cantiere.

-Attendere 48/72 ore prima di sottoporre il pavimento al normale transito.

La posa senza fuga, soprattutto nei grandi formati è fortemente sconsigliata dai maggiori produttori di collante per i seguenti motivi:
Difficoltà di assorbimento di eventuali movimenti strutturali in assenza di elementi comprimibili
Diverso comportamento dilatometrico fra piastrelle e massetto, in presenza di elevate escursioni termiche
Difficoltà di realizzazione di una duratura ed efficace stuccatura
FLAVIKER sconsiglia assolutamente pose senza fuga, per le quali si declina ogni responsabilità.

Durante le operazioni di posa, nel caso venga scelto uno schema sfalsato, evitare di far coincidere i vertici di una piastrella con la metà delle altre a fianco. Soltanto i prodotti AUTO-LEVELING si prestano ad essere posati seguendo liberamente ogni schema di posa.

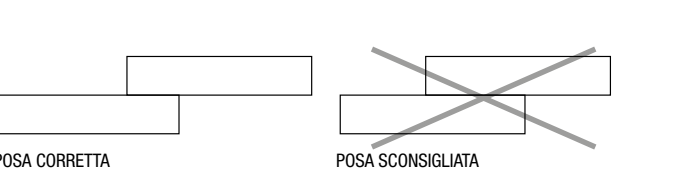

STUCCATURA

1) Qualora non si utilizzasse la boiaccia composta da cemento e sabbia, si consiglia di utilizzare colori di stucco su tono (possibilmente non utilizzare su materiali di colore chiaro stucchi di colore scuro, tipo nero, blu, rosso) e di verificare la compatibilità dei riempitivi per fughe con il prodotto ceramico.
2) Riempire le fughe con gli stucchi solo quando il pavimento è calpestabile, togliendo preventivamente dalle fughe ogni tipo di residuo.
3) Eseguire la stuccatura a “regola d’arte”, seguendo le indicazioni del progettista, del responsabile di cantiere e del capitolato di posa.
4) Stuccare piccole superfici per volta (4/5 mq) e asportare le quantità eccedenti con spugne o stracci umidi (di sola acqua pulita).
5) Stucchi cementizi non additivati: seguire attentamente le indicazioni dei fabbricanti, a fine giornata pulire i residui di posa con spugna appena bagnata.
6) Stucchi epossidici o additivati (con lattici, ecc.): seguire attentamente le indicazioni dei fabbricanti, perché il loro rapido indurimento può richiedere pulizie molto laboriose, specialmente se la superficie delle piastrelle è antiscivolo, ruvida o strutturata.

GENERAL WARNINGS

Regardless of the chosenproduct type or size, an on-site inspection should be carried out prior to installation to assess the conditions of the substrates.Perfect substrate conditions are essential for a successful installation.Substrates must be:

-dry and properly cured
-flat and free of cracks
-clean and free of dust, debris or lumps of cement
-compact and strong

The success of a floor or wall tile installation is the result of a combination of multiple factors; to achieve the best possible aesthetic effect in installation, remember that FLAVIKER Group products come in a variable number of graphic patterns packed in boxes in a completely random sequence.

INSTALLATION OF RECTIFIED-EDGED TILES

For optimal results, FLAVIKER recommends allowing a joint of at least 1 or 2 mm when laying same-sized tiles and 2 mm for different-sized tiles laid using the modular systems described in the catalogues.

INSTALLATION OF NON-RECTIFIED TILES

The high degree of vitrification of FLAVIKER tiles means dimensional tolerances are low. Therefore, when laying tiles with natural press-formed edges, at least a 3mm joint should be allowed between each tile.

PRELIMINARY OPERATIONS

It is advisable to follow some recommendations before proceeding with the installation of the selected tiling material, which should be carried out in compliance with the technical requirements, style and intended application;

-Place some tiles (at least 3 m²) over the flooring surface to check the final effect, making sure you have the right tile size, shade, and quality class.

-In the case of products whose graphics tend to differ considerably from one tile to the next, it is advisable to take the tiles from different boxes and mix them. The graphic and colour variations of the tiles are an important feature which can be enhanced by a skilled tile layer. Overlooking such features, on the contrary, may lead to poor aesthetic results.

-Avoid marking the front of the tiles with pencils or markers. Be particularly careful with glossy, matt or lapped tiles, which should be kept covered during building work.

-Wait 48/72 hours before walking over the newly laid tiles.

Jointless tile installation, particularly in the case of large-size tiles, is strongly advised against by most adhesive manufacturers for the following reasons:
Any structural adjustments may not be absorbed due to the lack of compressible material.
Wide temperature ranges may cause expansion effects between the tile and screed.
Effective, durable grout joints may be difficult to achieve.
FLAVIKER strongly advises against jointless tile installation and cannot be held liable for any damage deriving therefrom.

When laying tiles in a staggered pattern, make sure there are no tiles positioned with the corner coinciding with the centre of the adjacent tiles. Only AUTO-LEVELING products are suitable for all installation patterns.

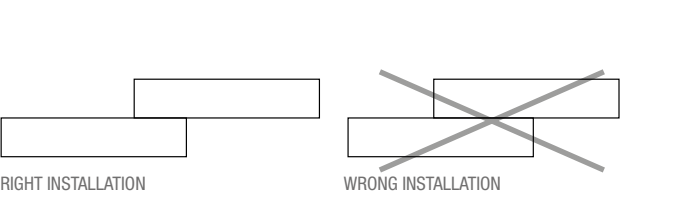

GROUTING

1)Should a grout made of cement and sand not be used, it is recommended to use shade-on-shade grouts (do not use dark grouts, such as black, blue or red, on bright materials) and to verify the compatibility of the grouts with the ceramic tile.
2)Fill the grout lines with the grout only when the floor has sufficiently set to be ready to tread on, removing any residue from the gout lines.
3)Carry out a state-of-the-art grouting following the layer and technician’s instructions and the technical specifications.
4)Grout small areas of the surface at a time (4m≤ to 5m≤) and remove excess grout with a sponge or a wet cloth (with clean water).
5)Non-added cement grouts: follow the manufacturer’s instructions carefully and at the end of the working day clean the surface with a slightly damp sponge.
6)Epoxy grouts or added grouts (with latex, etc): follow the manufacturer’s instructions to the letter as rapid hardening can lead to difficult cleaning operations, especially in case of anti-slip, rough or textured tiles.

LAVAGGIO DOPO LA POSA

Il lavaggio dopo la posa è una fase di fondamentale importanza per tutti gli interventi successivi e per la manutenzione. La pulizia di fine cantiere fatta con prodotti a base acida tamponati, quali ad esempio Deterdek di Fila o Cement Remover di Faber etc. va eseguita una sola volta e presenta l’ulteriore vantaggio di conferire uniformità cromatica alla superficie. Con il lavaggio acido dopo la posa si eliminano i residui di posa e il normale sporco di cantiere come: malta, colla, pittura, sporco da cantiere di varia natura. E’ bene sapere che oltre il 90% delle contestazioni in cantiere è dovuto ad un cattivo, o addirittura inesistente, lavaggio con detergente acido dopo posa. Per evitare che un prodotto a base acida usato per la prima pulizia vada ad intaccare il riempimento a base cementizia delle fughe, è necessario, prima dell’operazione di pulizia, bagnare il pavimento affinché le fughe vengano impregnate e pertanto protette dall’azione corrosiva dell’acido stesso.

È opportuno:

- Togliere con appositi detersivi a base alcalina sostanze grasse o simili
- Procedere al lavaggio dopo la posa
- Risciacquare abbondantemente il pavimento, raccogliendo l’acqua residua.
- La pulizia si esegue dopo 4-5 giorni dalla stuccatura (lo stucco deve indurire) e non oltre i 10 giorni, oltre questi tempi la pulizia può diventare molto più laboriosa; attenersi scrupolosamente ai consigli riportati dal produttore di detersivi.

Fare sempre test preventivi (su una piastrella non posata), in particolare per prodotti lappati o levigati.

POSA E PULIZIA DI DECORI CON MATERIALI NATURALI

3x30 CM. FASCIA SLATE ROSSO / SLATE NERO

I tozzetti che compongono il decoro sono ricavati, uno ad uno, dal taglio di lastre di ardesia di vari formati, ma sempre di spessore 10 mm. Trattandosi di “pietra naturale” determinate irregolarità di superficie e di spessore fanno parte del prodotto e ne sono caratteristica insopprimibile. La posa in opera va fatta utilizzando le normali colle ceramiche da mosaico, usando la tecnica della doppia spalmatura. Per la stuccatura usare esclusivamente stucchi epossidici, avendo cura di rimuovere l’eccedenza prima della completa essiccazione. La manutenzione e la pulizia vanno fatte utilizzando i normali prodotti per il marmo / pietre naturali reperibili sul mercato, evitando i prodotti abrasivi.

2x30 CM. OAK GREY / WALNUT BEIGE

Componente legno: essenza di legno naturale lavorato artigianalmente a singolo pezzo e verniciato in modo da renderlo praticamente inassorbente. Componente supporto: il legno è supportato da WPC in lastre. Un materiale perfettamente stabile, ignifugo, inattaccabile da muffe e funghi e resistente a tutti gli acidi di uso domestico. Posa in opera e stuccatura: si possono usare le normali colle ceramiche da mosaico, utilizzando la tecnica della doppia spalmatura. Per la stuccatura usare esclusivamente stucchi epossidici, avendo cura di rimuovere l’eccedenza prima della completa essiccazione. Manutenzione e pulizia: si possono utilizzare i normali prodotti per il legno reperibili sul mercato, evitando assolutamente qualsiasi prodotto abrasivo.

CLEANING AFTER INSTALLATION

The cleaning after installation is of fundamental importance for all the subsequent steps and for a correct maintenance. Post-installation cleaning using acid detergents with a padding action such as Fila Deterdek or Faber Cement Remover must be carried out only once and only if this would result in the added bonus of giving the surface a more uniform aspect. Acid-cleaning will remove all residue associated with the installation and works in general, such as mortar, adhesive, paint and dirt. It is important to underline that 90% of complaints are due to a bad, or even inexistent cleaning after installation. In order to make sure that an acid detergent used for the cleaning does not compromise the filling of grout lines, it is necessary, before proceeding with cleaning, to wet the floors so that the grout lines are impregnated and protected from the corrosive action of the acid. It is recommended to follow these steps:

- First, remove any grease or similar substance from the floor using alkaline detergents
- Proceed with the cleaning of the surface
- Rinse the floors with an abundance of water
- The cleaning must be carried out 4-5 days after grouting (the grout must season) and within a maximum of 10 days after grouting, as, beyond this period of time the cleaning can be difficult, carefully follow the manufacturer’s instructions for the use of detergents.

It is always recommended to carry out a test on a sample tile (not installed), in particular in case of honed or polished products.

LAYING AND CLEANING DECORS PRODUCED WITH NATURAL COMPONENTS

3x30 CM. FASCIA SLATE ROSSO / SLATE NERO

The individual elements that make up the decorative piece are cut one by one from slabs of slate of various sizes, all with a thickness of 10 mm. Because they are made of natural stone, they are inevitably subject to surface and thickness irregularities. The decorative piece should be installed using normal ceramic mosaic adhesives and employing the back-buttering technique. Use exclusively epoxy grouts, being sure to remove any excess before it has dried completely. For maintenance and cleaning, use normal commercially-available products designed for marble/ natural stone. Do not use abrasive products.

2x30 CM. OAK GREY / WALNUT BEIGE

Wood component: each natural wood piece is individually handcrafted and varnished to make it completely non-absorbent. Substrate: the wood is mounted on WPC panels.This material is perfectly stable, fireproof and resistant to mould and fungi as well as all household acids. Installation and grouting:use normal ceramic mosaic adhesives and employ the back-buttering technique. Use exclusively epoxy grouts, being sure to remove any excess before it has dried completely. Maintenance and cleaning:use normal commercially-available wood products. Do not use abrasive products.

PULIZIA E MANUTENZIONE / CLEANING AND MAINTENANCE

MANUTENZIONE ORDINARIA

Si consiglia l'utilizzo di un comune detergente neutro diluito in acqua calda. Evitare l'utilizzo di prodotti acidi, alcalini, ceranti e/o impregnanti.

Nella pulizia ordinaria occorre limitare al massimo l'uso di mezzi abrasivi (ad esempio: paglietta di metallo, spugnette di ferro o acciaio). Questa precauzione diventa un obbligo nel caso di piastrelle con superficie lucida, più esposte ad effetti visibili di scalfitture, graffi...

In caso di sporchi più intensi o di superfici particolarmente strutturate, usare un detergente a base alcalina risciacquando al termine del lavaggio.

Nella pratica quotidiana occorre considerare che certi tipi di sporco (polvere, sabbia) aumentano l'effetto abrasivo del traffico pedonale. Cercare quindi di prevenire la presenza di questa tipologia di sporco dall'esterno, predisponendo l'utilizzo di zerbino o stuoino all'ingresso.

Per informazioni sui prodotti e sui servizi, visitate il sito www.fila.com

RIMOZIONE DI PATINE LUCIDE

Nei normali detergenti in commercio sono a volte contenute cere o additivi lucidanti che, lavaggio dopo lavaggio, depositano sul pavimento patine lucide, causa di noiose alonature. Patine di questo tipo possono essere depositate anche da alcuni stucchi per le fughe. Semplici alimenti come Coca Cola, vino, acqua, etc., cadendo sul pavimento tolgono questa patina lucida e ripristinano l'aspetto originale più opaco delle piastrelle. In mezzo al pavimento più lucido, le zone senza cera appaiono come aloni opachi, in realtà sono le uniche parti pulite del pavimento.

In questi casi, dopo aver fatto un test preventivo, bisogna:

- Togliere la patina lucida da tutto il pavimento con un tipo di detergente a base acida.
- Utilizzare per le pulizie quotidiane, detergenti neutri che non contengono né cere né patine lucidanti.

Per informazioni sui prodotti e sui servizi, visitate il sito www.fila.com

MANUTENZIONE STRAORDINARIA

Nel caso di tracce di sporco resistente alla pulizia ordinaria si raccomanda l'utilizzo di un detergen-te adeguato in funzione del tipo di sporco e comunque, prima dell'uso, fare sempre test preventivi su una piastrella non posata. Nella tabella “PRODOTTI PER LA PULIZIA E LA MANUTENZIONE” sono indicati i detergenti efficaci in funzione del tipo di macchia.

Per informazioni sui prodotti e sui servizi, visitate il sito www.fila.com

PAVIMENTI E RIVESTIMENTI METALLIZZATI

Per la pulizia e manutenzione di piastrelle metallizzate si raccomanda di non usare assolutamente detergenti acidi o alcalini. Usare esclusivamente prodotti con PH neutro come ad esempio Fila Cleaner o Floor Cleaner di Faber. In ogni caso verificare sempre prima il prodotto su una porzione di materiale non posato ed evitare di lasciare il detergente sulle piastrelle per più di 10-15 min. Risciacquare sempre abbondantemente con acqua.

Per informazioni sui prodotti e sui servizi, visitate il sito www.fila.com

TRATTAMENTO PRODOTTI LAPPATI E LEVIGATI

Lappatura e Levigatura sono lavorazioni che prevedono sempre l'asportazione di una parte superficiale dello smalto o del corpo stesso della piastrella. In tutti i pavimenti ceramici disponibili sul mercato, tale lavorazione, pur in presenza di materiali vetrosi o a bassissimo assorbimento, può comportare l'apertura di microporosità superficiali che a contatto con particolari tipi di sporco, possono risultare di difficile pulizia o presentare aloni difficilmente rimuovibili.

Per informazioni sui prodotti e sui servizi, visitate il sito www.fila.com

RACCOMANDAZIONI

Ricordiamo di non usare mai detergenti a base di acido fluoridrico (HP) o dei suoi composti, compresi antiruggine o smacchiatori di tipo spray che spesso lo contengono. Il danno che si potrà provocare sarà irreparabile in quanto non esiste pavimento sul mercato resistente a tale acido.

Per informazioni sui prodotti e sui servizi, visitate il sito www.fila.com

AVVERTENZE

Le caratteristiche di pulizia dei materiali variano in modo significativo in funzione delle diverse modalità di installazione, condizioni d'uso, tipologie di superfici e ambiente. In linea generale all'aumentare delle caratteristiche di antiscivolosità delle piastrelle, aumentano le difficoltà di pulizia. L'operatore professionale incaricato dell'intervento di manutenzione e pulizia, dovrà sempre procedere ad una preliminare verifica empirica, possibilmente su una porzione di materiale non posato, per ogni singolo tipo di intervento.

In caso di condizioni d'uso particolarmente gravose, di errata installazione o di pulizie effettuate in modo inadeguato FLAVIKER declina ogni responsabilità in merito all'efficacia delle operazioni di pulizia e manutenzione. Resta inteso che FLAVIKER non potrà essere ritenuta responsabile per eventuali danni o difetti dovuti ad errata installazione, negligente pulizia e manutenzione o inadeguata scelta della tipologia dei materiali installati e degli adesivi utilizzati con riguardo alla destinazione.

Le indicazioni contenute in questo paragrafo sono puramente indicative. Per notizie più approfondite rimandiamo a documentazione specializzata disponibile su cataloghi e siti web delle principali ditte produttrici di prodotti specifici per la pulizia dei pavimenti.

DAILY MAINTENANCE

It is recommended to clean the floor using a neutral detergent diluted in hot water. Avoid the use of acid, alkaline, waxing and/or impregnating products.

During ordinary cleaning procedures, it is recommended to limit the use of abrasive means such as scouring pads, iron and/or steel sponges. Taking this precaution is a must on glossy tiles, as they are more liable to scratching.

In case of intense dirt or textured surfaces, use an alkaline detergent, rinsing the floor with an abundance of water.

It is important to underline that certain types of dirt like dust or sand, increase the abrasive effect of foot traffic on the surface. The use of a door mat at the entrance can help prevent this.

Per informazioni sui prodotti e sui servizi, visitate il sito www.fila.com

REMOVAL OF FILMS ON THE FLOOR

The standard detergents available on the market sometimes contain waxes or polishing additives that, cleaning after cleaning, create a film on the floor and cause rims. This type of film can also develop when using certain types of grouts. Every-day stains on the floor, such as cola, wine, water, etc. remove this film and reveal the original, more opaque aspect of the tiled surface. On a glossy floor, these areas with no wax appear as rims but, in actual fact, they are the only clean areas of the floor itself.

In such cases, after having carried out a test, it is necessary to:

Remove the film from the floor using an acid detergent.

Use neutral detergents, which do not contain wax or polishing additives for everyday cleaning.

Per informazioni sui prodotti e sui servizi, visitate il sito www.fila.com

Per informazioni sui prodotti e sui servizi, visitate il sito www.fila.com

EXTRAORDINARY MAINTENANCE

In case of stains that are resistant to standard cleaning operations, it is recommended to use a specific detergent depending on the type of dirt and, every single time before using such detergent, to carry out a test on a non-installed sample tile. The chart “REMOVE STAINS” indicates the recommended detergents that are effective for certain specific stains.

Per informazioni sui prodotti e sui servizi, visitate il sito www.fila.com

METALLISED FLOOR AND WALL COVERINGS

For the cleaning and maintenance of metallised tiles, it is recommended not to use acid or alkaline detergents. Use products with neutral PH such as Fila Cleaner or Faber Floor Cleaner. Every single time, test the product on a sample tile that has not been installed and do not leave the detergent on the tiles for more than 10-15 minutes. Always rinse the surface with an abundance of water.

Per informazioni sui prodotti e sui servizi, visitate il sito www.fila.com

Per informazioni sui prodotti e sui servizi, visitate il sito www.fila.com

TREATMENT OF HONED AND POLISHED TILES

Honing and polishing are manufacturing processes that always remove a superficial part of the glaze or of the body of the tile itself. All honed and/or polished ceramic tiles available on the market have a micro-porous structure that, even when using low absorption vitreous materials, are vulnerable to attack from certain types of dirt that can attack the micro-porous structure and make cleaning operations very difficult.

Per informazioni sui prodotti e sui servizi, visitate il sito www.fila.com

RECOMMENDATIONS

Never use hydrofluoric acid-based detergents or its derivatives, such as rust-preventing products or spray stain-removers that often contain hydrofluoric acid. The use of hydrofluoric acid will irreparably damage the surface, as no ceramic tile floor available on the market is resistant to this acid.

Per informazioni sui prodotti e sui servizi, visitate il sito www.fila.com

WARNING

The cleaning features of materials considerably vary depending on the installation pattern, the conditions of use and the type of surface. As a general rule, as the anti-slip value of ceramic tile increases, the cleaning operations become more difficult. The professional technician in charge of the cleaning and maintenance must always carry out a preliminary test on a sample tile that has not been installed before proceeding with any cleaning operation.

In case of special conditions of use, incorrect installation or inadequate cleaning, Ceramiche FLA-VIKER will not be responsible for the effectiveness of cleaning and maintenance procedures. It is agreed that FLAVIKER will not be responsible for any damage or defects that are due to incorrect installation, cleaning and maintenance or due a wrong choice of materials and adhesives.

The above-stated instructions are merely indicative. For in-depth information, please consult the specific documents that are available on the catalogues and web-site of the manufacturers of detergents for ceramic floors.

PRODOTTI PER LA PULIZIA E LA MANUTENZIONE / CLEANING AND MAINTENANCE PRODUCTS

	TIPO DI MACCHIA TYPE OF STAIN		DETERGENTE CONSIGLIATO DETERGENT
MACCHIE INORGANICHE INORGANIC STAINS	CALCARE LIME	ACIDA ACID	DETERDEK (FILA) - CEMENT REMOVER (FABER)
	CEMENTO - SALNITRO CEMENT - SALTPETRE		DETERDEK (FILA) - CEMENT REMOVER (FABER)
	DEPOSITI CALCAREI DEPOSITS OF LIME		VIAKAL
	RUGGINE RUST		DETERDEK (FILA) - CEMENT REMOVER (FABER)
	SEGNI METALLICI METALLIC MARKS		DETERDEK (FILA)
MACCHIE ORGANICHE ORGANIC STAINS	BIRRA BEER	ALCALINA ALKALINE	PS/87 (FILA) - WAX REMOVER (FABER)
	CAFFÈ COFFEE		PS/87 (FILA) - SR/95 (FILA) - WAX REMOVER (FABER)
	COLA COCA COLA		PS/87 (FILA) - SR/95 (FILA) - WAX REMOVER (FABER)
	MACCHIE VEGETALI VEGETABLE FAT		WAX REMOVER (FABER)
	OLIO E GRASSO OIL AND GREASE		PS/87 (FILA) - WAX REMOVER (FABER)
	PNEUMATICI TIRES		PS/87 (FILA) - POLISHING CREAM (FABER)
	TINTURA PER CAPELLI HAIR DYE		PS/87 (FILA) - SR/95 (FILA) - COLOURED STAIN REMOVER(FABER)
	VINO WINE		PS/87 (FILA) - SR/95 (FILA) - OXIDANT (FABER)
MACCHIE SINTETICHE SYNTHETIC STAINS	VERNICE PAINT	SOLVENTE DISSOLVENT	PS/87 (FILA) - NOPAINTSTAR (FILA)
	BITUME BITUMEN		FILASOLV (FILA) - WAX REMOVER (FABER)
	CERA DI CANDELA CANDLE WAX		FILASOLV (FILA) - WAX REMOVER (FABER)
	INCHIOSTRO INK		PS/87 (FILA) - SR/95 (FILA) - COLOURED STAIN REMOVER(FABER)
	PENNARELLO FELT-TIP PEN		PS/87 (FILA) - SR/95 (FILA) - COLOURED STAIN REMOVER(FABER)
	RESIDUI DI SCOTCH REST OF STICKY TAPE		FILASOLV (FILA) - PS/87 (FILA) - SOLVENT STRIPPER (FABER)
ALONATURE RESIDUE RESIDUAL MARKS	SPORCO DELLE FUGHE TILE JOINT STAINS	DETERGENTE DETERGENT	FUGANET (FILA)
	ALONATURE VENTOSE STAINS FROM SUCTION CUPS		PS/87 (FILA)
	CERA PROTETTIVA PROTECTIVE WAX		PS/87 (FILA)

Per informazioni sui prodotti e sui servizi, visitate il sito www.fila.com

Attenzione: i prodotti a base acida possono corrodere marmo, granito, pietre naturali e metalli, pertanto evitarne l'uso nel caso di decori o inserti realizzati con questi materiali. Important: Acid products may corrode marble, granite, natural stone and metal. Avoid using in the presence of decoration or inserts in these materials.

PER L'USO ATTENERSI SCRUPolosAMENTE ALLE INDICAZIONI RIPOrtATE SULL'ETICHETTA. FOR THE CORRECT USE PLEASE FOLLOW THE INSTRUCTION MENTIONED ON THE LABEL.

Per informazioni sui prodotti e sui servizi, visitate il sito www.fila.com

CARATTERISTICHE TECNICHE / TECHNICAL CHARACTERISTICS

LE NORME ISO

QUESTE NORME, ELABORATE DALL'ISO TC 189, SOSTITUISCONO IN ITALIA, E NEI PAESI CHE LE HANNO RICONOSCIUTE, QUELLE PRECEDENTEMENTE ESISTENTI (EN).

THE ISO STANDARDS

THESE STANDARDS, DRAWN UP BY THE ISO TC189, REPLACE THE PREVIOUS (EN) STANDARDS IN ITALY AND IN THE OTHER COUNTRIES THEY ARE RECOGNIZED.

ALLEGATO ANNEX	GRUPPO GROUP	ASSORBIMENTO D'ACQUA (E) WATER ABSORPTION (E)
G	Bla	$E \leq 0,5\%$
H	Blb	$0,5\% < E \leq 3\%$
I	Blla	$3\% < E \leq 6\%$
J	Bllb	$6\% < E \leq 10\%$
K	Blll	$E > 10\%$

GRES PORCELLANATO / PORCELAIN TILES

CLASSIFICAZIONE SECONDO NORME UNI EN 14411 (ISO 13006) ALLEGATO G-Gruppo Bla
CLASSIFICATION IN ACCORDANCE WITH UNI EN 14411 (ISO 13006) ANNEX G-Group Bla

PROPRIETÀ FISICO-CHIMICHE PHYSICAL-CHEMICAL PROPERTIES	NORMA NORM	VALORE PRESCRITTO DALLE NORME VALUE PRESCRIBED FROM THE NORMS	VALORE FLAVIKER VALUE FLAVIKER
LUNGHEZZA E LARGHEZZA DIMENSIONE MEDIA DI OGNI PIASTRELLA LENGTH AND WIDTH OF THE AVERAGE-SIZES TILE	UNI EN ISO 10545/2	$\pm 0,5\%$	CONFORME ACCORDING
SPESSORE THICKNESS	UNI EN ISO 10545/2	$\pm 5\%$	CONFORME ACCORDING
RETTILINEARITÀ SPIGOLI WARPAGES OF EDGES	UNI EN ISO 10545/2	$\pm 0,5\%$	CONFORME ACCORDING
ORTOGONALITÀ WEDGING	UNI EN ISO 10545/2	$\pm 0,6\%$	CONFORME ACCORDING
PLANARITÀ FLATNESS	UNI EN ISO 10545/2	$\pm 0,5\%$	CONFORME ACCORDING
ASSORBIMENTO D'ACQUA WATER ABSORPTION	UNI EN ISO 10545/3	$E \leq 0,5\%$	CONFORME ACCORDING
RESISTENZA ALLA FLESSIONE BENDING STRENGTH	UNI EN ISO 10545/4	$\geq 35 \text{ N/mm}^2$	CONFORME ACCORDING
FORZA DI ROTTURA BREAKING STRENGTH	UNI EN ISO 10545/4	$\geq 1300 \text{ N}$	CONFORME ACCORDING
RESISTENZA ALL'ABRASIONE SUPERFICIALE PER PIASTRELLE SMALTATE ABRASION RESISTANCE FOR GLAZED TILES	UNI EN ISO 10545/7	IN FUNZIONE DELLA DESTINAZIONE D'USO ACCORDING TO THE DESTINATION OF FINAL USE	VEDI COLLEZIONE SEE COLLECTION
RESISTENZA AGLI SBALZI TERMICI THERMAL SHOCK RESISTANCE	UNI EN ISO 10545/9	RICHIESTA REQUIRED	RESISTE RESISTS
RESISTENZA AL GELO FROST RESISTANCE	UNI EN ISO 10545/12	RICHIESTA REQUIRED	INGELIVO FROST PROOF
RESISTENZA ALL'ATTACCO CHIMICO CHEMICAL RESISTANCE	UNI EN ISO 10545/13	-	RESISTE RESISTS
RESISTENZA ALLE MACCHIE RESISTANCE TO STAINING	UNI EN ISO 10545/14	GL \geq MINIMO CLASSE 3	RESISTE RESISTS
RESISTENZA ALLO SCIVOLAMENTO SLIP RESISTANCE	B.C.R.A. C.A.	μ 0,19 SCIVOLOSITÀ PERICOLOSA - DANGEROUSLY SLIPPERY $0,20 < \mu < 0,39$ SCIVOLOSITÀ ECCESSIVA - EXCESSIVELY SLIPPERY $0,40 < \mu < 0,74$ ATTRITO SODDISFACENTE - SATISFACTORY GRIP μ 0,75 ATTRITO ECCELLENTE - EXCELLENT GRIP	VEDI COLLEZIONE SEE COLLECTION
	B.C.R.A. G.B.		
	ASTM C 1028 (S.C.O.F.)	SLIP RESISTANT (> 0,60)	VEDI COLLEZIONE SEE COLLECTION
	DIN 51130	IN FUNZIONE DELL'AMBIENTE O DELLA ZONA DI LAVORO BASING ON THE ENVIRONMENT OR THE WORKING AREA	VEDI COLLEZIONE SEE COLLECTION
	DIN 51097	-	VEDI COLLEZIONE SEE COLLECTION
	ANSI A 137-1:2012	> 0,42	VEDI COLLEZIONE SEE COLLECTION
AS/NZS 4586 :2013	SRV : 35 - 44 SRV : 45 - 54	VEDI COLLEZIONE SEE COLLECTION	

VARIAZIONE CROMATICA
SHADE VARIATION

VEDI COLLEZIONE
SEE COLLECTION



aspetto uniforme
uniform appearance
V1



lieve variazione
slight variation
V2



moderata variazione
moderate variation
V3



forte variazione
substantial variation
V4

CARATTERISTICHE TECNICHE / TECHNICAL CHARACTERISTICS

PASTA BIANCA DA RIVESTIMENTO / WHITE BODY WALL TILES

W&P

PROPRIETÀ FISICO - CHIMICHE PHYSICAL - CHEMICAL PROPERTIES	NORMA NORM	VALORE PRESCRITTO DALLE NORME VALUE PRESCRIBED FROM THE NORMS	PASTA BIANCA DA RIVESTIMENTO W&P W&P WHITE BODY WALL TILES VALORE FLAVIKER FLAVIKER VALUE CLASSIFICAZIONE SECONDO NORME EN 14411 (ISO 13006) - Gruppo Bllb CLASSIFICATION IN ACCORDANCE WITH EN 14411 (ISO 13006) - Group Bllb	PASTA BIANCA DA RIVESTIMENTO WHITE BODY WALL TILES VALORE PRESCRITTO DALLE NORME VALUE PRESCRIBED FROM THE NORMS CLASSIFICAZIONE SECONDO NORME EN 14411 (ISO 13006) - Gruppo Blll CLASSIFICATION IN ACCORDANCE WITH EN 14411 (ISO 13006) - Group Blll
LUNGHEZZA E LARGHEZZA DIMENSIONE MEDIA DI OGNI PIASTRELLA LENGTH AND WIDTH OF THE AVERAGE-SIZES TILES	UNI EN ISO 10545/2	$l \leq 12 \text{ cm} : \pm 0,5\%$ $l > 12 \text{ cm} : \pm 0,3\%$	solo Rettificato only Rectified	CONFORME ACCORDING
SPESSORE THICKNESS	UNI EN ISO 10545/2	$\pm 10\%$	$\pm 5,0\%$	CONFORME ACCORDING
RETTILINEARITÀ SPIGOLI WARPAGES OF EDGES	UNI EN ISO 10545/2	$\pm 0,3\%$	$\pm 0,3\%$	CONFORME ACCORDING
ORTOGONALITÀ WEDGING	UNI EN ISO 10545/2	$\pm 0,5\%$	$\pm 0,5\%$	CONFORME ACCORDING
PLANARITÀ FLATNESS	UNI EN ISO 10545/2	+ 0,5% - 0,3%	$\pm 0,3\%$	CONFORME ACCORDING
ASSORBIMENTO D'ACQUA WATER ABSORPTION	UNI EN ISO 10545/3	> 10%	$E \leq 6\%$	CONFORME ACCORDING
RESISTENZA ALLA FLESSIONE BENDING STRENGTH	UNI EN ISO 10545/4	per spessore $\geq 7,5 \text{ mm}$ >15 N/mm ² per spessore < 7,5 mm >12 N/mm ²	$\geq 30 \text{ N/mm}^2$	CONFORME ACCORDING
FORZA DI ROTTURA BREAKING STRENGTH	UNI EN ISO 10545/4	-	> 700 N	-
RESISTENZA AGLI SBALZI TERMICI THERMAL SHOCK RESISTANCE	UNI EN ISO 10545/9	RICHIESTA REQUIRED	RICHIESTA REQUIRED	RESISTE RESISTS
RESISTENZA AL GELO FROST RESISTANCE	UNI EN ISO 10545/12	RICHIESTA REQUIRED	NON RICHIESTA NOT REQUIRED	-
RESISTENZA ALLE MACCHIE RESISTANCE TO STAINING	UNI EN ISO 10545/14	CLASSE 3 MINIMO CLASS 3 MINIMUM	GL \geq MINIMO CLASSE 3	CLASSE 4 MIN CLASS 4 MIN
DILATAZIONE DELL'UMIDITÀ MOISTURE EXPANSION	UNI EN ISO 10545-10	-	$\leq 0,1 \text{ (mm/m)}$	-

Un ambiente Flaviker, oltre a distinguersi per il design, è sinonimo di qualità Made in Italy, ottenuta seguendo standard di sostenibilità sempre più evoluti.

L'80% dei materiali contenuti in questo catalogo viene prodotto con impasto ECO-BODY, contenente un 40% minimo di materie prime di qualità, recuperate da lavorazioni interne ed esterne; il valore di questa operazione è certificato da Bureau Veritas, che accredita i prodotti ECO-BODY anche all'interno del sistema internazionale LEED.

Flaviker promuove l'edilizia sostenibile, per questo è socio di Green Building Council Italia, l'associazione italiana dei leader che operano per trasformare il mercato dell'edilizia verso la sostenibilità ambientale. I soci GBC Italia promuovono la responsabilità ambientale, economica e sociale con contributi concreti all'innovazione, nel modo in cui gli edifici sono progettati, realizzati e utilizzati.

An Flaviker setting stands out as the standard-bearer of the Made in Italy design by pursuing continuously evolving sustainability standards.

Almost 80% of the materials illustrated in this catalogue is produced using the ceramic mixture ECO-BODY, which contains a minimum of 40% high-quality recycled material recovered from internal and external industrial processes. The sustainability performance in these operations is officially certified by Bureau Veritas, that also validates ECO-BODY products to the standards of the LEED international rating system.

With a view to promoting sustainable building, Flaviker has become a member of Green Building Council Italia, the Italian association of top leaders with an aim to implementing more sustainable practices in the building industry. The members of GBC Italia promote environmental, economical and social responsibility, while contributing in a concrete way to innovation in terms of building design, realization and utilization.



GUIDA ALLA CONSULTAZIONE / CONSULTATION GUIDE

CATEGORIA PREZZO:

M= prezzo espresso in Euro da calcolarsi al mq
P= prezzo espresso in Euro da calcolarsi al pezzo

Pricing categories:

M= price in euro per square meter
P= price in euro per unit

30x30

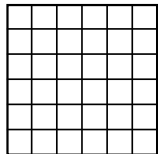

Formato
Size

Codice articolo
Article code

UC MO 101

MOSAICO

M. 104,00



Pezzi per scatola
Pieces per box



PIASTRELLE PER PAVIMENTI

Floor tiles | Carregales pour sol
Bodenfliesen | Baldosas para pavimentos
НАПОЛЬНАЯ ПЛИТКА



PIASTRELLE PER RIVESTIMENTI

Wall Tiles | Faiences
Wandfliesen | Baldosas para revestimientos
ОБЛИЦОВОЧНАЯ ПЛИТКА



SPESSORE

Thickness | Epaisseur
Stärke | Espesor
ТОЛЩИНА



RESISTENZA AL GELO

Frost resistance | Résistance au gel
Frostbeständigkeit | Resistencia a la helada
МОРОЗОСТОЙКОСТЬ



RESISTENZA ALLO SCIVOLAMENTO

Skid resistance | Résistance à la glissance
Rutschfestigkeitskoeffizient
Resistencia al deslizamiento
КОЭФФИЦИЕНТ СОПРОТИВЛЕНИЯ СКОЛЬЖЕНИЮ



GRES PORCELLANATO TUTTA MASSA

Full body porcelain
Grès cérame en pleine masse
Vollgemischtes durchgefärbtes Feinsteinzeug
Gres porcelánico toda masa
КЕРАМОГРАНИТ, ОКРАШЕННЫЙ ПО ВСЕЙ ТОЛЩИНЕ



RESISTENZA ALL'ABRASIONE PROFONDA

Resistance to deep abrasion
Résistance à l'abrasion profonde
Widerstand gegen tiefenverschleiss
Resistencia a la abrasión profunda
СТОЙКОСТЬ К ГЛУБОКОМУ ИСТИРАНИЮ

VARIAZIONE CROMATICA

Colour shade variation | Variation de nuances
Farbabweichung | Variación cromática | ИЗМЕНЕНИЕ ЦВЕТА



V1 ASPETTO UNIFORME

V1 uniform appearance | V1 aspect uniforme
V1 einheitliche Optik | V1 aspecto uniforme
V1 ОДНОРОДНЫЙ ВИД



V2 LIEVE VARIAZIONE

V2 minimal variation | V2 légère variation
V2 leichte farbabweichung | V2 variación ligera
V2 ЛЕГКОЕ ИЗМЕНЕНИЕ



V3 MODERATA VARIAZIONE

V3 moderate variation | V3 variation modérée
V3 mässige farbabweichung | V3 variación moderada
V3 УМЕРЕННОЕ ИЗМЕНЕНИЕ



V4 FORTE VARIAZIONE

V4 substantial variation | V4 effet dénuancé très accentué
V4 starke farbabweichung | V4 variación evidente
V4 СИЛЬНОЕ ИЗМЕНЕНИЕ



PRODOTTI COMPOSTI DA ECO-BODY,

IMPASTO STANDARD LEED

LEED standard products | Produits à leed standard
Produkte gemäß LEED-Standard | Productos conformes a estándar leed
Изделия соответствуют стандарту LEED

RETT.

RETTIFICATO

Rectified | Rectifié | Rechtwinklig | Rectificado | КАЛИБРОВАННЫЙ

LAPP.

LAPPATO

Honed | Adduci | Halbpolierte | Recubierto | ШЛИФОВАННЫЙ

LA FINITURA LAPPATA È SEMPRE RETTIFICATA

The lapped finish is always rectified
La finition rodée est toujours rectifiée
Die geläppte Ausführung is immer geschliffen
El acabado pulido es siempre rectificado
Изделия со шлифованной отделкой, как правило, калиброваны.

1) APPROVAZIONE - Gli ordini pervenuti sono per noi impegnativi solo dopo la nostra conferma scritta.

2) CONSEGNA - La consegna del materiale s'intende avvenuta a carico effettuato presso i nostri magazzini.

Tutti i rischi di trasporto, compresi ammanchi, rotture, deterioramenti e manomissioni sono a carico del Committente anche se il prezzo pattuito è franco di porto, FOB o C&F. Gli accordi con spedizionieri s'intendono sempre conclusi in nome e per conto del Committente che fin d'ora ratifica ed accetta l'operato.

3) TERMINI DI CONSEGNA - I termini di consegna hanno carattere indicativo, eventuali ritardi nelle consegne, interruzioni, sospensioni totali o parziali delle forniture non daranno diritto ad indennizzi o risarcimento danni.

4) CONTESTAZIONI - La garanzia della merce è limitata al solo, ed esclusivamente, materiale di prima scelta, con una tolleranza del 5% circa. Le differenze di tonalità non potranno essere denunciate come vizio del materiale. Eventuali reclami in merito alla qualità, tipo del materiale, dovranno pervenirci entro 8 giorni dalla data di consegna. Il compratore s'impegna a tenere a disposizione le partite contestate così da consentire il controllo dei difetti denunciati, in ogni caso la posa in opera ci esonera da qualsiasi responsabilità. Eventuali vizi o difetti di qualità della merce, ove siano denunciati nei termini di legge ed accertati o riconosciuti, danno diritto solamente alla sostituzione dei materiali difettosi, a condizione della preventiva restituzione delle merci contestate, e, su autorizzazione scritta dell'operazione di resa, restando tassativamente esclusi la risoluzione del contratto e qualsiasi risarcimento danni.

5) DIMENSIONI E TONALITA' - I nostri materiali sono da classificarsi fra i prodotti cotti ad alta temperatura e come tali possono presentare differenze tra le dimensioni dichiarate e quelle effettivamente consegnate. Così si dica per le differenze di tono all'interno della medesima partita. Quanto sopra perciò non potrà essere oggetto di reclamo da parte del committente.

6) IMBALLO E QUANTITA' - Il buono stato degli imballi e della loro confezione nonchè della quantità consegnata resta accertato con l'accettazione della merce da parte del vettore. Questi, firmando la Bolla di Accompagnamento, si rende responsabile del buono stato del materiale e del quantitativo. Il compratore nel caso si verificchino rotture ed ammanchi dovrà chiedere eventuali danni o risarcimenti al vettore.

7) RESI - Per nessuna ragione l'acquirente potrà restituire il materiale senza nostra espressa preventiva autorizzazione scritta e tutte le spese sono a carico del Committente.

8) ANNULLI - Non verranno accettati annullamenti di ordini se il materiale è già stato prodotto o se è già stata avviata la lavorazione e molto più se è già stata effettuata la spedizione. L'annullamento dell'ordine comporterà in ogni caso l'obbligo da parte del Committente di pagare l'intera fornitura. Nel caso che sia fattibile l'accettazione dell'annullamento il Cliente sarà tassativamente tenuto a rifondere tutte le spese sostenute dal produttore fino a quel momento.

9) PREZZI - I prezzi riportati sui nostri listini non sono per noi impegnativi. Ci riserviamo il diritto di modificarli prima dell'accettazione dell'ordine.

10) PAGAMENTI - I pagamenti devono essere effettuati solo presso la nostra sede. Il ritardo di 10 giorni di ogni pagamento dovuto, o la mancata copertura nel termine stesso di un titolo di credito, girato o ceduto o emesso dal committente, costituisce grado di insolvenza. In tal caso sarà nostra facoltà sospendere le forniture ed annullare ogni rapporto in corso; immediatamente esigere l'integrale pagamento di ogni rapporto in corso; esigere l'integrale pagamento di ogni nostro credito ed agire giudizialmente al riguardo, in via esecutiva o cautelare nonchè per il risarcimento danni; in ogni caso, trascorsi 10 giorni da ogni pagamento dovuto, siamo autorizzati a emettere tratta a vista con spese senza preavviso. Inoltre decorreranno sul debito scaduto gli interessi moratori annui calcolati nella misura del tasso "prime rate" corrente maggiorato di 5 punti percentuali.

11) UNITÀ MINIMA DI VENDITA - Non si effettuano vendite inferiori alla scatola.

12) RISERVATO DOMINIO - Il materiale anche se spedito e regolarmente fatturato resta di nostra proprietà fino al pagamento totale della fornitura medesima anche in caso di passaggio o vendita terzi.

13) FORO COMPETENTE - Per qualsiasi controversia sarà esclusivamente competente il foro di Modena.

GENERAL SALES TERMS AND CONDITIONS

1) APPROVAL - All orders that we receive are considered to be binding only after our written confirmation has been issued.

2) DELIVERY - The materials are intended as delivered upon loading at our warehouses. All transport risks, including missing pieces, breakage, deterioration and tampering are the sole responsibility of the Client, even if the price agreed upon is carriage free, FOB, ar C&F. Agreements with forwarding agents are intended as concluded in the name of and on behalf of the Client, who hereby confirms and accepts their terms and conditions.

3) TERMS OF DELIVERY - The terms of delivery are indicative, eventual delays in the delivery, interruptions, or total or partial suspensions of the supply do not allow any right to indemnification or compensation for damages.

4) DISPUTES - The guarantee of the goods is limited only and exclusively to first rate materials, with a tolerance of approximately 5%. The difference in shades of colour cannot be declared as a material defect. Eventual complaints regarding the quality or the type of material must be submitted within 8 days from the date of delivery. The purchaser agrees to make available the disputed lots in order that the declared defects may be controlled. In any case, the installation exonerates the manufacturer from any liability. Eventual manufacturing defects or quality defects in the goods, where declared according to law and ascertained or recognized, give right only to the replacement of the defective materials, provided that the goods have been returned previously and the written authorization of the return operation has been issued, the resolution of the contract as well as any compensation for damages is peremptorily waived and excluded.

5) DIMENSIONS AND TONALITY - Our materials are classified as products fired at high temperatures and as such may present discrepancies between the dimensions declared and those actually delivered. The same applies for differences in colours within the same production lot. Therefore, the client may not present a dispute regarding above mentioned product characteristic.

6) PACKAGING AND QUANTITY - The good condition of the packaging and cartons as well as the quantity delivered are verified upon acceptance of the goods by the forwarding agent. The forwarding agent declares himself responsible for the condition and quality of the goods upon signing the packing list. In case of missing pieces of breakage, the purchaser must ask for eventual damages or compensation from the forwarding agent.

7) RETURNS - For no reason will purchaser be able to return the material without our express prior written authorization and all the costs of the return will be assumed by the Client.

8) CANCELLATIONS - Order cancellations will not accepted if the material has already been produced or if the production has already begun, and more so if the materials have already been shipped. In any case, the Client is obliged to pay the entire sum of the supply if the order is cancelled. If the acceptance of the cancellation is feasible, the Client will be peremptorily obliged to reimburse all the expenses sustained by the producer up to that moment.

9) PRICES - The prices on our price list are not binding. We reserve the right to modify prices before accepting an order.

10) PAYMENT - Payments must be made only in our main office. Delays of more than 10 days for each payment due or insufficient funds during rhe same term of a check, whether endorsed of transferred, or issued by the customer, constitutes bad debt. In this case, we reserve the right to suspend supply and annual all ongoing relations, immediately require total payment of all ongoing relations; require total payment of each credit and to make legal recourse, whether executive or precautionary, as well as request compensation for damages. In any case, after 10 days any payment due,we are authorized to issue an on-sight draft with expenses without notice. Furthermore, annual penalty interest will accumulate on the expired debt to be calculated according to the current “Prime rate” plus five (%) percentage points.

11) MINIMUM PACKAGING REQUIREMENTS - Sales of less than one box will not be allowed.

12) SELLER'S LIEN - The material, even is shipped and regularly invoiced, remains our property until payment in full of the invoice itself, even in case of passage or sale to third parties.

13) PLACE OF JURISDICTION - For any eventual dispute, the only place of jurisdiction will be the Modena Tribunal.

LOGISTIC SERVICES

CANCELLATION OF ORDERS – for the authorized cancellation of orders for materials already delivered to our warehouse, and for authorized returns of the goods, 15% of the taxable value will be charged, with a minimum fixed contribution of € 20 towards transport and reselection costs.

MINIMUM ORDERS – for limited orders to complete a previous order or for single deliveries, with a taxable value of less than € 100, there is a fixed net surcharge of € 20.

ORDERS FOR LESS THAN 1 PALLET - for orders of less than one pallet, it will be applied a fix net surcharge of 1,50 €/m2.

URGENT DELIVERIES – for orders to be prepared within 24 hours, with a maximum quantity of 2 articles, there is a fixed net surcharge of € 30.

PACKAGING

CHARGES Special packaging for wide collections will be charged according to the schedule at the end of each collection.

RETURNS The packaging may be returned in its original condition for credit against future orders.

CONDITIONS GÉNÉRALES DE VENTE

1) ACCEPTATION - Les commandes parvenues ne seront valables de manière définitive qu’après confirmation écrite de notre part.

2) LIVRAISON - La livraison du matériel est à considérer effectuée au moment du chargement dans nos entrepôts. Tous les risques de transport, tels que les manques, les casses ,détériorations ou endommagements sont à la charge de l’Acheteur, même lorsque le prix convenu est franco , FOB ou C&F. Les accords conclus avec les transporteurs sont à considérer toujours au nom et pour compte de l’Acheteur, qui confirme et accepte le conditions au préalable.

3) DÉLAIS DE LIVRAISON - Les délais de livraison ont un caractère indicatif; les éventuels retards de livraisons, interruptions, suspensions totales ou partielles des fournitures ne donneront droit à aucun dédommagement ou remboursement et intérêts.

4) CONTESTATIONS - La garantie de la marchandise se limite seulement et exclusivement au materiel de premier choix, avec une marge de tolérance de 5% environ. Les différences de nuances ne pourront être dénoncées comme vice du matériel. Les éventuelles réclamations relatives à la qualité, au type de matériel, devront nous parvenir dans les 8 jours à partir du jour de livraison. L’Acheteur s’engage à mettre à disposition les parties contestées de manière à permettre le contrôle des défauts déclarés, sachant que la pose nous libère quoiqu’il en soit de toute responsabilité. Les éventuels vices ou défauts de qualité de la marchandise, si déclarés en vertu des termes de loi et confirmés ou reconnus, ne donnent droit qu’a la substitution des matériaux défectueux, à condition que les marchandises contestées ne soient rendues préalablement et, sur autorisation écrite de l’opération de restitution, en renonçant et en excluant ainsi de manière formelle la résolution du contrat tout comme les éventuels dommages et intérêts.

5) DIMENSIONS ET TONS - Nos matériels se classent parmi les produits cuits à haute températures et peuvent présenter en tant que tels des différences entre les dimensions déclarées et celles effectivement livrées.

C’est ainsi que sont considérées les différences de tons à l’intérieur d’un même lot. C’est pourquoi, en vertu des conditions présentées précédemment, ceci ne pourra faire l’objet d’aucune réclamation de la part de l’Acheteur.

6) EMBALLAGE ET QUANTITES - Le bon état des emballages et de leur confection, ainsi que de la quantité livrée est confirmé après acceptation de la marchandise de la part du transporteur. Ce dernier, en signant le Bon de Livraison, se tient responsable du bon état du matériel et de la quantité. En cas de casses ou manques, l’acheteur devra demander des éventuels dommages et intérêts ou dédommagements au transporteur.

7) RESTITUTIONS - En aucun cas l’Acheteur ne pourra rendre la matériel sans préalablement recevoir une autorisation écrite de notre part et tous les frais sont à la charge de l’Acheteur.

8) ANNULLATIONS - Aucune annulation de commandes ne sera acceptée si le matériel a déjà été produit ou si la phase de production a déjà été commencé, ni même si la livraison a déjà été effectuée. L’annulation de la commande comportera dans tous les cas l’obligation de la part de l’Acheteur de payer la totalité de la marchandise. Au cas ou l’acceptation de l’annulation est faisable, le Client sera formellement tenu à recouvrir tous les frais engendrés par le producteur jusqu’alors.

9) PRIX - Les prix reportés sur nos catalogues ne sont pas définitifs. Nous nous réservons le droit de les modifier avant l’acceptation de la commande.

10) PAIEMENTS - Les paiements ne doivent être effectués qu’auprès de notre siège. Le retard de plus de 10 jours de tout paiement dû ou la non couverture dans le même délai d’un titre de crédit, transféré ou cédé,ou bien émis par l’Acheteur, consitue un niveau d’insolvabilité. Dans ce cas, il est en notre pouvoir de suspendre les livraisons et annuler tout rapport en cours; d’exiger le paiement intégral et immédiat de nos crédits; d’exiger le paiement intégral de tout en notre faveur et d’agir judiciairement à cet égard, de manière exécutive ou préventive ainsi que pour les dommages et intérêts. Dans tous les cas, aussitôt qu’un paiement du dépasse le délai des 10 jours, nous sommes autorisés à émettre une traite à vue avec frais sans préavis. En outre, les intérêts moratoires annuels calculés en fonction du taux “premiers versements” courant majoré à 5 points pourcents, prendrant effet sur le débit dépassé.

11) MINIMUM UNITE DE VENTE - Aucune vente inférieure à la boite ne peut être effectuée.

12) DOMAINE RÉSERVÉ - Le matériel, même si livré et régulièrement facturé reste notre propriété jusqu’au paiement total de ladite marchandise, même en cas de passage ou vente à un tiers.

13) TRIBUNAL COMPETENT - Le Tribunal de Modena sera compétent de manière exclusive en cas de litige.

SERVICES LOGISTIQUES

ANNULATION D’UNE COMMANDE – pour annuler une commande de matériaux déjà livrés à notre dépôt, et pour une restitution autorisée, une somme équivalente à 15 % de la valeur imposable vous sera débitée, avec un montant fixe minimum de 20€, en tant que participation aux frais de transport et de reselection.

COMMANDES MINIMUM – pour les commandes visant à “compléter” ou constituant des “expéditions individuelles” dont la valeur imposable est inférieure à 100€, un supplément de 20€ net et fixe sera appliqué.

MATÉRIEL DÉPALETTISÉ – pour des commandes dont le métrage est inférieur à une palette complète, un supplément correspondant à 1,50 euro net le m2 sera appliqué.

LIVRAISONS URGENTES – pour la préparation de commandes à livrer dans les 24 heures, avec une limite maximum de 2 articles en tout, un supplément de 30€ net et fixe sera appliqué.

EMBALLAGES

COÛT Les emballages spéciaux des collections Wide seront facturés au coût indiqué dans le tableau resumé de chaque collection.

RETOUR Ils pourront être retournés et faire l’objet d’un remboursement à condition qu’ils soient en bon état.

ALLGEMEINE VERKAUFSBEDINGUNGEN

1) BESTÄTIGUNG - Eingegangene Bestellungen sind für uns nur verbindlich, wenn sie schriftlich durch uns bestätigt wurden.

2) LIEFERUNG - Die Lieferung des Materials ist für uns mit dessen Beladung bei unserem Lager abgeschlossen. Alle durch den Transport bedingten Risiken, einschließlich Fehlmengen, Bruch, Beschädigung und sonstige Beeinträchtigungen gehen zu Lasten des Auftraggebers, auch wenn der vereinbarte Preis frachtfrei. FOB oder C&F ist. Die Vereinbarungen mit den Speditionsunternehmen werden im Namen und auf Rechnung des Auftraggebers getroffen, der die Entlastung bestätigt und erteilt.

3) LIEFERFRISTEN - Die Lieferfristen sind ungefähre Angaben; im Falle einer Verzögerung, Unterbrechung bzw. teilweiser oder kompletter Aussetzung der Lieferungen besteht kein Recht auf Entschädigung oder Schadenerstatz.

4) BEANSTANDUNGEN - Die Garantie auf die Ware bezieht sich ausschließlich auf Material erster Wahl, bei einer Toleranz von ca. 5%. Unterschiede bei Farbtönen können nicht als Materialfehler geltend gemacht werden. Eventuelle Beanstandungen in Bezug auf die Qualität und Materialart müssen innerhalb von 8 Tagen ab dem Lieferdatum bei uns eingehen. Der Käufer verpflichtet sich, die beanstandeten Warenpartien für die Überprüfung der angezeigten Mängel zur Verfügung zu halten. Die Verlegung des Materials befreit uns in jedem Fall von jeglicher Haftung. Eventuelle Fehler oder Qualitätsmängel der Ware, sofern diese innerhalb der gesetzlich vorgeschriebenen Fristen gemeldet, überprüft und anerkannt wurden, beinhalten lediglich das Recht auf einen Umtausch der fehlerhaften Materialien, unter der Bedingung, dass die beanstandete Ware vorher, nach schriftlicher Genehmigung der Warenrückgabe, zurückgeschickt wurde und unter Verzicht und Ausschluss des Anspruchs auf eine Vertragsauflösung oder jegliche Art von Schadenersatz.

5) ABMESSUNGEN UND FARBTÖNE - Unsere Materialien sind als Produkte klassifiziert, die bei hohen Temperaturen gebrant werden, weshalb es sein kann, dass die tatsächlichen Abmessungen von den genannten Abmessungen abweichen. Das gleiche gilt für Farbunterschiede innerhalb desselben Warenpostens. Diese Umstände geben dem Auftraggeber kein Recht zu Beanstandungen.

6) VERPACKUNG UND MENGE - MitAnnahme der Ware durch das Beförderungsunternehmen gelten der gute Zustand der Verpackungen sowie die übergebene Warenmenge als bestätigt. Das Transportunternehmen übernimmt mit Unterzeichnung des Versandscheins die Verantwortung für den guten Zustand und die Menge des Materials. Der Käufer muss sich im Fall von Brüchen oder Fehlware für eventuelle Shäden oder Entschädigungen as das Beförderungsunternehmen wenden.

7) WARENRÜCKGABE - Der Käufer kann die Ware in keinem Fall ohne unsere ausdrückliche schriftliche Genehmigung zurückgeben; alle entstehenden Kosten werden vom Auftraggeber übernommen.

8) STORNIERUNGEN - Auftragsstornierungen werden nicht akzeptiert, wenn das Material bereits hergestellt wurde, die Produktion angelaufen ist oder die Ware gar bereits verschickt wurde. Bei der Stornierung einer Bestellung ist der Auftraggeber in jedem Fall verpflichtet, die gesamte Lieferung zu bezahlen. Falls die Stornierung akzeptiert wird, ist der Kunde verpflichtet, alle Kosten zu übernehmen, die dem Hersteller bis zu diesem Zeitpunkt entstanden sind.

9) PREISE - Die in unserer Preisliste angegebenen Preise sind für uns nicht verbindlich. Wir behalten uns das Recht vor, diese vor de Beststellungsannahme zu ändern.

10) ZAHLUNG - Die Zahlungen können nur direkt an uns erfolgen. Eine Verspätung von mehr als 10 tagen jeder geschuldeten Zahlung bzw. die fehlende Deckung eines girierten, abgetretenen oder vom Auftraggeber ausgestellten Kreditpapiers innerhalb desselben Zeitraums wird als Zahlunsunfähigkeit gewertet. In diesem Fall haben wir das Recht, die Lieferungen auszusetzen und jedes bestehende Geschäftsverhältnis abzubrechen; unverzüglich die vollständige Zahlung aller unserer Forderungen im Rahmen eines Vollstreckungs- oder Sicherstellungsverfahrens rechtlich zu beanspruchen, ebenso wie eine Entschädigung; in jedem fall sind wir 10 Tage nach Ablauf der Zahlungsfrist berechtigt, ohne Vorankündigung eine Sichttratte zuzüglich der entsprechenden Kosten auszustellen. Außerdem werden auf den geschuldeten Betrag die jährlichen Verzugszinsen in Höhe des laufenden, um fünf Prozentpunkte erhöhten Privatdiskontsatzes berechnet.

11) VERPACKUNGSGRÖSSE - Es werden keine Mengen unterhalb der Größe eines Kartons verkauft.

12) EIGENTUMSVORBEHALT - Das Material bleibt auch bei regulärem Transport und normaler Rechnungsstellung bis zur vollständigen Bezahlung der Lieferung in unserem Eigentum, auch im Falle der Weitergabe oder des Verkaufs an Dritte.

13) GERICHTSSTAND - Gerichtsstand in Streitfällen ist ausschließlic das Gericht Modena.

LOGISTIC SERVICES

STORNIERUNG VON BESTELLUNGEN - Für die Genehmigte Stornierung von Bestellungen von bereits an unser Lager gelieferten Materialien, und für autorisierte Rückgaben, werden 15% des Steuerwertes bzw. mindestens 20€ als Kostenbeitrag für den Transport und die erneute Auswahl in Rechnung gestellt.

MINDESTBESTELLUNGEN - für beschränkte Bestellungen zur „Fertigstellung“ oder „Einzelabfertigung“, deren Steuerwert unter 100 € liegt, wird ein fixer Nettoaufschlag von 20 € in Rechnung gestellt.

KOMMISSIONSZUSCHLAG - zu allen als eine volle Paletten geringere Auftraege wird ein Zuschlag von 1,50 €/Qm angewandt werden.

DRINGENDE AUFTRAEGE - Zu Auftraegen, die ausnahmweise in 24 Stunden abgewickelt werden sollen, wird einen Fix-Zuschlag von 30,00 € angewandt werden.

VERPACKUNGEN

BELASTUNG Die Verpackungskosten für die WIDE Serien werden auf die Übersicht von jeder Serie bekanntgegeben.

ZURÜCKERSTATTUNG Unter der Voraussetzung, dass sie in gutem Zustand zurückerstattet werden, können sie zurückgesandt und wieder gutgeschrieben werden.

ОБЩИЕ УСЛОВИЯ ПРОДАЖИ

1 ПОДТВЕРЖДЕНИЕ - Поступившие к нам заказы действительны только после нашего письменного подтверждения.

2 ПОСТАВКА - Поставка материала считается выполненной в момент окончания погрузки на наших складах. Заказчик несет все риски, связанные с транспортировкой, включая недостачу, поломку, порчу и нарушение целостности упаковки, также если на продукцию установлена цена франко-порт, FOB или C&F. Соглашения с экспедиторами всегда заключаются от имени и за счет Заказчика, который с момента заключения соглашения утверждает и принимает проделанную работу.

3 СРОКИ ПОСТАВКИ - Сроки поставки имеют ориентировочный характер, возможная задержка поставки, ее приостановка, частичное или полное прекращение не дают права на возмещение убытков или компенсацию за ущерб.

4 ПРЕДЪЯВЛЕНИЕ ПРЕТЕНЗИЙ - Гарантия на товар распространяется только и исключительно на первосортный материал с допусκαемым отклонением приблизительно на 5%. Различия в оттенках не будут считаться дефектом материала. Возможные претензии в отношении качества, типа материала должны быть предъявлены в течение 8 дней с даты поставки. Покупатель обязуется предоставить признанные им дефектными партии товара для проверки обоснованности претензии; в любом случае, после укладки материала мы не несем никакой ответственности. Возможные выявленные или подтвержденные недостатки или дефекты качества товара, при условии, что покупатель заявил о них в течение установленных законом сроков, дают покупателю право только на замену дефектного материала, которая осуществляется после возврата дефектного товара и на основании акта о возврате товара, составленного в письменной форме, при этом категорически исключается отказ от договора или его расторжение, а также какое-либо возмещение убытков.

5 РАЗМЕРЫ И ОТТЕНКИ - Наши материалы относятся к продуктам, которые подвергаются обжигу при высокой температуре, поэтому заявленные и реальные размеры поставленных изделий могут отличаться. Это касается и различий в оттенках изделия из одной и той же партии. В связи с этим размеры и оттенки не могут быть предметом рекламации со стороны заказчика.

6 УПАКОВКА И КОЛИЧЕСТВО - Перевозчик должен проконтролировать груз по количеству и целостности упаковки при приемке товара. Перевозчик, подписывая Сопроводительную Накладную, несет ответственность за сохранность материала и за его количество. В случае обнаружения повреждений и недостачи возможные претензии о возмещении ущерба за понесенные убытки покупатель должен предъявлять перевозчику.

7 ВОЗВРАТ ТОВАРА - Покупатель не может ни на каком основании осуществлять возврат товара без нашего предварительного письменного согласия. Все расходы будут отнесены на счет Заказчика.

8 АННУЛИРОВАНИЕ ЗАКАЗА - Отмена заказа не будет приниматься, если материал был уже изготовлен, или если уже было начато его производство, а тем более, если уже была произведена отправка. В любом случае, при отмене заказа Заказчик будет обязан произвести оплату всей поставки. Если отмена заказа будет возможна, Клиент должен будет возместить все расходы, понесенные производителем до момента отмены.

9 ЦЕНЫ - Цены, указанные в наших прайс-листах, имеют ориентировочный характер. Мы оставляем за собой право изменить цены перед принятием заказа

10 ПЛАТЕЖИ - Оплата товара должна производиться только прямым платежом. Задержка более чем на 10 дней каждого причитающегося платежа или отсутствие покрытия в срок векселя, который был передан, уступлен или выставлен заказчиком, является состоянием неплатежеспособности. В таком случае мы оставляем за собой право приостановить поставку, отменить все текущие отношения, а также немедленно потребовать полной выплаты каждой задолженности и обращаться по этому поводу в суд, в исполнительном или предупредительном порядке, а также с требованием возмещения ущерба; в любом случае, по истечении 10 дней с даты причитающегося платежа, мы имеем право без предупреждения выписать переводный вексель на предьявителя с оплатой издержек. Кроме того, на просроченную задолженность начисляются проценты по неустойке по текущей процентной ставке 5 % годовых.

11 РАСПАКОВКА КОРОБОК - Продажа товара осуществляется только целыми заводскими коробками.

12 ПРАВО УДЕРЖАНИЯ ТОВАРА - товар остается нашей собственностью до момента полной оплаты поставки даже в случае, если была произведена отправка, и был выставлен счет-фактура также в случае передачи или продажи товара третьим лицам.

13 КОМПЕТЕНТНЫЙ СУД - Рассмотрение любых споров будет находиться в исключительной компетенции Суда г. Модены.

ЛОГИСТИЧЕСКИЕ УСЛУГИ

ОТМЕНА ЗАКАЗОВ – в случае отмены заказов на поставку материалов, уже поставленных на наш склад, покупатель обязан оплатить 15% облагаемой налогом их стоимости, а также минимальную фиксированную сумму в размере 20€, взимаемую в качестве оплаты транспортных расходов и пересортировки.

МИНИМАЛЬНЫЙ ЗАКАЗ – в случае ограниченных заказов, представляющих собой как «отдельные заказы», так и «дополнения» к другим заказам, облагаемая налогом стоимость которых составляет менее 100€, применяется чистая фиксированная надбавка в размере 20€.

ПОСТАВКА НЕПОЛНЫХ ПАЛЛЕТОВ – Заказы, площадью менее чем полный поддон, будут подвергаться увеличению тарифа в зафиксированном размере 1,50 евро за 1 квадратный метр.

СРОЧНЫЕ ПОСТАВКИ – при подготовке заказов в течение 24 часов, содержащих максимум 2 артикула, применяется чистая фиксированная надбавка в размере 30€.

УПАКОВКА

ЗАНЕСЕНИЕ В ДЕБЕТ СЧЕТА Специальные упаковки коллекций WIDE будут взиматься по стоимости, доступной для ознакомления в сводной таблице каждой коллекции.

ВОЗВРАТ Упаковка может быть возвращена, а ее стоимость зачена, при условии ее возврата в хорошем состоянии.

FLAVIKER-PI.SA
BRAND OF ABK GROUP INDUSTRIE CERAMICHE S.P.A.
S.S. 569 per Vignola, 226
41014 Solignano di Castelvetro (Mo) Italy
T +39 (0) 59 9752011
F +39 (0) 59 9752010
flavikerpisa.it
#flaviker



I dati riferiti ai contenuti per scatole ed ai pesi degli imballi sono aggiornate al momento della stampa del catalogo.

The data referred to the content per box and to the packing weight are update at the catalogue printing time.

Les données concernant les contenus par colis et les poids des emballage sont ajournés au moment où le catalogue est imprimé.

Die in den Tabellen enthaltenen Daten in bezug auf den Inhalt pro Karton und das Gewicht der jeweiligen Verpackung sind zum Ausgabedatums richtiggestellt worden.

La riproduzione dei colori è approssimativa
Colour reproduction approximative
Reproduction couleurs approximative
Farbdruckwiedergabe Unverbindlich



FLAVIKER

CONTEMPORARY ECO CERAMICS